

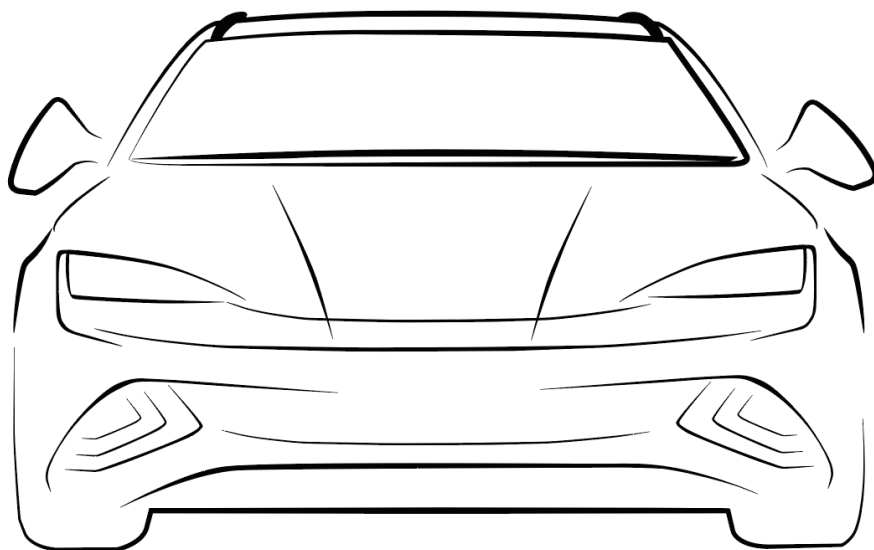

BYD SEAL

OWNER'S MANUAL



Foreword

Thank you for choosing BYD. To better use and maintain the vehicle, please read this manual carefully and keep it for future reference.

Special instructions: BYD Auto Co., Ltd. recommends that you choose genuine spare parts and use, maintain, and repair the vehicle in accordance with this manual. The use of non-genuine spare parts to replace or modify the vehicle will affect the performance of the entire vehicle, especially its safety and durability. Vehicle damage and performance issues caused thereby will not be covered by the warranty. In addition, vehicle modifications may also violate national laws and regulations and local government regulations.

Thank you for choosing BYD. Your valuable comments and suggestions are welcome. To enjoy better services, please provide your accurate contact information. If there is any change to the information, contact a BYD authorised dealer or service provider in a timely manner to update the information in the system. You are also advised to pay attention to the relevant national laws and regulations and local policies, and register the vehicle as soon as possible; otherwise vehicle registration may fail.

Descriptions marked with an asterisk (*) in this manual are applicable to some models only and attached pictures belong to one of the configurations. If there is any difference with the vehicle you purchased, the configuration of the actual vehicle shall prevail.

Pay attention to the "REMINDER", "CAUTION" and "WARNING" symbols in this manual, and follow the instructions carefully to avoid injury or damage. These symbols are defined as follows:

REMINDER

Items that must be observed to facilitate maintenance.

CAUTION

Items that must be observed to avoid damage to the vehicle.

WARNING

Items that must be observed to ensure personal safety.

 is a safety mark to indicate an operation that should not be performed or an event that should not happen.

This manual is expected to help you use the product correctly, and does not provide any description of the configuration and software version of this product. For details about the product configuration and software version, please refer to the contract (if any) related to this product, or consult the dealer who sold the product to you.

Sustainability

As a pure electric passenger vehicle, BYD SEAL is an environmentally friendly product. Please visit <https://reach.bydeurope.com> for environmental protection information about the vehicle.

It is everyone's responsibility to protect the environment. Please use this vehicle properly and dispose of any waste and cleaning materials according to the corresponding local laws and regulations.

Contact Us

If you require assistance or clarification on policies or procedures, please contact the customer service centre.

E-mail: Bydautoservice@byd.com

Call 00800-10203000 for 24/7 roadside assistance or customer service centre (Monday-Saturday 9:00-18:00).

Copyright © BYD Auto Co., Ltd. All rights reserved.

No part of this document may be reproduced or transmitted in any form or by any means without prior written consent of BYD Auto Co., Ltd.

All rights reserved

Illustration Index

Exterior	7
Dashboard	8
Interior	9
Doors	10

Safety

Seat Belts	12
Seat Belt Overview.....	12
Using Seat Belts.....	12
Airbags	15
Airbags.....	15
Driver and Front Passenger Airbags.....	16
Seat Side Airbags*.....	17
Side Curtain Airbags*.....	18
Airbag Triggering Conditions and Precautions.....	18
Child Restraint Systems	23
Child Restraint Systems.....	23
Anti-theft Alarm System	30
Anti-theft Alarm System.....	30
Data Collection and Processing	31
Data Collection and Processing.....	31

Instrument Cluster

Instrument Cluster	36
Instrument Cluster.....	36
Instrument Cluster Indicators.....	38

Controller Operation

Doors and Keys	48
Keys.....	48

Locking/Unlocking Doors.....	50
Smart Access and Start System.....	57
Child Protection Lock.....	59
Seats	60
Seats.....	60
Adjusting Front Seats.....	60
Folding Rear Seats.....	62
Rear Seat Head Supports.....	62
Steering Wheel	64
Steering Wheel.....	64
Switches	67
Light Switches.....	67
Wiper Switch.....	70
Driver's Door Switches.....	71
Passenger Side Window Switch.....	73
Odometer Switch.....	73
Mode Switches.....	73
Front Passenger Airbag Switch (PAB).....	74
Hazard Warning Light Switch.....	75
Emergency Call (E-Call)*.....	75
Interior Light Switch.....	76

Using and Driving

Charging/Discharging Instructions	78
Charging/Discharging Instructions.....	78
Charging.....	82
Discharging Device.....	89
Charge Port Anti-theft Lock.....	90
Driving Range Display.....	91
Energy Regeneration Settings.....	92
Battery	93
High-Voltage Battery.....	93
Low-Voltage Battery.....	95
Usage Precautions	96

Break-in Period.....	96
Trailer Towing.....	97
Driving Safety Precautions.....	97
Suggestions for Vehicle Use.....	98
Saving Energy and Extending Vehicle Service Life.....	99
Carrying Luggage.....	99
Wading into Water.....	100
Fire Prevention.....	101
Snow Chains.....	103
Starting and Driving.....	103
Starting the Vehicle.....	103
Remote Start.....	105
Gear Shift Controls.....	105
Electric Parking Brake (EPB).....	106
Automatic Vehicle Hold (AVH).....	108
Driving Precautions.....	109
Driver Assistance.....	111
Adaptive Cruise Control (ACC).....	111
Intelligent Cruise Control (ICC).....	115
Predictive Collision Warning (PCW) & Automatic Emergency Braking (AEB)	117
Front Cross Traffic Alert (FCTA)/ Front Cross Traffic Braking (FCTB).....	120
Traffic Sign Recognition (TSR) System.	121
Intelligent Speed Limit Control (ISLC)..	122
High Beam Assist (HMA).....	123
Lane Departure Assist (LDA).....	124
Emergency Lane Keeping Assist (ELKA).....	126
Blind Spot Detection System (BSA).....	127
Head-up Display (HUD)*	130
Tyre Pressure Monitoring.....	131
Acoustic Vehicle Alerting System (AVAS).....	132
Panoramic View System.....	133
Parking Assist System.....	135

Driving Safety Systems.....	138
Intelligence Torque Adaption Control (iTAC) System*	142
Driver Attention Warning (DAW)*	142
Child Presence Detection (CPD).....	143
0-62 mph (0-100 km/h): Full Throttle Experience.....	144
Other Main Functions.....	144
Interior Rearview Mirror.....	144
Power Side Mirrors.....	145
Wipers.....	146

In-Vehicle Devices

Infotainment System.....	148
Infotainment Touchscreen.....	148
Navigation Bar.....	149
Gestures and Responses.....	149
BYD Assistant.....	150
Bluetooth Call.....	150
File Management.....	150
A/C.....	151
A/C Panel.....	151
A/C Operation Interface.....	151
Function Definition.....	153
Vents.....	155
Air Purification System.....	156
A/C Settings.....	158
BYD App.....	158
About BYD App.....	158
Account Registration.....	158
Vehicle Condition and Control.....	159
Individual Centre and Vehicle Management.....	159
Storage.....	159
Glove Box.....	159

Cubby Box.....	160
Cup Holder.....	160
Storage Box on Interior Panel.....	161
Bill Box.....	161
Seatback Pockets.....	161
Engine Compartment Storage.....	161
In-Vehicle Devices.....	162
Sun Visor.....	162
Grab Handles.....	162
12V Auxiliary Power.....	162
USB Ports.....	163
Wireless Phone Charger.....	163

Maintenance

Maintenance Precautions.....	168
Maintenance Cycle and Items.....	168
Regular Maintenance.....	172
Regular Maintenance.....	172
Vehicle Corrosion Prevention.....	172
Paint Maintenance Tips.....	173
Exterior Cleaning.....	173
Interior Cleaning.....	175
Self-Maintenance.....	176
Self-Maintenance.....	176
Vehicle Storage.....	178
Bonnet.....	179
Cooling System.....	179
Braking System.....	180
Washer.....	180
A/C System.....	181
Wiper Blades.....	181
Tyres.....	182
Fuses.....	184

When Faults Occur

When Faults Occur.....	192
Reflective Vest.....	192
If Smart Key Battery Is Exhausted.....	192
Emergency Shutdown System.....	192
Vehicle Fire Rescue.....	193
Battery Leakage Rescue.....	193
If the Vehicle Needs Towing.....	194
If a Tyre Goes Flat.....	195
If the Low-Voltage Battery Is Exhausted.....	198
If the Vehicle Needs Support.....	199

Specifications

Data.....	202
Vehicle Parameter.....	202
Tips.....	205
Vehicle Identification.....	205
Warning Labels.....	206
Transponder Mounting.....	207
Declarations of Conformity.....	208
Smart Key.....	208
MmWave Radars.....	209
Radio Frequency.....	209

Abbreviation List

Abbreviations.....	215
---------------------------	------------

Illustration Index

Exterior

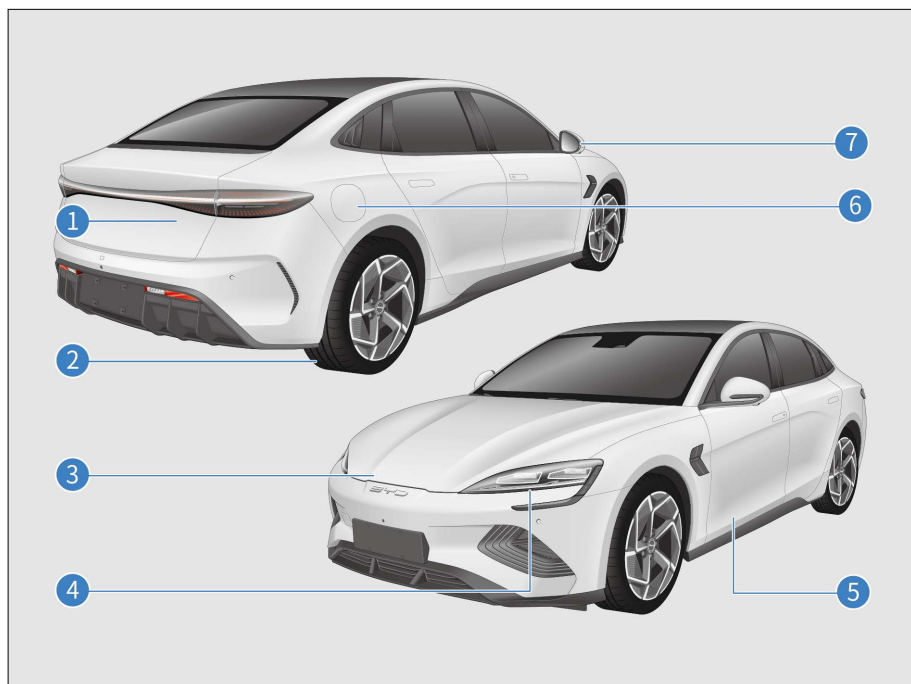

- | | | | |
|---|--|---|--|
| 1 | Boot Lid P53
Carrying Luggage P99 | 5 | Doors P51
Locking/Unlocking P51 |
| 2 | Tyre P182
Snow Chains P103
If a Tyre Goes Flat P195 | 6 | Check before Charging P82
Using Mode 2 Charging Cable* P82
Charging with AC Charging Piles* P85 |
| 3 | Bonnet P179
Coolant P179
Washer System P180
Under-Bonnet PDB Nameplate P185 | 7 | Power Side Mirrors P145
Folding Side Mirrors P145 |

Dashboard

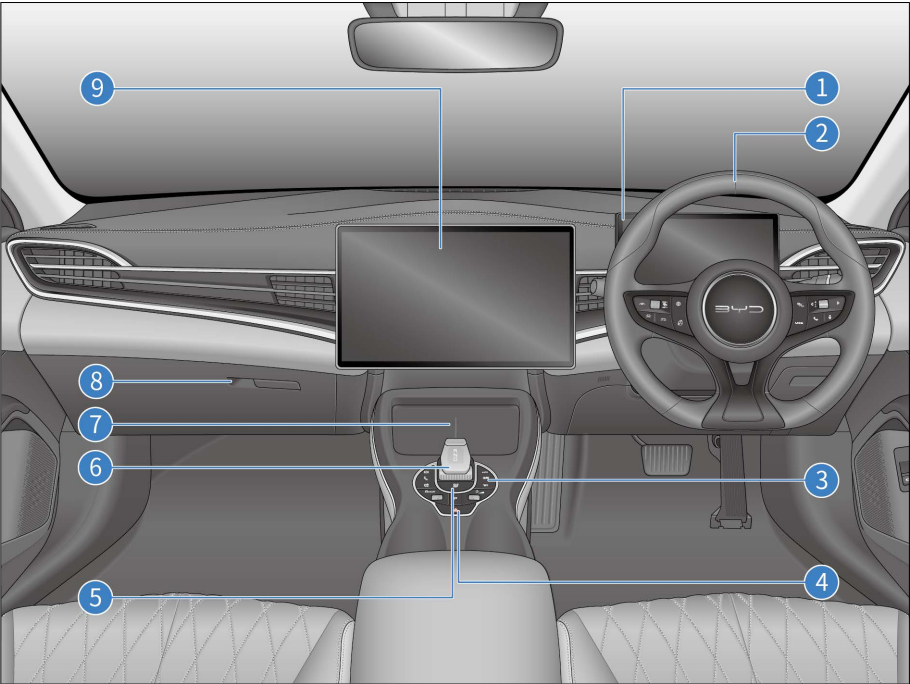

- 1 Instrument Cluster **P36**
- 2 Adjusting the Steering Wheel **P66**
Steering Wheel Switches **P64**
- 3 Front A/C Panel **P151**
- 4 Hazard Warning Light Switch **P75**
- 5 START/STOP Button **P104**
- 6 Gear Shift Controls **P105**
- 7 Wireless Phone Charging **P163**
- 8 Glove Box **P159**
- 9 Infotainment Touchscreen **P148**

Interior

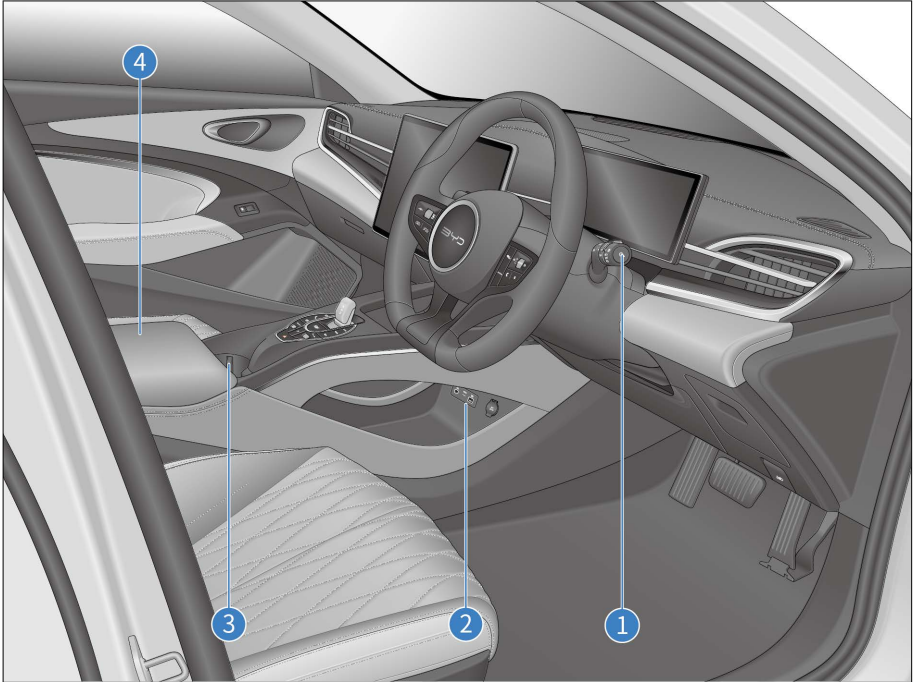

- 1 Odometer Switch **P73**
- 2 12V Auxiliary Power **P**
USB Ports **P**

- 3 Front Seat Cup Holder **P**
- 4 Centre Console Cubby **P**

Doors

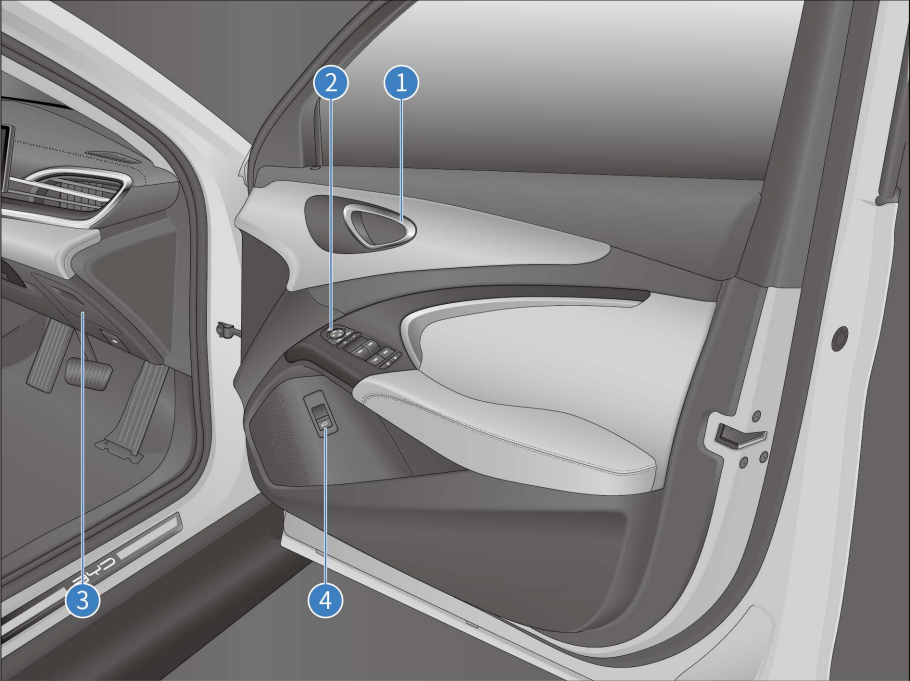

- 1 Opening with Interior Door Handle
- 2 Driver's Door Switches **P71**
- 3 Bill Box **P161**
- 4 Interior Boot Switch **P53**

01

SAFETY

Seat Belts.....	12
Airbags.....	15
Child Restraint Systems.....	23
Anti-theft Alarm System.....	30
Data Collection and Processing.....	31

Seat Belts

Seat Belt Overview

Studies have shown that proper use of seat belts can significantly reduce casualties in emergency braking, sudden steering or collisions. Please read the following information carefully and observe it strictly.

WARNING

- Always have the seat belts fastened while the vehicle is in motion.
 - Before driving, make sure all occupants are properly buckled up to prevent serious injury or death in emergency braking or in a collision.
 - The seat belts are designed primarily for adults and are not intended for children. Make sure to choose an appropriate child restraint system according to your child's age and size (see "Child Restraint Systems").
 - If a seat belt is damaged or malfunctions, immediately contact a BYD authorised dealer or service provider for confirmation and handling. Until then, do not use the corresponding seat.
- BYD has highly emphasised that all occupants should always fasten their seat belts while in the vehicle. Failure to do so increases the risk of injury in case of an accident.
 - It is recommended that children be seated in rear seats and always use seat belts and suitable child restraints. In emergency braking or

collision, unprotected children may be seriously injured and their lives may be endangered. Likewise, do not allow children to ride on someone's lap. This will render the children not adequately protected.

Emergency Locking Retractor (ELR)

- When the driver turns sharply, brakes suddenly, when there is a collision, or when the occupant leans forward too quickly, the seat belt automatically locks to effectively restrain and protect the occupant.
- When the vehicle travels smoothly, seat belts are pulled out and retracted as the occupants move slowly and smoothly, allowing the occupants to move freely.
- If the seat belt locks due to sudden retraction, pull on the seat belt webbing to create retractable slack in order to pull out the seat belt.

Pretensioner and Force Limiter Function*

When a severe front collision occurs and the triggering conditions of the pretensioner are met, the pretensioner quickly retracts part of the seat belt and locks it to improve the protection of the occupant. The force limiter limits the seat-belt restraint force to the occupant's body to a certain extent so as to avoid injury to the occupant due to an excessive restraint force.

Using Seat Belts

1. Adjust the seat position and seatback angle (see Adjusting Front Seats).
2. Adjust the position of the three-point seat belt.

- Keep the correct sitting posture and pull out the shoulder belt diagonally across the entire shoulder without contacting the neck or falling from the shoulder. Position the lap belt as low as possible around the hip.

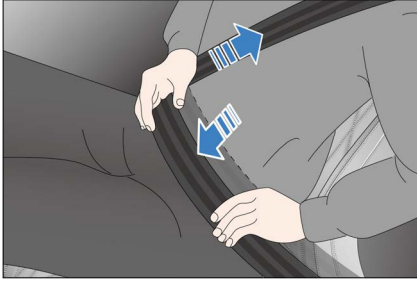

3. Insert the latch into the buckle until it clicks, and then pull it back to make sure it is firmly locked. Do not fasten the belt with any part of the strap twisted.

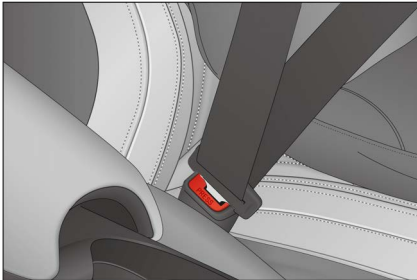

4. Adjust the height of the (front) seat belts for optimum comfort and protection.
 - ① Press the adjuster release button.
 - ② Move the adjuster up or down to the intended position. Release the button to lock the adjuster.

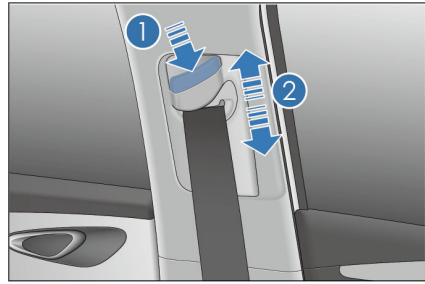

5. Pull the belt firmly to check that the adjuster is locked.

! WARNING

- The shoulder belt should cross the centre of the shoulder. The seat belt should be far from the neck and not liable to slip from the shoulder, otherwise it cannot function well in the event of emergency braking or accident, and may even cause severe injury.
- The lap belt should be positioned as low as possible around the hips to avoid serious injury due to the intense lap belt forces against the abdomen in an accident.
- The seat belt should be fitted tight to the body for better protection.

6. Unlock the seat belt.
 - Press the red unlock button on the buckle. The latch plate pops out, and the seat belt automatically retracts. If the seat belt does not retract smoothly and automatically, pull it out and check whether it is twisted.

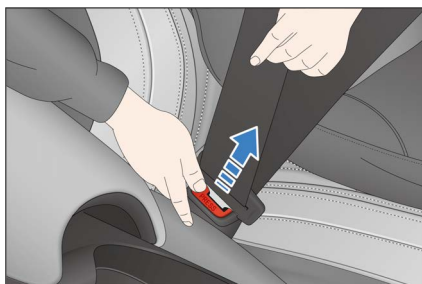

REMINDER

- The method of wearing a rear seat belt is the same as that for a front seat belt. For normal functioning of the rear seat belt, please ensure that its latch is inserted into the corresponding buckle during use. The driver should remind passengers to wear seat belts properly.
- The driver should ensure that all occupants are wearing seat belts before driving the vehicle.

WARNING

- Each seat belt should be used by one occupant only. Do not share a seat belt with another occupant, not even with a child.
- Avoid travelling with the seatback leaning too far back. The seat belt protection performs best when the seatback is upright.
- Make sure that no seat belt or its spring bolt/buckle becomes pressed by the door; otherwise the seat belt may be damaged.
- Check the seat belts regularly for cuts, wear, looseness, and other abnormalities. If any problem is found, contact a BYD authorised dealer or service provider for confirmation and

WARNING

handling. Until then, do not use the corresponding seat.

- Do not remove, disassemble or modify the seat belts without permission.
- After an accident, have the seat belts checked at a BYD authorised dealer or service provider. If the preloading function is activated, the seat belt must be replaced.
- In the event of a serious accident, even if there is no apparent damage, the seat belt should be replaced along with the seat assembly. The airbag system should also be thoroughly inspected.
- Use an approved model whenever you replace the seat belt.
- Pregnant women should also fasten their seat belt properly. Particularly, be sure to position the lap belt as low across the hip as possible to prevent serious injury.
- Do not insert foreign objects such as coins and clips into the buckle as they prevent proper connection between the latch and buckle.

Seat Belt Reminder

If the driver, front passenger or rear passenger* has not buckled up after the vehicle is started, the alarm system goes off and continues until the corresponding seat belt is properly fastened.

- Unfastened seat belt indicator
 - When any seat belt is not fastened, the unfastened seat belt indicator flashes.

- Display of unfastened belt's seat
 - The indicator for the seat with unfastened seat belt lights up.
- Seat belt reminder for the front passenger
 - If the driver or front passenger does not wear the seat belt after the vehicle is started, the seat belt indicator and the indicator associated with the corresponding seat light up. If the seat belt remains unfastened while driving, in addition to the unfastened seat belt indicator, an audible alarm is given to remind the driver and occupants.
- Seat belt reminder for rear passengers*
 - With the ignition switch on OK, if any rear-row seat belt is not fastened, the unfastened seat belt indicator and the indicator associated with the corresponding seat light up.
 - When the drive speed is above 12 mph (20 km/h) and only rear seats are loaded with occupant(s), who have not buckled up, the seat belt reminder indicator is on and an audible alarm is given.
- When the driver, the front passenger, and rear passengers* have buckled up, the seat belt reminder indicator and all indicators displayed for the corresponding seats turn off.

 **WARNING**

- In the event of abnormality or function failure, contact a BYD authorised dealer or service provider. Do not use the corresponding seat until the functions return to normal.
- When driving, make sure all occupants have their seat belts properly fastened to prevent serious injury or death in

 **WARNING**

emergency braking or in a collision.

Airbags

Airbags

- The airbag system is a part of auxiliary restraint system and also a supplement to seat belts. When the vehicle is involved in a serious collision and the airbag system meets its deployment conditions, relevant airbags will rapidly deploy and, along with seat belts, provide additional protection for heads and chests of the driver and occupants, to reduce likelihood of personal injury or even death.
- Airbags are divided into front and side types according to the type of collision. The front airbags include front passenger airbags, while the side airbags include seat side airbags and side curtain airbags.
- As an integral part of the vehicle's passive safety protection system, the airbag system does not replace seat belts and must be used in combination with seat belts to maximise protection.

Multi-collision Braking (MCB)

- In the event of an accident, the automatic braking will be activated when the driver airbag or the front passenger airbag deploys.
- Speed reduction, along with the intervention by additional driving systems (ESC and ABS), assists the vehicle to maintain stability and lane position.

- Hazard warning light and brake light would light up to warn oncoming vehicles and aid to avoid secondary collision.
- The brake is released after an accident and brake lights are turned off to support emergency rescue or recovery of the affected vehicle.
- The driver can interrupt the multi-collision braking at any time by accelerating or braking.

WARNING

- Never seat a child in the front passenger seat.
- Occupants must sit in a proper position to maximise the protection provided by seat belts and the airbag system.
- Do not disassemble or assemble airbag components without authorisation.
- If the seatbacks get wet, the side airbag system may not work properly.
- Do not use seat covers, as they restrict airbag deployment on the corresponding side in an accident.
- Do not place anything between the side airbag and the occupant.
- Do not apply excessive force to the side of seats equipped with side airbags.
- After a collision, even if the airbag module did not deploy, and the pretensioner did not lock the seat belt, the airbag computer may be encrypted in order to protect occupants from high-voltage danger. Contact a BYD authorised dealer or service provider for inspection.

Driver and Front Passenger Airbags

This vehicle is equipped with driver and front passenger airbags, when the electronic control unit (ECU) of the airbag system detects a moderate to severe front impact during driving and the triggering conditions are met, the airbags deploy.

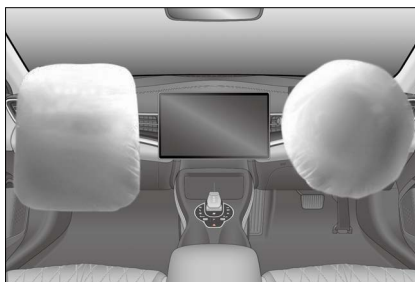

Front airbag deployment

- In moderate to severe frontal crashes, a sensor detects a sharp deceleration and sends a signal to the ECU to trigger the front airbags.
- When there is a frontal crash, the seat belt secures the occupant's lower body and torso in place. The airbag cushions and protects the occupant's head and chest.
- When the severity of the impact does not reach the airbag deployment threshold, seat belts provide the main protection while airbags assist little to the protection.
- The front airbag deflates immediately after inflation, without affecting the driver's vision and ability to operate the steering wheel or other controls.
- The airbag deploys quickly to protect the occupants when reaching the triggering condition.
- A loud noise will be heard when the airbag deploys. It will not cause injury,

but it may cause temporary tinnitus or deafness.

- A cloud of dust from the airbag surface may come off when the airbag deploys. Although such powder is non-toxic, individuals with respiratory problem might experience some temporary discomfort.
- The front passenger airbag is controlled by the passenger airbag (PAB) switch. See "PAB Switch*" for details.

Seat Side Airbags*

If the vehicle is equipped with seat side airbags (mounted on the outside of the seatback, marked with "AIRBAG" at both sides), when a moderate to severe side impact is detected during vehicle travel and the triggering conditions are met, the side airbag deploys to protect the occupant's chest to minimise the injury.

Front passenger side airbags



Rear passenger side airbags



Seat side airbags starting process

- Generally, only the airbag on the impacted side deploys in the event of a side impact.
- If the impact occurs on the passenger side, the airbag on the passenger side deploys even if there is no passenger in the seat.
- For optimal side airbag protection, occupants must have their seat belts fastened and sit upright against the seatback.

In a vehicle equipped with seat side airbags:

- Prevent the seatbacks from getting wet. If the seatbacks get wet from rain or splashes, the side airbag system may not work properly.
- Do not cover or replace seatback covers on your own. Unsuitable seatback covers may prevent airbag deployment in a collision.

Front far side airbag:

- The vehicle you purchased is equipped with a front far side airbag (installed in the inner edge of the driver's seatback and marked with "AIRBAG", as shown in the illustration).

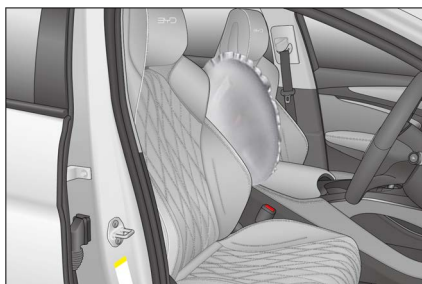

- When a moderate to severe front or side impact is detected during vehicle travel and the triggering conditions are met, the far side airbag deploys to protect the heads and shoulders of the driver and the front passenger.
- If the impact occurs on the front passenger side, the far side airbag deploys even if there is no passenger in the seat.
- For optimum protection from the far side airbag, the driver must buckle up and sit upright against the seatback.

Side Curtain Airbags*

If the vehicle is equipped with seat side airbags (mounted on the outside of the seatback, marked with "AIRBAG" at A, B and C pillars), when a moderate to severe side impact is detected during vehicle travel and the triggering conditions are met, the side airbag deploys to protect the head of the occupant in a collision.



- Generally, only the airbag on the impacted side deploys in the event of a side impact.
- For optimum curtain airbag protection, the occupant must have their seat belt fastened and sit upright against the seatback.

Airbag Triggering Conditions and Precautions

Airbag Triggering Conditions

- Airbag triggering conditions: In the event of a vehicle collision, whether an airbag will be triggered is decided by factors such as the amount of collision energy, accident type, collision angle, obstacles, and vehicle speed. The airbag system may be triggered in special collisions.
- The airbag system does not always work in any accident, and generally it will not be triggered in the event of a minor frontal collision, rear collision or rollover. In this case, the driver and passengers are protected by their properly fastened seat belts.
- Determinants of airbag system triggering: Decision is made by comparing the deceleration curve, generated in the collision and obtained by the Electronic Control Unit(ECU) and the set value. If signals, such as the deceleration curve generated and measured in the collision, are lower than the respective reference values preset in the ECU, the airbag system will not be triggered even if the vehicle may have been seriously deformed in the accident.
- The ECU of the BYD airbag system has been set up with considerations of common misuse and road conditions.

However, due to the increasing changes in causes and forms of vehicle collisions, for your safety, please strictly follow this user manual, use the vehicle correctly, and avoid its misuse. Otherwise, there is no guarantee that the airbags will achieve their expected effect.

Cases Where Airbags May Be Deployed

The vehicle's nose hits the ground when crossing a deep groove.

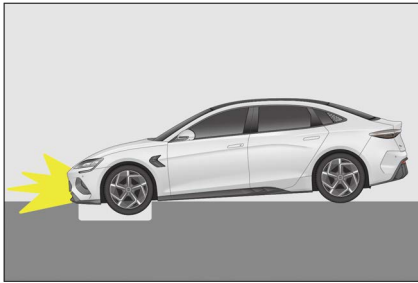

The vehicle hits a bump or curbstone.

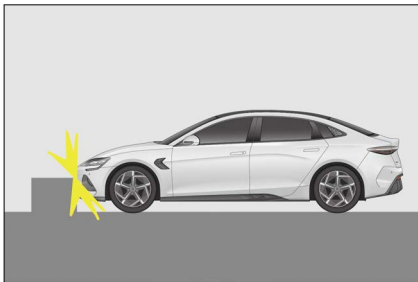

The vehicle's nose hits the ground when going down a steep slope.

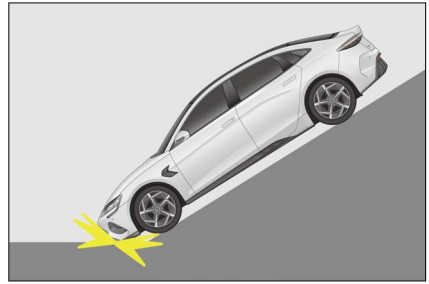

One side of the vehicle is hit by another vehicle.

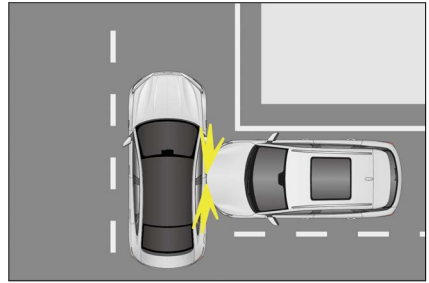

Cases When Airbags May Not Be Deployed

The vehicle hits a concrete column, tree, or other slim objects.

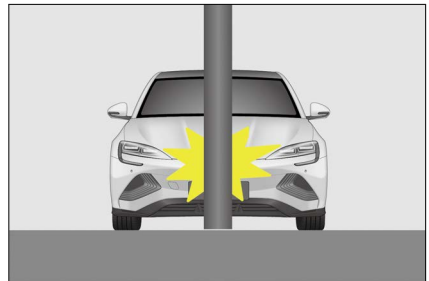

The vehicle goes under a truck or another large vehicle.

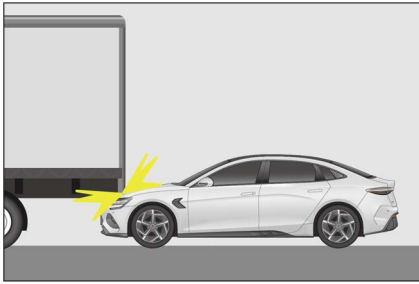

The tail of the vehicle is hit by another vehicle.



Parts other than the passenger compartment receive side impact.

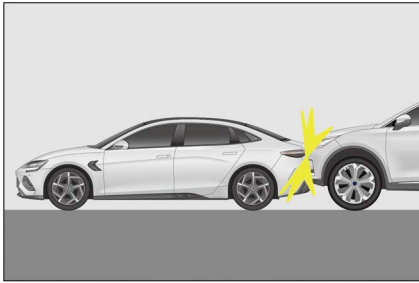

The vehicle rolls over.

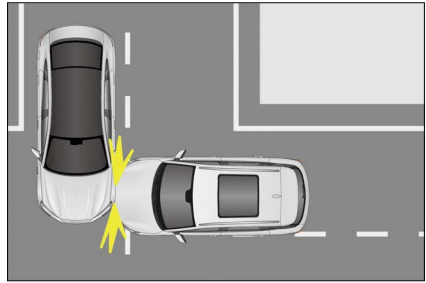

The lateral side of the vehicle is hit diagonally.

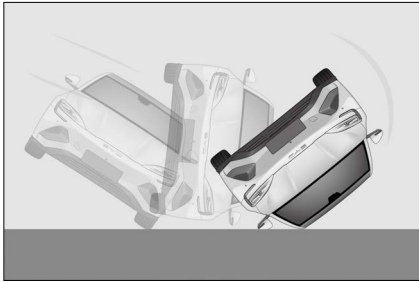

The vehicle hits a wall or a vehicle at a side other than the front side.

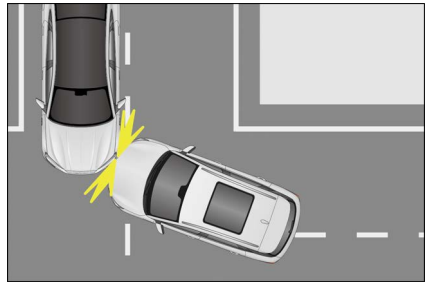

The lateral side of the vehicle hits a columnar object.

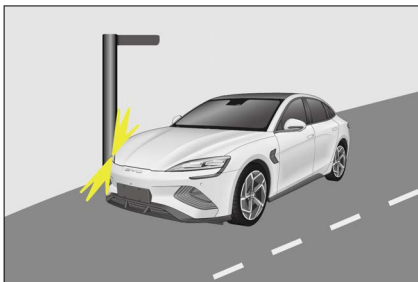

! WARNING

- Airbags are designed for specific models. Any change to suspension, tyre size, bumpers, chassis and factory-equipped devices may adversely affect the airbag system. Users must not use any parts of the airbag system on other car models; doing so may lead to failure of the airbag system.
- Drivers should maintain a distance of at least 10 in (25 cm) between their chest and the steering wheel, in order for the system to provide the most effective driver protection.
- Fasten your seat belt and sit properly while the vehicle is in motion. If the seat belt is not fastened, if the occupant is leaning forward or sitting improperly, airbag deployment can increase the risk of injury.
- Do not paste stickers, cover or decorate the hub cover of the steering wheel, the right side surface of the dashboard or the surface of A, B, and C-pillar trims. Clean these surfaces with a dry or damp cloth, without applying too much pressure.
- A child is not to be seated in the front passenger seat, nor

! WARNING

are they to ride sitting on a front passenger's lap, to prevent serious injury or even casualty caused by airbag deployment.

- No accessories, such as telephone holders, cups, ashtrays, may be installed on airbag covers or within their action range. Otherwise, airbag deployment will increase the risk of injury in an accident.
- Side airbags and side curtain airbags deploy quickly with high impact forces so that occupants must not lean against the door while the vehicle is in motion, as doing so could result in serious injury or even death.
- Do not place any other accessories or items within the action range of side curtain airbags, including the windscreen, side door glass, A-pillar trim, ceiling, B-pillar trim, C-pillar trim and auxiliary handles. When the side curtain airbag deploys, the accessories or items will be thrown by the impact force from the side air curtain airbag, or the side curtain airbag may not deploy normally, resulting in serious injury or even death.
- When transferring car ownership, make sure to pass on all of the vehicle's documents.
- Do not modify or replace seats or trims of the seats with side airbags. These changes may prevent normal deployment of side airbags, and thereby cause airbag system failure or unintended deployment of side airbags, resulting in serious injury or death.

 **WARNING**

- Do not disassemble or repair the A-pillar trim, ceiling, B-pillar trim or C-pillar trim, which contain side curtain airbags. These changes can cause failure of the airbag system or accidental deployment of curtain airbags, which may cause serious injury or even death.
- Do not change any component of the airbag system, including any corresponding label. It is recommended that any operation done to the airbags be performed by a BYD authorised dealer or service provider.
- Airbags can only provide one-time accident protection. Once the airbag is triggered or damaged, the airbag system must be replaced.
- Follow safety regulations and procedures related to the scrapping of parts of the vehicle or its airbag system.
- The airbag system has strong anti-interference and anti-disturbance resistance to electromagnetic fields around it. However, to avoid accidents, do not use the vehicle in an electromagnetic environment that violates national regulations.
- The airbag system of this vehicle is designed with full consideration of domestic common misuses and road conditions. However, in order to avoid accidents, do not have the bottom of the vehicle impacted or drive roughly in harsh road conditions.
- This vehicle's airbag system has been fully verified to seamlessly

 **WARNING**

match the vehicle's original wiring harness system. Any wiring harness modification or alteration may cause the airbags to deploy mistakenly under normal conditions or fail to deploy in the event of a collision.

It is recommended that you contact a BYD authorised dealer or service provider immediately if any of the following situations occurs.

- The airbag has deployed.
- Instrument cluster airbag warning light  lights up abnormally.
- There is a collision with the front of the vehicle (highlighted area shown), but the airbags do not deploy.

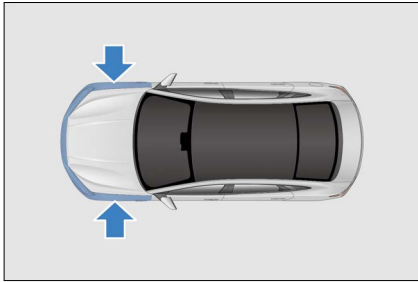

- The airbag cover (highlighted area shown) has been scratched, cracked or otherwise damaged.

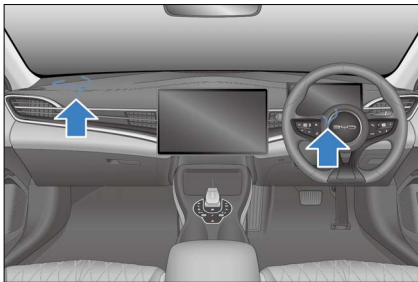

- Airbags need to be removed, disassembled, installed or repaired.
- Side airbags and curtain airbags have deployed.
- An impact to a vehicle door in an accident is not adequate to cause the airbag to deploy.

- The surface of the seat with a side airbag is scratched, cracked, or damaged similarly.
- Decorative (liner) parts at A-pillar with built-in curtain airbags, roof beam and C-pillar are scratched, cracked, or damaged similarly.

Child Restraint Systems

Child Restraint Systems

Child restraint systems provide good protection to your child in an accident. For the child's safety, please carefully read the instructions provided with the child restraint and in this manual before installing a child restraint.

WARNING

- Never carry a child on your lap in the vehicle.
- An appropriate child restraint system must be used for your child.
- Please follow the instructions provided with the child restraint system and in this manual to make sure the child restraint is properly installed in the vehicle.
- After the child restraint is dismantled from the seat, store it safely in your vehicle.
- Failure to follow the instruction provided with the child restraint and in this manual may cause injuries and even death to your child in an accident.

Children must use a suitable child restraint when travelling in the vehicle.

Children should sit comfortably and safely. Make sure that the child restraint is positioned, mounted, and used correctly.

Important considerations for selecting a child restraint system

- The child restraint system is the correct type and size for the child.
- The child restraint system is the correct type and size for the seating position.
- The child restraint must be homologated by ECE R44/ECE R129.

Passenger Airbag Switch

- The switch is located on the front passenger side of the dashboard and is accessible when the passenger's door is open.
- See **P74** for details.

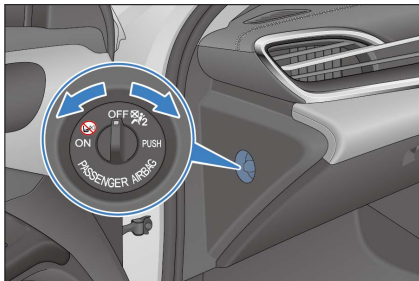

! WARNING

- Never use a rear-facing child restraint on the front passenger seat if the passenger airbag is activated.

Child Restraint System Anchorages

Front passenger seat

- The front passenger seat is equipped with ISOFIX/i-Size anchorages. The anchorage locations are identified by a marking (see illustration) located

on the seatback, directly above the associated anchorages.



- The front passenger seat is equipped with tether strap anchorages on the back.



! WARNING

- Where applicable to use a top tether strap with the child restraint system, ensure the strap is routed through the hole in the head support before attaching and tensioning the strap to the anchorage point at the base of the seat.

Rear outboard seat

- The anchorage is provided on the rear outboard seat (the label showing the anchorage is attached to the seat).

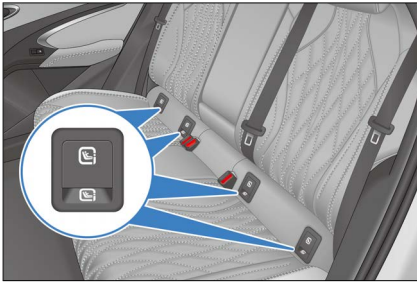

- Anchor supports (for the top tether) are provided at the rear outboard seat.

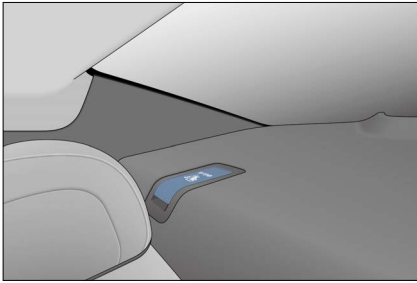

CAUTION

- Secure the top tether when installing the child restraint system.

Installing Child Restraint Systems

Precautions for installation

- ① Do not turn the anchorage lever trim cover outward.
- ② Push the anchorage lever trim cover inward in use.
- ③ Press the upper part of anchorage lever trim cover to reset after use.

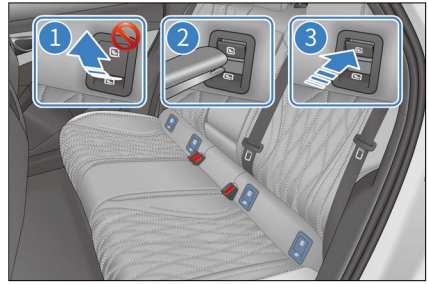

Installing child restraint systems:

1. Open the anchorage lever trim cover and install the child restraint system to the seat.



REMINDER

- The anchorage lever is located on the bevel at the rear end of the seat cushion. It can be seen when the lower part of the child restraint trim cover is pressed. After the child restraint is removed, the upper part of its cover needs to be pressed to return the cover.

WARNING

- When using the lower anchoring device, make sure that no foreign objects are around the anchoring device and that the seat belt is not stuck behind the child restraint; make sure that the

⚠ WARNING

CRS is securely fixed. Otherwise emergency parking or an accident may result in serious injury to the child or even death.

2. Open the anchor support cover.

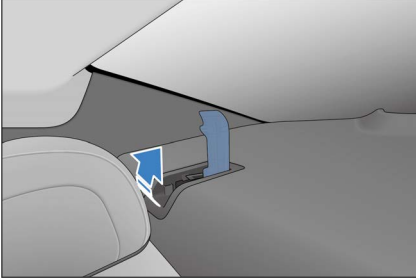

3. Fasten the snap hook to the anchor support and tighten the top tether to ensure the strap is buckled securely.

- ① Top tether
- ② Anchor support
- ③ Snap hook

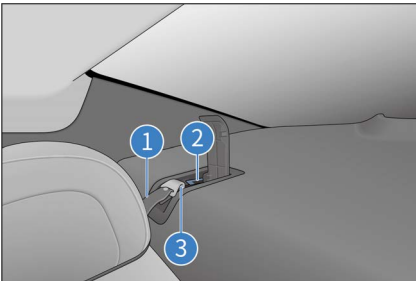

! REMINDER

- If the CRS is equipped with a top tether, secure the tether to the anchoring device.

⚠ CAUTION

- Push/Pull the child restraint in different directions to ensure it is securely installed.
- If the driver seat obstructs the correct installation of the CRS, install it on the left rear seat.
- Do not use a rear-facing child restraint system on a seat protected by front airbag (active); otherwise, in the event of an accident, the impact force applied when the front passenger airbag deploys rapidly will cause severe injury or even fatal injury to a child.



Always follow the instructions below when using a child restraint on the front passenger seat:

- Never use a rearward-facing child restraint on the front passenger seat if the passenger airbag is activated. The airbag must be activated immediately after the rearward-facing child restraint system is dismounted from the front passenger seat.
- If needed, adjust the front passenger seat backwards so that there is no contact between the child and vehicle interior.
- If needed, the front passenger seatback and seating height can be adjusted so that it has secure contact with the child restraint system.

- For child restraint systems with the guide fitting of belt attached to the child seat headrest, ensure that the guide fitting is positioned forward or in line with the seat belt upper anchorage on the vehicle's B-pillar.
- When a forward-facing child restraint system is used on the front passenger seat, ensure that the seat is positioned fully rearward away from the active airbag.
- Ensure that the seat belt passes through the guide fitting without kinking and is not bent over the edge of the guide fitting.

Always follow the instructions below when using a child restraint on a rear seat:

- If there is no front passenger, the front passenger seat can be adjusted to make sure there is enough space between the front seat and rear child seat.
- The head restraint can be adjusted or even removed to ensure that the vehicle seatback can safely support the child restraint system.
- When a child restraint is without seatback, never remove the head restraint from the vehicle and adjust it to the locking position.

- When the top tether is used on a rear outboard seat, route it at the outside of each head post.
- For more installation instructions, please read the instructions provided with your child restraint system.

Details on child restraint system installation:

- ① Driver seat
- ② Front passenger seat
- ③ Rear left seat
- ④ Rear centre seat
- ⑤ Rear right seat

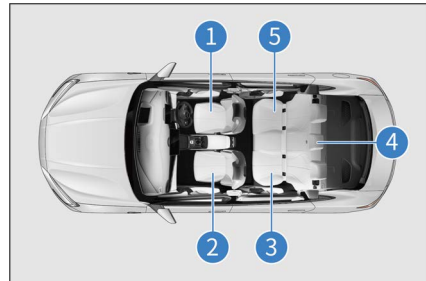

ISOFIX or i-Size CRS installing options in the vehicle:

Seating Position						
	1	2		3 ^{b)}	4 ^{b)}	5 ^{b)}
		Front Passenger Airbag Activated ^{a)}	Front Passenger Airbag Deactivate ^{d a)}			
Seating position suitable for	×	Yes Forward-facing only	Yes	Yes	Yes	Yes

Seating Position						
2						
1	Front Passenger Airbag Activated ^{a)}	Front Passenger Airbag Deactivate ^{d a)}	3 ^{b)}	4 ^{b)}	5 ^{b)}	
universal belted (Yes/No)						
i-Size seating position (Yes/No)	×	Yes Forward-facing only	Yes	Yes	No	Yes
Seating position suitable for lateral fixture (L1/L2/No)	×	No	No	No	No	No
Largest suitable rearward-facing fixture (R1/R2X/R2/R3/No)	×	No	R1/R2X/R2/R3	R1/R2X/R2/R3	No	R1/R2X/R2/R3
Largest suitable forward-facing fixture (F2X/F2/F3/No)	×	F2X/F2/F3	F2X/F2/F3	F2X/F2/F3	No	F2X/F2/F3
Largest suitable booster fixture (B2/B3/No)	×	B2/B3	B2/B3	B2/B3	No	B2/B3

Seating Position					
2					
1	Front Passenger Airbag Activated <small>a)</small>	Front Passenger Airbag Deactivate <small>d a)</small>	3 ^{b)}	4 ^{b)}	5 ^{b)}

a) If needed, the seat can be adjusted in forward or backward, and the seatback angle can be adjusted.

b) If needed, the headrest can be adjusted or even removed. The front seats can be adjusted to ensure the child is not in contact with them.

×: seat position not suitable for installing a child restraint of this weight group.

• Recommended child restraint systems:
Grouping of child stature according to standard of ECE R129

Recommended child restraint systems

Choose a suitable child restraint system for your child's age and stature.

Child Stature	Manufacturer	Child Restraint Systems	Comment
16-33 in (40-83 cm)	Maxi-Cosi	Pebble 360	Belted
30-41 in (76-105 cm)	Britax Römer	Trifix 2 i-Size	ISOFIX and belted
39-59 in (100-150 cm)	Britax Römer	Kidfix i-Size ^{a)}	ISOFIX and belted

^{a)}: Be sure to attach the seat belt through SecureGuard and XP-PAD.

Grouping of child weight according to ECE R44 standard

Child Weight	Manufacturer	Child Restraint Systems	Comment
49-79 lb (22-36 kg)	Graco	Booster Basic	Belted

① 16-33 in (40-83 cm)

④ 49-79 lb (22-36 kg)

② 30-41 in (76-105 cm)

③ 39-59 in (100-150 cm)



Anti-theft Alarm System

Anti-theft Alarm System

When armed, the system sounds an alarm and triggers turn signal flash when any door is opened.

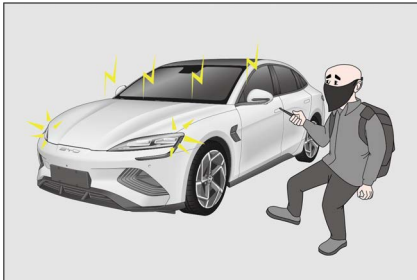

Arming the system

1. Switch the ignition off.
2. All occupants get off the vehicle.
3. Lock all doors. This makes the anti-theft indicator steady on. The anti-theft alarm system will arm automatically after 10 seconds, and the anti-theft indicator will then begin to flash.
4. You can leave the vehicle after confirming that the indicator begins to flash. Since unlocking the door from inside the vehicle will activate the

system, never let anyone stay in the vehicle with the system enabled.

Triggering the alarm

- The system will raise an alarm in any of the following situations:
 - Any door, boot, or bonnet is opened without using the keyless access function of the smart key.

Disarming the system

- Anti-theft alarm can be stopped by:
 - Unlocking the door with a valid smart key/NFC card.
 - Using the microswitch to unlock the door by carrying a valid smart key.
 - Opening the boot remotely with a valid smart key.
 - Starting the vehicle remotely with a valid smart key.
 - Pressing the START/STOP button inside the vehicle while carrying a valid smart key.

WARNING

- Do not modify the anti-theft system by means of alteration or addition. Otherwise, the system may fail.

Anti-theft Indicator

With the vehicle power OFF and four doors locked, the anti-theft indicator stays on for about 10s after the anti-theft mode is activated.

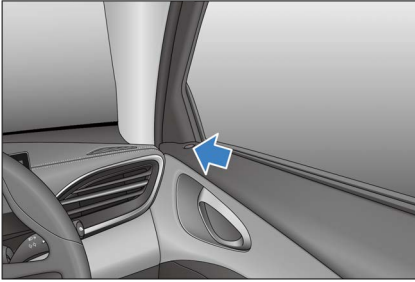

Data Collection and Processing

Data Collection and Processing

- This section provides you with some important information on how personal data is collected and processed when you use a BYD vehicle.
- For a more detailed overview on data processing, data protection and data subject rights, please read the current version of the privacy policy for the vehicle available at the infotainment system (**Vehicle Settings** → **System Settings** → **More** → **Privacy Policy**).
- This vehicle is equipped with an event data recording (EDR) system. EDR mainly records data in the event of a crash or near-crash (for example, airbag deployment or hitting on a roadside obstacle) to help comprehend the vehicle system operation, such as:
 - Vehicle velocity
 - Tyre pressure condition
 - Adaptive cruise control (ACC) system status
 - Whether the seat belt is fastened
- The vehicle records EDR data only when there is a crash or when a near-crash event reaches a certain extent. The EDR does not record any data during the normal driving of the vehicle.
- The data recorded by the EDR system provides an understanding of the state of the vehicle's safety-related systems when an accident occurs, so that relevant parties can analyse the accident.
- The EDR data needs to be accessed and read by special equipment. BYD discloses your personal data to third parties only if this is legally permissible or you have consented to it. In addition to the vehicle manufacturer, third-party agencies with professional equipment (such as government agencies) can also read the EDR data if they have access to the vehicle EDR and equipment (for example, they can read the data of SRS control unit to clarify the accident).

Vehicle Data Processing

- Data is collected when the vehicle is used, such as data collected or transmitted by vehicle sensors or control units, which is necessary for the safe functioning of your vehicle.
- In some cases, the data is used to support driving (driver assistance systems) or to enable a specific comfort or infotainment function.
- Personal data that is collected and processed mainly include in-vehicle data, remote-services-related data, and other data, as further specified below.

In-vehicle data

Operation data

- When the vehicle is used, various vehicle status data (e.g., speed, battery level, and braking system) or environment (e.g., distance sensors and temperature) data is collected and processed.
- This data is not usually stored, but there are control units, sensors or other components installed in the vehicle that record such data, for example, to record maintenance requirements, error messages, or other information.
- The in-vehicle data will only be stored in the equipment in the vehicle but can be read out via the legally required OBD ("On Board Diagnostics") interface, for example, by BYD authorised dealer or service provider or other third parties.
- In case this access takes place during vehicle maintenance, the information can also be transmitted to BYD engineers for quality assurance, product defect reports, or customer claim verification.

Remote-services-related data

Remote monitoring services

- These include remote monitoring services such as remote diagnosis and over-the-air (OTA) updates and upgrades for security and safety purposes (subject to owner's approval).
- These monitoring services serve the following purposes: service provision (remote support/diagnostics), product development, and security/public safety.
- Depending on the country and setup, various vehicle information can be transmitted to BYD's data centre in corresponding market for the above purposes, including vehicle location information, vehicle status, such as

energy consumption, vehicle speed, gear position, power mode, ESC status, steering system status, battery status, powertrain status, and overall vehicle performance status.

Other

Infotainment system

- Depending on vehicle configuration, data can be added to the infotainment system by the users themselves, such as media data for playing video on the infotainment system, address data for use in the navigation system, or data for use in online services.
- Depending on vehicle configuration, individual settings in and on the vehicle can also be entered.
- Data stored in the vehicle can be deleted at any time.
- BYD has no control over data transferred to third parties (from the use of third party content, in particular as part of online services).

Integration of mobile devices

- Depending on vehicle configurations, mobile devices can be connected and controlled through the vehicle's infotainment system.
- It may be necessary that the device's screen or audio is displayed/played through the infotainment system or transmitted to it.
- Additional data like positioning or vehicle information can be transmitted through applications for use in certain navigation systems, communication, or other third-party services.
- The specific type of data processing depends on the respective function and is controlled by the user or third parties such as the provider of the devices or corresponding services.

Internet access and connected services

- Depending on vehicle configurations, the Internet can be accessed for certain functions or BYD services through the vehicle's infotainment system network devices.
- BYD is not liable for any such services provided by any other party.
- In such cases, please obtain information about the use of data from the provider of the respective online service.



Camera image recording/surrounding area monitoring

- Your vehicle is equipped with a number of cameras/sensors.
- The reason for this is that some vehicle functionalities require the vehicle's path to be detected and assessed which is done by cameras that detect objects in the vehicle's surroundings (e.g., obstacles).
- The images are transmitted to the respective control module for further analytics required to operate the systems.
- Some images are just processed on a volatile basis (RAM), others may be stored, depending on vehicle equipment.
- The vehicle may be equipped with an outward-facing camera (OFC) that can be used to take footage of the surrounding (dashcam).
- The vehicle may also be equipped with an inward-facing camera (IFC), which can be used to take footage inside the vehicle.
- Both OFC and IFC footage will be stored.
- Please be aware of corresponding laws before turning on your OFC or IFC (for instance, in some countries consent is required for the use of IFC, and

in others OFC is strictly restricted to dashcam purposes).

- For more camera details, see section "Panoramic View System" in this manual.

Permanent Vehicle Transfer to Third Parties and Offline Mode

- In case of a permanent vehicle transfer, i.e., second hand vehicle, or vehicle transfer by a third party for permanent use, it must be noted that any personalisation/user settings made via the infotainment system (e.g. address list, navigation system, etc.) may be accessed by the new owner.
- You can also restrict your vehicle's communication with the BYD data server and the processing of vehicle-related and personal data by setting the vehicle to offline mode.
- On the infotainment touchscreen, tap  to turn Wi-Fi off.
- This can also be done by tapping  → System Settings → Internet → WLAN → Off.

Disclosure of Personal Data to Authorities

- BYD discloses your personal data to third parties only if this is legally permissible or you have consented to it.
- However, subject to applicable laws, government agencies may be authorised to read out data from vehicles (e.g. data can be read from the airbag control unit to clarify an accident).
- If required by law, BYD may also be obliged to disclose data upon request to governmental authorities in your

country, e.g. in the investigation of a criminal offence.

Your Data Protection Rights

- BYD has staunch respect for its customer's privacy, and strictly complies with all data protection laws, in particular the General Data Protection Regulation (GDPR) and applicable local laws.
- According to these laws, owners have specific rights when their personal data is processed:
 - Data subjects have the right of information and access, to rectification, erasure of personal data ("right to be forgotten") and the right to object to the processing of personal data or to restrict it (or to withdraw consent given earlier, as well as the right to data portability).
- These rights may be limited in some cases. For example, if we can show that we have a legal obligation to process your data, or if providing the information to you would disclose personal data about another person, or if we are legally prevented from disclosing that information.
- In some cases, this may mean that we can retain the data even if you withdraw your consent.
- For more information on data processing, data protection, and any rights you may have, please visit the latest version of the Privacy Policy available at the infotainment system (**Vehicle Settings** → **System Settings** → **More** → **Privacy Policy**).

02

INSTRUMENT CLUSTER

Instrument Cluster.....36

Instrument Cluster

Instrument Cluster

LCD Instrument Cluster

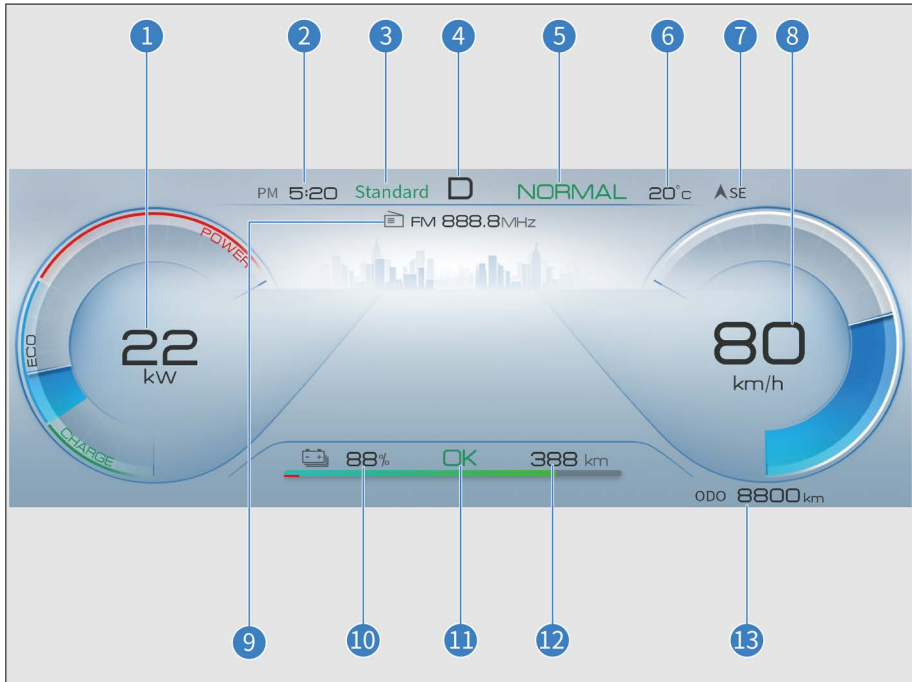

- | | | | |
|---|--------------------------------|----|---|
| 1 | Power meter | 8 | Speedometer |
| 2 | Time | 9 | Media (radio, music and call) |
| 3 | Regenerative braking intensity | 10 | State of charge (SOC) |
| 4 | Gear status | 11 | OK button |
| 5 | Dynamic mode | 12 | Remaining driving range |
| 6 | Outside temperature | 13 | Total mileage (Mileage 1 and Mileage 2) |
| 7 | Direction | | |

CAUTION

- For BYD SEAL, the instrument cluster is available in two themes, namely, classic and minimalist styles. Each theme has “Dark” and “Light” modes dedicated for day and nighttime respectively.

Instrument cluster view in simple mode

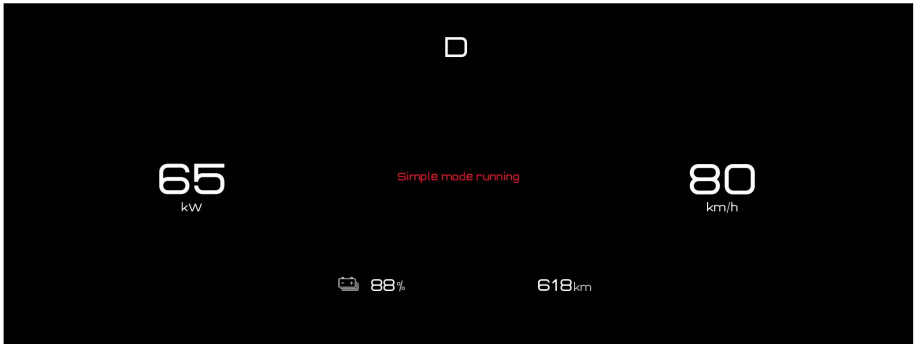

CAUTION

























- During occasional communication delays in the instrument cluster system, for safe driving, the instrument cluster may automatically switch to simple mode. In this mode, the cluster continues to display driving related information normally, without affecting normal vehicle travel. After the system becomes normal, the cluster may automatically exit the simple mode. If it does not, try the following actions to switch back to normal mode:
 1. Press and hold the scroll button on auxiliary dashboard for three seconds to restart the instrument cluster information display system.

























CAUTION

2. While vehicle safety is ensured, operate the vehicle power switch to turn off the vehicle and then switch back to the OK position.
- If the instrument cluster remains in simple mode after those actions have been taken, promptly contact a BYD authorised dealer or service provider for inspection.
 - The image of the instrument cluster view is for reference only and is subject to actual factory configuration.

Instrument Cluster Indicators

Indicators/Warning Lights

	Turn signal indicator		Position light indicator
	High beam indicator		HMA indicator*
	OK indicator		Discharge indicator
	ICC indicator		Hill descend control indicator
	AVH indicator		Exterior light switch indicator
	Economic mode indicator		Sport mode indicator
	Normal mode indicator		AEB indicator
	ACC speed indicator		ACC warning light
	Snow mode indicator		AVAS OFF indicator
	High-voltage battery low SOC warning light		AEB warning light
	Driver attention warning light*		Rear fog light indicator
	Tyre pressure fault warning light		Smart key warning light

	ESC OFF warning light		Main alarm indicator
	ESC fault warning light		Headlight fault warning light
	ABS fault warning light		Driving power limit warning light
	BSD indicator*		Reversing radar error warning
	CPD indicator/warning light*		Steering system fault warning light
	PCW warning light (red)		High-voltage battery overheating warning light
	Motor overheating warning light		Motor coolant overheating indicator
	Powertrain fault warning light		Parking system fault warning light
	Seat belt reminder indicator		Airbag fault warning light
	EPB indicator		Low-voltage power system fault warning light
	TSR indicator		High-voltage battery fault warning light
	High-voltage battery charging connection indicator		Zero position indicator

Indicators/Warning Lights Description



Smart key warning light

- If the key is not in the vehicle when you press the START/STOP button, this warning light comes on for a few seconds, a beep sounds, and the message "No key detected, please

confirm if the key is in the vehicle" is displayed on the instrument cluster.

- If you press the START/STOP button while an electronic smart key matching the model is in the vehicle, this warning light does not light up. The vehicle can now be powered on.
- If the warning light flashes after you press the START/STOP button, it indicates low battery of the key.
- If the key is not in the vehicle, the instrument cluster prompts "No key detected, please confirm if the key is in the vehicle".



ABS fault warning light

- This warning light comes on when the ignition is on. If the anti-lock braking system (ABS) is working properly, the light goes out in a few seconds. Thereafter, if the system fails, the light lights up again until the fault is cleared.
- When the ABS fault warning light is on (with the parking system fault warning light off), the braking system continues to operate whereas the ABS does not.
- When the ABS fault warning light is on (with the parking system fault warning light off), since the ABS system does not operate, the wheels will be locked in case of emergency braking or braking on a slippery road.
- If any of the following cases occurs, it means there is a fault in components monitored by the warning light system. In that case, contact a BYD authorised dealer or service provider for vehicle inspection as soon as possible.
 - This warning light does not come on or is steady on when the ignition is on.
 - This warning light turns on while driving.



REMINDER

- A warning light that lights up briefly during operation does not indicate a problem.
- If the parking brake system warning light and the ABS warning lights light on at the same time, stop the vehicle safely right away and contact a BYD authorised dealer or service provider. In this case, if brakes are applied, the ABS will not work and the vehicle will become extremely unstable.
- If both the ABS indicator and braking system warning lights go on after the Electronic Parking Brake (EPB) is released, it indicates that the electronic brake-force distribution (EBD) system of the front and rear tyres has also failed.



Tyre pressure fault warning light

- This warning light comes on when the ignition is on. It turns off in a few seconds if the tyre pressure monitoring system is working properly. If the system fails, this warning light turns on again.
- When the tyre pressure fault warning light comes on or flashes, the message "Please check TPMS" is displayed on the instrument cluster, and the tyre pressure is displayed as "----", it indicates that the tyre pressure system is faulty.
- When the tyre pressure value displays "Abnormal Signal", it indicates that the tyre pressure signal at the location of the vehicle may be disturbed or the tyre pressure monitoring module is damaged.
- When the tyre pressure fault warning light flashes rapidly, and one or more

values turn red on the tyre pressure screen on the instrument cluster, the corresponding tyre is leaking rapidly.

- When the tyre pressure fault warning light is solid on and one or more values turn yellow on the tyre pressure screen on the instrument cluster, the corresponding tyre is in under-pressure condition. When the temperature value of one or more tyres turns yellow, it indicates that the tyre temperature is too high.

In the event of any of the situations above, it is recommended to contact a BYD authorised dealer or service provider for inspection as soon as possible.



ESC fault warning light

- This warning light comes on when the ignition is on. If Electronic Stability Controller(ESC) functions properly, the light goes out in a few seconds. If the system fails, this warning light turns on again until the system fault is cleared.
- If the ESC warning light flashes temporarily while the vehicle is in motion, it indicates the ESC system is working.
- When the ESC warning light turns on (with the ABS fault warning light and the parking system fault warning light off), the ESC fails, but the ABS and the braking system continue to operate normally.
- When the ESC warning light turns on (with the ABS fault warning light and the parking system fault warning light off), the ESC system does not work. This means the vehicle is extremely unstable at sharp turns or when the driver steers away from obstacles ahead.
- If any of the following cases occurs, it means there is a fault in components

monitored by the warning light system. In that case, contact a BYD authorised dealer or service provider for vehicle inspection as soon as possible.

- This warning light remains off (self-check not performed) after the vehicle is powered on.
- This warning light is steady on while driving.

REMINDER

- A warning light that lights up briefly during operation does not indicate a problem.
- If the ESC warning light remains on while the warning lights for the ABS and the braking system are on, immediately stop the vehicle in a safe place and contact a BYD authorised dealer or service provider. This is because braking at this time can render the vehicle extremely unstable, and the anti-lock braking system does not work at all.



ESC OFF warning light

- When the ESC OFF switch is pressed, this warning light should remain steady on and the ESC system will not operate. When the ESC OFF switch is pressed again, this warning light should turn off and the ESC system resumes its normal operation.

REMINDER

- While the ESC OFF warning light is on, the driver must stay alert and keep driving at a lower speed when making a sharp turn and when avoiding an obstacle which appears suddenly, because

REMINDER

ESC system is malfunctioned at this time and braking will cause instability.



Driving power limit warning light

- When the power of the vehicle is limited, this warning light comes on. In this case, contact a BYD authorised dealer or service provider in time.



Headlight fault warning light

- When the warning light is yellow, it indicates the headlight is faulty, and it is recommended to bring the vehicle to a BYD authorised dealer or service provider for inspection.



Blind spot detection (BSD) indicator

- When this indicator is on, it is recommended to bring the vehicle to a BYD authorised dealer or service provider for inspection.



Main alarm indicator

- If this indicator goes on, check the fault prompt or warning on the instrument cluster.



Driver attention warning (DAW) light

- Driver attention warning (DAW) system evaluates the driver's degree of fatigue by the vehicle operation status. The driver would be reminded according to the evaluation results to ensure driving safety.



CPD indicator/warning light*

- CPD indicator*: If child presence detection (CPD) is turned off, the indicator is solid on, and the OFF reminder lasts for five seconds. Tap **ON** or **Delay**. The indicator turns off and CPD is enabled.
- CPD warning light*: If the CPD fault reminder lasts for five seconds and the indicator is solid on, it indicates that the CPD system fails. It is recommended to bring the vehicle to a BYD authorised dealer or service provider for inspection.



Seat belt reminder indicator

- With the ignition switched on, if any passenger on the front seats or rear seats* has not buckled up, the seat belt reminder lights up. It remains on until the seat belt is fastened.



Airbag fault warning light

- With the ignition is on, this warning light turns on and then goes off in a few seconds if the airbag system is working properly. This warning light is used to monitor the airbag ECU, collision sensors, inflation device, warning lights, connections, and power supply.
- If any of the following cases occurs, it means there is a fault in components monitored by the warning light system. In that case, contact a BYD authorised dealer or service provider for vehicle inspection as soon as possible.
 - When the ignition is switched on, this warning light remains off or is solid on after the ignition is switched on.

- This warning light turns on while driving.

Parking system fault warning light

- When the brake fluid level is low and the braking system is faulty, this warning light lights up. If any of the following conditions occurs, immediately park the vehicle in a safe place. It is recommended to contact a BYD authorised dealer or service provider.
- This warning light comes on when the ignition is switched on and the brake fluid level is low.

REMINDER

- When the brake fluid level is low, park the vehicle because it is dangerous to continue driving.
- This warning light is solid on although after starting the vehicle, the brake fluid level and EPB system operation are normal (the EPB is engaged and released normally, and the message "Please check the EPB" is not displayed).
- Both the parking brake fault warning light and the ABS fault warning light are on.

REMINDER

- A warning light that lights up briefly during operation does not indicate a problem.

Steering system fault warning light

- When the steering system is faulty, this warning light is steady on. It is recommended to bring the vehicle to

a BYD authorised dealer or service provider for inspection.

REMINDER

- The steering system features an electric motor to reduce the force required to turn the steering wheel.
- When turning the steering wheel, a hum may be heard from the running motor.
- Do not turn the steering wheel to its limit position for more than five seconds, otherwise the temperature protection will be activated and the steering system will be damaged or steering will become heavy.
- If you have turned the steering wheel frequently with the vehicle staying put for a long time, the steering wheel may become difficult to turn even if the warning light does not turn on. This is not a fault.
- To prevent steering system overheating, the power assist effect will be reduced if the steering wheel has been frequently turned with the vehicle staying put for a long time. As a result, the steering wheel become difficult to turn. In this case, reduce steering frequency or power off the vehicle. The system will recover within 10 minutes.

WARNING

- If the steering system warning light goes on, immediately park the vehicle safely, and contact a BYD authorised dealer or service provider.

Zero position indicator light

- If the vehicle loses power due to abnormal operations such as connecting/disconnecting low-voltage batteries or fuses, when the power supply of the vehicle is restored, the zero position indicator light on the instrument cluster lights up..
- In this case, it is necessary to perform zero self-learning operation of the steering wheel angle, namely: Turn the steering wheel slowly and fully to the left and right respectively, and release it in two to five seconds. Then shut down the engine and wait for over 10 seconds. Restart the vehicle, the indicator light disappears, the learning is over.



Low-voltage power system fault warning light

- If this warning light turns on while driving, it indicates that there is a problem with the DC system or the low-voltage power system. Turn off devices such as the A/C, fan, and radio, and pull over the vehicle immediately if it is safe to do so. It is recommended to contact a BYD authorised dealer or service provider for rescue as soon as possible.



Powertrain fault warning light

- If the powertrain fails, this warning light turns on.
- If any of the following cases occurs, it means there is a fault in components monitored by the warning light system. In that case, contact a BYD authorised dealer or service provider for vehicle inspection as soon as possible.
 - This warning light is steady on when the ignition is switched on.
 - This warning light turns on while driving.



CAUTION

- Try not to drive the vehicle when the warning light is on. Contact a BYD authorised dealer or service provider to check the problem as soon as possible.



High-voltage battery overheating warning light

- If this indicator is on, it indicates that the high-voltage battery temperature is too high and the vehicle must be stopped to cool down. When the warning light flashes, it is recommended to immediately stop the vehicle safely and leave the vehicle as soon as possible.
- The high-voltage battery may overheat under the following operating conditions:
 - Driving up a slope for a long time in hot weather.
 - Long period of stop-and-go traffic conditions, frequent rapid acceleration, frequent hard braking, or vehicle running for a long time without pause.



High-voltage battery fault warning light

- This warning light comes on when the ignition has just been switched on. If the high-voltage battery system is working properly, this warning light will turn off in a few seconds. Thereafter, if the system fails, this light will light up again. It is recommended to contact a BYD authorised dealer or service provider for inspection as soon as possible.
- If any of the following cases occurs, it means that there are faults in the components monitored by the

warning light system. In such case, it is recommended to contact a BYD authorised dealer or service provider for vehicle inspection as soon as possible.

- This warning light is steady on when the ignition is on.
- This warning light is steady on or occasionally turns on while driving.



PCW warning light (red)

- When this warning light is on or flashes, pay attention to the distance from the vehicle ahead, and do not get too close to it to prevent potential collision.



Motor coolant overheating

indicator

- If this indicator is solid on, it indicates that the motor coolant temperature is too high. Park the vehicle in a safe area until this indicator goes out.







Traffic sign recognition (TSR) indicator*

- When this indicator lights up, it means that the vehicle system has recognised the speed limit value on current road section.

Other Instrument Cluster Fault Prompts

The instrument cluster may display the following fault prompts. Handle them as recommended:

Symbol	Error Message	Response
	Please check the OBC system	The on-board charging system is faulty. In this case, check the charging connection, and reconnect the charging equipment. If the fault persists, contact a BYD authorised dealer or service provider.
	Please check the data network of the vehicle.	The vehicle may be disconnected from the data network. In this case, park the vehicle immediately at a safe place, and contact a BYD authorised dealer or service provider.
	EV power limited	The EV function is limited. Contact a BYD authorised dealer or service provider immediately.
	Please check the headlight	The headlight is faulty. In this case, contact a BYD authorised dealer or service provider.
	ADAS is limited*	The predictive collision warning and automatic emergency braking systems are faulty. In this case, park the vehicle, and contact a BYD authorised dealer or service provider.

Symbol	Error Message	Response
	ADAS is limited*	The blind spot assist system is faulty. In this case, park the vehicle, and contact a BYD authorised dealer or service provider.
	ADAS is limited*	The lane departure assist system is faulty. In this case, park the vehicle, and contact a BYD authorised dealer or service provider.
	Intelligent-camera is not available due to poor condition*	The intelligent camera is unusable. Check whether the visual field of the camera on the front windscreen is blocked by foreign objects or is foggy. If not, contact a BYD authorised dealer or service provider.
	Please check the gear*	The shifter controller is faulty. In this case, park the vehicle immediately, and contact a BYD authorised dealer or service provider.

03

CONTROLLER OPERATION

Doors and Keys.....	48
Seats.....	60
Steering Wheel.....	64
Switches.....	67

Doors and Keys

Keys

The vehicle is equipped with keys, including the electronic smart key, NFC card* and mechanical key (installed in the electronic smart key) to enable functions such as unlocking/locking doors and starting the vehicles.

Electronic Smart Key

Lock or unlock all doors by pressing the driver's door microswitch while carrying the electronic smart key. Buttons on the key help you lock or unlock doors, open the boot, and start the vehicle remotely.

- ① Lock button
- ② Unlock button
- ③ Boot release button
- ④ Start/Stop button
- ⑤ Indicator
- ⑥ Mechanical key

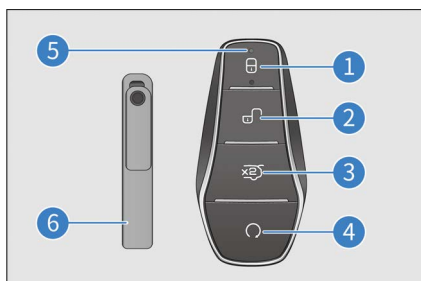

WARNING



Button battery safety alert:

- The button (coin) battery in the smart key is hazardous and both

WARNING

new and used batteries are to be kept away from children at all times.

- If swallowed or placed inside any part of the body, a lithium button battery can cause severe or fatal injuries in two hours or less.
- Medical attention should be sought immediately if it is suspected the button battery has been swallowed or placed inside any part of the body.

CAUTION

- The electronic smart key is an electronic component. The following instructions should be observed to prevent damage to the electronic smart key.
 - Do not place the smart key in a position exposed to high temperature, such as on the dashboard.
 - Do not tamper with the smart key.
 - Do not hit other objects with the smart key or drop it.
 - Do not immerse the key in water or clean it in the ultrasonic scrubber.
 - Do not place smart keys with devices that emit electromagnetic waves, such as the mobile phone.
 - Do not attach any objects (such as a metal seal) which cut off electromagnetic wave signals when using the card.
- You can register a spare key for the same car. In this case,

 **CAUTION**

contact a BYD authorised dealer or service provider immediately.

- If the electronic smart key cannot operate the door within the normal distance, or the key indicator light is dim or off:
 - Check for nearby radio stations or airport radio transmitters that interfere with the normal operation of electronic smart keys.
 - The battery of an electronic smart key may be exhausted. Check the battery inside the electronic smart key. It is recommended to contact a BYD authorised dealer or service provider for inspection as soon as possible.
- If you lose your smart key, it is recommended to contact a BYD authorised dealer or service provider as soon as possible to reduce the risk of vehicle theft or accidents.
- Do not change the transmission frequency arbitrarily, increase the transmission power (including additional transmission frequency amplifier), do not arbitrarily connect the external detection antenna or switch other transmitting detection antennas.
- Do not cause harmful interference to legitimate radio communication services when used; once there is interference, stop using and mining immediately.
- The use of micropower radio equipment must be free from interference of all radio services or from radiation of equipments for

 **CAUTION**

industrial, scientific and medical applications.

- When leaving the vehicle, always carry your key and lock the vehicle. Never leave people (especially children) alone in the vehicle.
- People implanted with pacemakers or defibrillators should stay away from the detection antennas of intelligent entry and start systems, as electromagnetic waves can affect the normal use of such devices. In addition to people implanted with pacemakers or defibrillators, those who use other electronic medical devices should also consult the manufacturer on the use of such devices under the influence of electromagnetic waves. Electromagnetic waves may bring unknown consequences to the use of such medical devices.

Mechanical key

Use the mechanical key (inside the smart key) to lock or unlock the driver's door. When the key is not used, be sure to insert the mechanical key back into the smart key.

Taking out the mechanical key

When using the mechanical key in the electronic smart key, slide the lock-up button in the direction of arrow ① and push the back cover of the smart key in the direction of arrow ②, hook the head hole of the mechanical key with the projection parts at both ends of the back cover of smart key and pull it in the direction of arrow ③ to take out the mechanical key, as shown in the figure.



- After using the mechanical key, insert it in the opposite direction of arrow ③ and close the back cover of the smart key. The mechanical key can only be inserted in one direction.

NFC Card*

- NFC key card* - Place the NFC key card at the mark on the right side mirror to unlock/lock all the doors when the vehicle is powered off.

! CAUTION

- NFC card is an electronic product. The following instructions must be observed to prevent function failure of or damage to the card:
 - Do not place the NFC card in the charging area when the wireless charger is on.
 - Do not attach any object (such as a metal seal or metal phone case) that may cut off electromagnetic waves.
 - Do not place the NFC card in a position exposed to high temperature, such as on the dashboard.
 - Do not bend the card with force.
 - Do not place the card with other hard objects.
- NFC key cards use near-field communication technology,

! CAUTION

requiring a detection distance of less than 0.79 in (2 cm). When identifying, it is recommended to place the NFC card close to the side mirror for 1-2s.

- The NFC smart card is a key configured for the vehicle based on the near field communication method. In order to ensure vehicle safety, handle it with care. If it is lost, going to BYD authorised dealer or service provider for blocking of the lost card and re-configuration is recommended.

Locking/Unlocking Doors

Locking/Unlocking with Mechanical Key

1. Push the left side of a hidden door handle, and turn the right side to get a finger height, holding it by a hand.

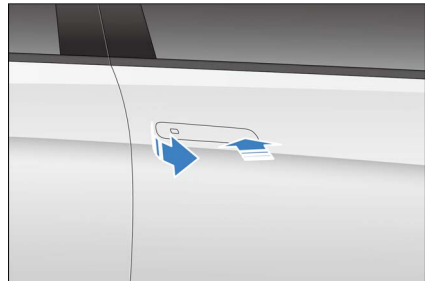

2. Once the left side is extended, pull the middle of the handle outward to extend the handle.



3. Pull the driver's door handle to its maximum angle. Insert, turn, and then pull out the mechanical key. Pull on the door handle to open the door.

- Turn the key counterclockwise.
- Turn the key clockwise.

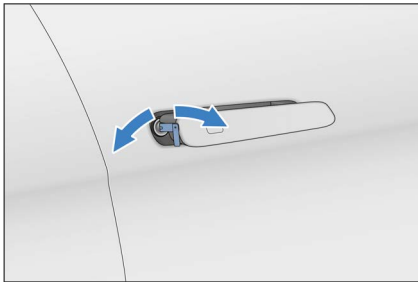

! CAUTION

- After removing the mechanical key, pull the main door handle to open the door.

Opening with Interior Door Handle

- When the vehicle is unlocked, pull the handle once to open the door from inside the vehicle.
- When the vehicle is locked, pull the handle twice to open the door from inside the vehicle.

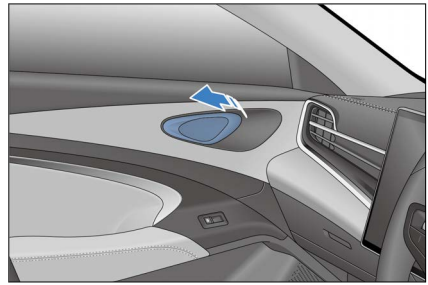

! WARNING

- Do not allow children to play with the door handle, so as to avoid the door opening while driving
- If there are children in the vehicle, make sure to enable the child protection lock function.

! CAUTION

- As this vehicle is equipped with a child protection lock, the rear doors can only be opened with the interior handle when the child protection lock is disabled.

Locking/Unlocking with Smart Key

- The wireless remote control is used to unlock or lock all doors at a close distance, and complete additional functions.
- In the active area, press the associated button on the registered smart key slowly and firmly to lock or unlock all doors.

Locking:

- When all the doors, the bonnet and the boot are closed, press the lock button to lock all the doors. The hidden door handles fold automatically. If the vehicle is shut down, the side mirrors will fold (when the Auto-Fold is enabled) with turn signals flashing

once. If the ignition has not been switched off, the side mirrors will not fold, the turn signals will not flash, and the alarm will sound once. Check whether all doors are securely locked.



- If any door is unlocked, the side mirrors do not fold, the turn signals do not flash, the door handles do not fold and the alarm sounds once.
- If the bonnet or boot is not closed, the side mirrors do not fold*, the turn signals do not flash, and the alarm sounds once.

Unlocking:

- Press the unlock button. All doors are unlocked, the hidden door handles* automatically extend, and the turn signal flashes twice.
- Unlocking all doors with the smart key may turn on interior lights and keep them on for 15 seconds then go out (when the interior light "DOOR" switched is turned on on the infotainment touchscreen), even if no door is opened.
- If the anti-theft alarm system is armed, open any door within 30 seconds after unlocking with the smart key, or all doors will relock automatically and the four door handles retract*.

Finding the vehicle

- When the vehicle is in anti-theft mode, press the lock button. The vehicle

sounds a long beep and turn signals flash 15 times. Use this function to locate the vehicle when it cannot be found.

- When the vehicle is in car search mode, press the lock button again. The vehicle enters the next car search mode.

Raising/Lowering Windows with Smart Key*

- Switch the ignition off.
 - Press and hold the lock button on the smart key to raise the four windows.
 - Press and hold the unlock button on the smart key to lower the four windows.

To enable or disable key unlock/lock/closing window functions, go to infotainment touchscreen  → Vehicle settings → Window and Lock.



CAUTION

- Before activating the remote window closing, please confirm that any body part of passengers in the vehicle will not be stuck or clamped by the window.

Locking/Unlocking with Microswitch

Locking

- When the doors are closed but unlocked, press the front door handle microswitch while carrying the smart key to unlock all doors, then all doors close concurrently. At this time, the hidden door handles retract automatically. If the ignition is off, the side mirrors fold in (when the switch is set to AUTO), and the turn signal flashes once. If the ignition has not been switched off, the side mirrors will

not fold, the turn signals will not flash, and the alarm will sound once.

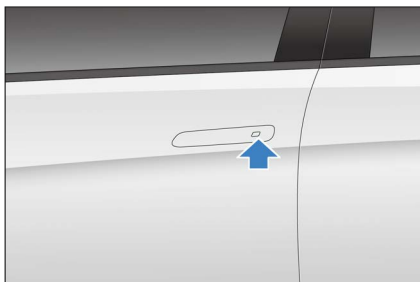

- If any door is not closed, the side mirrors do not fold, the turn signals do not flash, the door handles do not fold and the alarm sounds once.
- If the engine compartment or boot is not closed, the side mirrors do not fold*, the turn signals do not flash, and the alarm sounds once.

Unlocking

- When doors are locked, press the microswitch on the front door handle while carrying the smart key. All doors unlock concurrently. The hidden door handle extends automatically and the turn signal flashes twice.
- If the anti-theft alarm system is armed, open a door within 30 seconds after the unlocking. Otherwise, all doors will be locked automatically again and the four door handles retract*.
- Pressing the microswitch does not work if:
 - This is performed while a door is being opened or closed.
 - The key is in the vehicle.

! REMINDER

- If the smart key is too close to an exterior door handle or window,

! REMINDER

it may not be possible to activate the entry function.

Raising/Lowering Windows with Microswitch

- When the ignition is switched off, press and hold the microswitch while carrying the smart key to roll up or down all windows (lifting the window is open and lowering the window is close by system default).
- To enable or disable this function, go to infotainment touchscreen → → **Vehicle Settings** → **Window and Lock**.

Locking/Unlocking the Boot

Opening the boot with smart key

Double-press the boot release button on the smart key, and the turn signals flash twice.

- Anti-forget key function
 - If the key is placed in the vehicle or in the boot with the vehicle locked, when you close the boot, the vehicle automatically unlocks and turn signals flash twice.



Unlocking the boot with microswitch

- With the vehicle locked, press the rear microswitch while carrying a valid key to unlock the boot.
- With the vehicle unlocked, press the rear microswitch to unlock the boot.



Opening the boot from inside

With the vehicle unlocked, pull up the electrical boot lid button.

- If the vehicle speed is greater than 2 mph (3 km/h), the boot cannot be opened by pulling up the button.



① Boot close button*

- When the boot lid is open and stationary, press the boot closing button to close this lid.
- Press the boot close button again to stop the lid at the current position. If the button is then pressed again, this lid will move in the opposite direction.

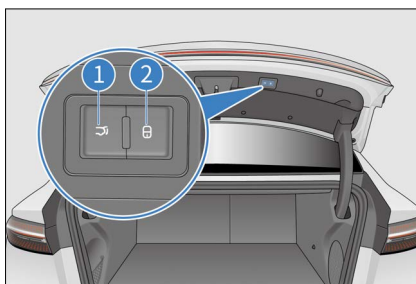

② Vehicle lock button*

- When the ignition is off, pressing the lock switch while carrying a valid smart key closes the boot, locks the entire vehicle, and arms the anti-theft alarm system.

! REMINDER

- Before closing the boot, verify that the doors, windows, sunroof, etc. are closed to avoid property loss.

Emergency Boot Releasing from Inside

1. Pull up the folding release clasp on the seatback to fold the rear seatback.



2. There is an emergency unlocking mechanism on the lid cover, open the lid cover in the vehicle by pulling the emergency opening lever on the left (as shown in the figure).

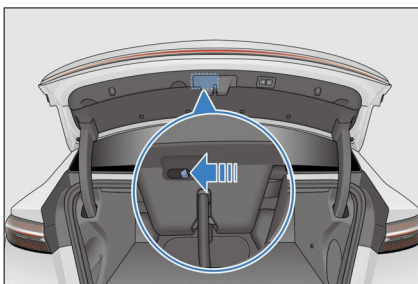

REMINDER

- When the entire vehicle is powered off, the boot can be unlocked from inside the vehicle.

Setting boot opening height*

- Open the boot manually or automatically to the desired position, keep it at this position, and then press and hold the interior boot button for over three seconds. The speaker sounds for one second, indicating that the opening height is successfully set to the current position.
- Set the boot opening height by going to infotainment touchscreen →  → **Vehicle Settings** → **Window and Lock**.

Anti-pinch

If the lid receives a hindering force while it is closing, it will automatically switch to the opposite direction. If it receives a hindering force while it is opening, it will halt.

When the boot fails to act automatically

Manually and completely close the boot for recovery.

When reconnecting the low-voltage battery

Manually close the boot to ensure the power boot lid functions normally.

WARNING

- In order to prevent serious injury, make sure to observe the following precautions:
 - Never try to deliberately activate the anti-pinch function.
 - Make sure to alert people nearby of the lid motion.
 - Make sure hands and fingers are clear from the lid area when it is closing.
 - Make sure the surrounding area is safe when opening or closing the boot.
 - Make sure the boot is properly closed when the vehicle is in motion.
 - Make sure to remove any ice or snow from the area before opening the boot. otherwise the lid may close again.
 - Do not manually interfere in lid motion when it is opening or closing.
 - Be mindful of windy conditions when opening or closing the boot.
 - The anti-pinch function may fail to work if an object is caught right before the boot is fully closed.
 - The lid may start closing before fully opening. Opening or closing the boot on slopes is more difficult than on level ground. Be mindful of the possibility of the lid to move on its own in such conditions. Before loading or unloading the boot, make sure the lid is fully open and secure.

WARNING

- The anti-pinch function may fail depending on the object shape. Be especially careful about hand and fingers.

Locking/Unlocking with NFC Card*

Locking doors

When doors are closed but unlocked, hold the NFC key close to the instruction area on the driver's exterior rearview mirror. All doors can then be locked at the same time. The turn signals will flash once when the vehicle is powered off.

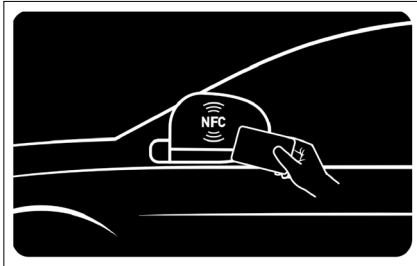

Unlocking doors

When doors are locked, hold the NFC card close to the instruction area on the driver's exterior rearview mirror. Then all doors can be unlocked at the same time. The turn signals flash twice.

- In any of the following cases, doors are not locked/unlocked when the NFC card is held close to the NFC sign on the side mirror on the driver's side:
 - The NFC card is placed close to the designated area on the driver's side mirror while a door is being opened or closed.

WARNING

- The keyless start permission lasts for up to 4 min.

REMINDER

- After unlocking the vehicle in anti-theft mode with NFC key, open any door within 30 seconds or all doors will relock automatically.
- After unlocking with NFC key card, the user can start the vehicle without the key in a stipulated period, while this will be disabled after valid locking.

Locking/Unlocking with Central Locking

Locking or unlocking the vehicle with the central locking

See "Central Locking" in "Driver' Door Switches" in this chapter.

Locking or unlocking doors automatically

- All doors automatically lock at vehicle speeds above 5 mph (8 km/h).
- Press the START/STOP button to switch the ignition off. Then, all doors are locked automatically.

Locking and unlocking all doors concurrently

- When the vehicle is not in anti-theft mode, the backlight of the central lock button turns on if the vehicle is locked and turns off if the vehicle is unlocked.
- Pressing the central lock button locks all doors so that any attempt to open any door from the outside fails. At this time, pull the interior door handle to unlock a door and pull a second time to open it.

! REMINDER

- All doors unlock automatically when the vehicle suffers a strong impact, depending on the impact intensity and accident type.

Emergency Vehicle Locking with Mechanical Key

- When the centre console lock fails, lock the driver door with the mechanical key. Use the key to turn the emergency locking knobs of the other three doors counterclockwise to the locked state, and then close the doors. At this time, the entire vehicle has been locked so that doors cannot be opened with any of the four exterior door handles.
- To unlock the doors, unlock the driver door with the mechanical key first, enter the vehicle, then pull other door handles twice to open the doors.

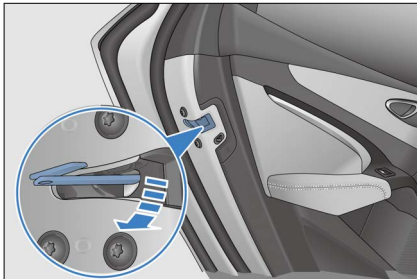

! REMINDER

- Prevent excessive force from distorting or breaking the key during the operation.

Smart Access and Start System

Use the smart key to unlock or lock the vehicle doors and start the vehicle.

Access

Use the smart key to unlock or lock vehicle doors (see **P51** or **P52**.)

! REMINDER

- If the smart key is too close to an exterior door handle or window, it may not be possible to activate the entry function.

Start-up

With the smart key inside, press the brake pedal and the START/STOP button to start the vehicle. (See **P104**.)

! CAUTION

- Do not touch the power button while driving.

Antenna Positions

- ① Interior antenna
- ② Exterior antenna

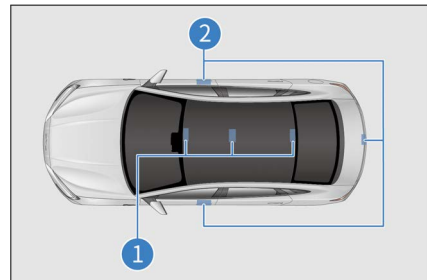

Active Area

The smart access and start functions take effect only when the registered smart key is within the active area.

- ① Active area of the access function: about 3.28 ft (1 m) from the front door handle and the exterior boot switch.

② Active area of the start function: inside the cabin.

If another smart key is near this vehicle's smart key, unlocking may take longer than usual, which is normal.

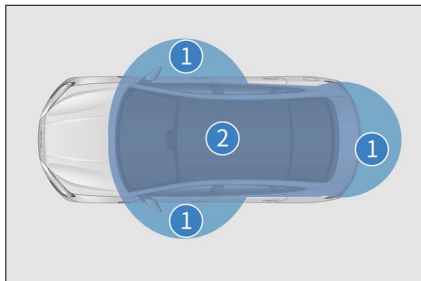

! REMINDER

In the following situation, smart access and start system may not work normally:

- There is a strong electromagnetic field nearby, such as TV towers, power stations, and broadcasting stations.
- The smart key is being carried along with a communication device, such as a two-way radio or mobile phone.
- The smart key is in contact with or covered by a metal object.
- The door handle is operated too quickly.
- Another wireless remote control function is being used nearby.
- When the smart key battery runs out.
- The smart key is close to high-voltage equipment or equipment that produces noise.

! REMINDER

- The smart key is being carried along with another smart key or radio-wave-emitting device.
- Even within the active area, the smart key may not work properly in certain locations, for example, on the dashboard, in the glove box, or on the floor.
- If the smart access system is not working properly and it is impossible to enter the vehicle, the mechanical key can be used to lock/unlock the driver's door, or the wireless remote control function can be used to lock/unlock all doors.
- Pressing the Start/Stop button may not enable the start function due to:
 - If the smart key fails to work, smart key warning light on the instrument cluster lights up and the instrument cluster displays the message "Low key battery".
 - If the smart access and start system cannot work properly due to system failures, bring all smart keys to a BYD authorised dealer or service provider for repair.

Saving battery power

- The smart key communicates with the vehicle even when the vehicle is not running. Therefore, do not leave the smart key in the vehicle or within 6.6 ft (2 meters) from the vehicle.
- Receiving strong electromagnetic waves for a long time drains the battery of the smart key quickly. The smart key must be kept at least 3.3 ft (1 meter) away from the following devices:
 - TVs
 - PCs

- Wireless telephone chargers
- Electroliers
- Fluorescent table lamps

Child Protection Lock

Configuration I

Child protection locks are designed to prevent children in rear seats from accidentally opening rear doors. Such locks are provided on the sides of the left and right rear doors.

- ① Deactivating the child protection lock
- ② Activating the child protection lock

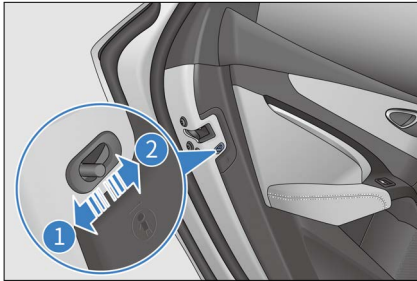

Activating the child protection lock

- Move the latch in the direction of arrow ② to turn on the child protection lock. The door cannot be opened from inside. Use the exterior door handle to open this door.

Deactivating the child protection lock

- Move the latch in the direction of arrow ① to turn off the child protection lock. The door can be opened from inside.

Configuration II

Child protection locks on the driver's door switches are designed to prevent children sitting in the rear seats from inadvertently opening the rear doors.

- ① Child protection lock for the rear left door
- ② Child protection lock for the rear right door

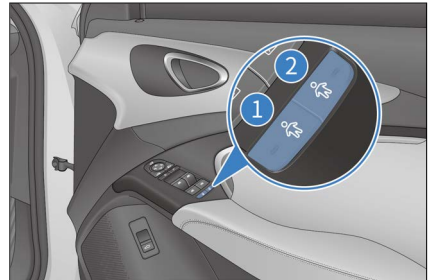

To activate child protection locks, press the child protection lock button ① or ②. The corresponding indicator lights up. At this time, the occupants cannot open the rear door on the corresponding side. To unlock the door, press the child protection lock button for the corresponding side again or use the exterior door handle.

WARNING

- Before driving, especially when a child is in the vehicle, ensure that the doors are closed and the child protection lock function is enabled.
- Proper use of seat belts and activation of child protection lock helps prevent the driver and passengers from being thrown out of the vehicle in an accident, and also prevents a door from being opened accidentally.
- After the child protection lock is locked, doors cannot be opened from inside the car, and the window switch for the corresponding rear door cannot be used to raise or lower the window.

Seats

Seats

When the vehicle is moving, all passengers in the vehicle must fasten their seat belts, and rest their backs upright against the seatback.

WARNING

- Do not drive the vehicle until occupants are seated properly.
- Sitting on a folded seatback or on cargo is prohibited. Improper seating position or improperly fastened seat belts can result in severe personal injury in case of emergency braking or a collision.
- It is prohibited to stand or move around the seats when driving, or passengers may get injured in case of emergency braking or a collision.

Seats adjustment precautions:

Adjust the driver's seat so that the pedals, steering wheel, and dashboard controls are all within the driver's easy control.

REMINDER

- Do not adjust the seat while the vehicle is in motion, as unpredictable seat movement can cause the loss of vehicle control at this time.
- While adjusting a seat, do not let it hit against any passenger or the luggage.
- After manually adjusting the seat, always check that it is securely locked into place by attempting to push it forward and backward.

REMINDER

- After adjusting the seatback, lean back to confirm the seatback has been locked.
- Do not place any items under the seats. The driver may lose control of the vehicle because items placed there affect the seat locking mechanism or accidentally push up the seat position adjustment lever, causing the seat to move suddenly.
- When adjusting the seat, do not place your hand under the seat or near its operating parts, to prevent being crushed.

Adjusting Front Seats

Adjusting Front Seats with Power

Power front seat adjustment include seat position and cushion height* adjustment, seat base* and seatback angle adjustment. Choose the following methods according to the functions available in your vehicle.

① Seat position adjustment switch

- Move the seat position adjustment switch back or forth to move the seat backward or forward.
- Move the front end of the switch up or down to change the seat base angle.
- Move the rear end of the switch up or down to raise or lower the seat.

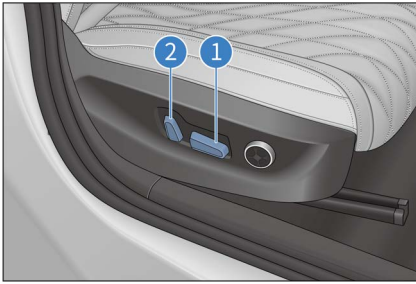

② Seatback angle adjustment switch

- Toggle the seatback angle adjustment switch to adjust the angle.

! REMINDER

- Releasing the switch stops the seat in this position. Do not place anything under the seat as this may prevent the seat from operating.

Adjusting the lumbar support*

The seatback profile can be adjusted to fit the curvature of the occupant's lumbar spine.

- Press the front or rear portion of the switch to increase or decrease the curvature.
- Press the upper or lower portion of the switch to extend the curvature up or down.

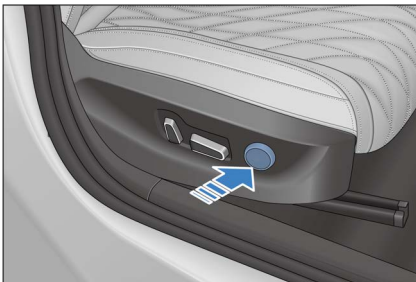

Memory System*

Memory switch position

The memory system switch is on the infotainment touchscreen with 2 memory positions: 1 and 2.

Setting function

- Memory setting conditions
 - The vehicle is powered on with no vehicle speed.
 - The driver's seat, side mirrors and steering wheel have been adjusted to the desired positions.
 - No operation is made on the driver's seat, side mirrors and steering wheel.

Memory setting method

- Memory setting in OK mode
 - Press the "SET" button on the seat memory switch, and press either "1" or "2". Then the positions of the seats and side mirrors will be remembered, and the memory setting finishes.
 - Press and release the "SET" button on the seat memory switch, and press either "1" or "2". Then the side mirrors memory system is activated.

If the position button on the memory switch has already been set, the position set will be overwritten.

Memory wake-up function

Memory wake-up function in OK mode

- With the gearshift lever in the "P" position, tap 1 or 2 for the memory system to restore to the previous position of the driver seat and side mirrors if the following conditions are met:
 - The vehicle is not in anti-theft mode.
 - No speed.
 - Memory switch signals are valid.

- No operation is made on the driver's seat, side mirrors and steering wheel.

Heating and Ventilation System*

- Enable or disable the ventilation in infotainment touchscreen →  → **A/C** → seats operation control.
- Tap "Drop-down" on the homepage of the infotainment system to operate the seat heating and ventilation setting buttons.

Heating system adjustment

- Seat heating: Control the operation mode of the heating pad by using the seat heating switch. The heating function has two modes.
 - After each power-on, the driver's seat remembers the last mode, and the initial heating state of the passenger's seat is Off.
- Press the switch to select the operation mode of the seat heater in the 1st gear or 2nd gear.
- Press the OFF gear to deactivate the heating function.

Ventilation adjustment

- Seat ventilation: Control the operation mode of the ventilation fan by using the seat ventilation switch. Seat ventilation has two modes.
 - After each power-on, the driver's seat remembers the last mode, and the initial ventilation state of the passenger's seat is Off.
- Press the switch to select the operation mode of the seat ventilation in the 1st gear or 2nd gear.
- Press the OFF gear to deactivate the ventilation function.

Ventilation and heating functions cannot be turned on at the same time.

- Press the ventilation switch to make the ventilator work; if the heating switch is then pressed, the ventilator will stop and the heater will start to work.
- Press the heating switch to make the heater work; if the ventilation switch is then pressed, the heater will stop and the ventilator will start to work.

Folding Rear Seats

Pull the strap on the rear seat to fold the bench.



CAUTION

- Please fold or unfold the rear seats at a moderate speed. Avoid quickly lowering or pulling up seatbacks to prevent damages to or malfunction of rear seats and the seat belts.
- Ensure that the left and right seat belts expose when folding or recovering the rear seat to avoid the seat belts being stuck between the rear seat and the flanks.

Rear Seat Head Supports

Lifting the head support

Lift the head support to a proper position, and release it after hearing a locking sound.

Lowering the head support

Press and hold the head support adjustment button, lower the head support to a proper position, slightly lift the head support and release the button after hearing a locking sound.

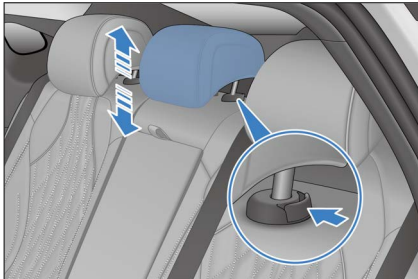

Removing the head support

Press and hold the head support adjustment button, remove the head support and release the button.

Installing the head support

Insert the head support post into the bushing with the grooves facing forward. Press and hold the head support adjustment button, lower the head support to a proper position, slightly lift the head support and release the button after hearing a locking sound.

! REMINDER

- When adjusting head support height, align the occupant's ear tip line with the centre line of the head support.
- After adjusting the head support, press the head support down to confirm that it is locked.
- Do not drive the vehicle without head supports.
- Do not attach any object to the head support lever.

Steering Wheel

Steering Wheel

Steering Wheel Switches

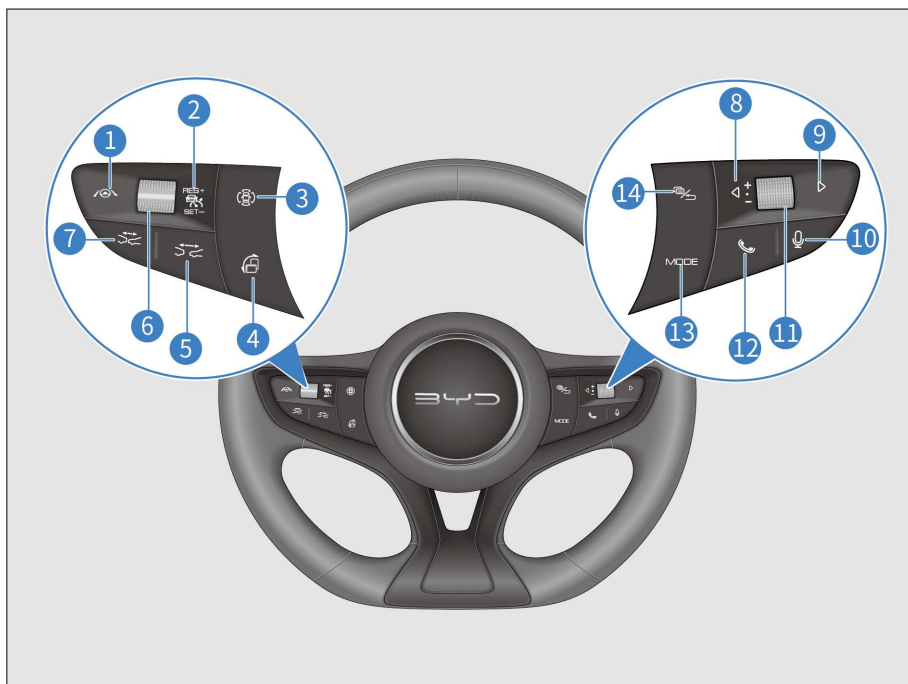

- | | | | |
|---|------------------|----|-------------------------|
| 1 | ADAS button | 8 | Left |
| 2 | ACC switch | 9 | Right |
| 3 | Panoramic view | 10 | Speech recognition |
| 4 | Whirling button | 11 | Scroll button |
| 5 | Distance + | 12 | Call |
| 6 | +/Reset or -/Set | 13 | Mode |
| 7 | Distance - | 14 | Instrument cluster/Back |

Left-hand buttons

ACC switch

- Turns the ACC system on or off.

+/Reset

- Activates the adaptive cruise control (ACC) system and uses the previous system settings.

-/Set

- Sets the current speed to the target cruise speed.

Distance -

- Reduces the distance from the vehicle ahead by one notch when the ACC function is enabled. A total of four notches are available.

Distance +

- Increases the distance by one notch when the ACC function is enabled. A total of four notches are available.



CAUTION

For instructions on using cruise control, see **P111**

Whirling button

- Press this button to rotate the infotainment touchscreen.

Panoramic view

- Turns panoramic view off in panoramic view mode, turns it on when it is not in the mode.

ADAS button

- Turns ICC on or off.

Right buttons

Scroll button

- Adjusting infotainment system volume when the instrument cluster is not in menu mode:
 - Roll the scroll button upward to increase volume.
 - Roll the scroll button downward to decrease volume.
 - Press down the button to mute.
- When the instrument cluster is in menu mode:

- Roll the scroll button upward to select the upper level-2 or level-3 menu items.
- Roll the scroll button downward to select the lower level-2 or level-3 menu items.
- Press down the button to go to the next-level menu or confirm the current setting.



CAUTION

- The infotainment system is muted once the instrument cluster is set to the menu mode. To adjust infotainment system volume, exit the instrument cluster menu mode first.

Left/Right buttons

1. Infotainment system

- In radio mode:
 - Press the ◀ button to select previous radio station.
 - Press the ▶ button to select next radio station.
- When the infotainment system is in USB/Bluetooth music/third-party music app/other modes:
 - Press the ◀ button to play the previous track (track number -1).
 - Press the ◀ button to select a record upward on the Bluetooth call record or phonebook screen.
 - Press the ▶ button to play the next track (track number +1).
 - Press the ▶ button to select a record downward on the Bluetooth call record or phonebook screen.

2. Instrument cluster

- When the instrument cluster is in menu mode:
 - Press the ◀ button to switch to level-1 menu and its submenus on the left.
 - Press the ▶ button to switch to level-1 menu and its submenus on the right.

Call

- Press this button to make or receive a call. (The audio system is muted at the same time.)
- When a Bluetooth-unrelated screen is currently displayed, press this button to switch to the phone selection screen if Bluetooth is disconnected, or to the Dial screen if Bluetooth is connected.
- After entering a phone number on the Dial screen or selecting a record on the Call Log or Contacts screen, press this button to dial the number.
- When Bluetooth is connected, but no phone number is entered on the Dial screen, press this button to switch to the Call Log screen. Press this button again to call the first dialed number on the call history.

Speech recognition

- Press this button for the infotainment touchscreen to switch to the voice recognition screen.
- Press this button again to re-enter a voice command.

Instrument cluster/Back

- When the instrument cluster is not in the menu mode, press this button to view the instrument cluster menu.
- When the instrument cluster is in menu mode, press this button to return to the upper-level screen, or to exit the menu if there is no upper-level screen.

- When dialing on the Bluetooth interface, press it to end the call.

Mode

- Selecting a mode: Press the Mode button to switch between media apps, peripherals, and pre-installed third-party audio/video apps.

Horn

- Press the horn button area to honk the horn, and release to stop honking.

CAUTION

- Avoid pressing honking for too long, as the horn may be damaged.

REMINDER

- Observe the traffic laws and use the horn properly.

Adjusting the Steering Wheel Manually*

- To adjust the steering wheel position, hold it and operate as follows:
 - Push down the steering wheel adjustment handle, adjust the steering wheel to the desired position, and then return the handle to its original position.

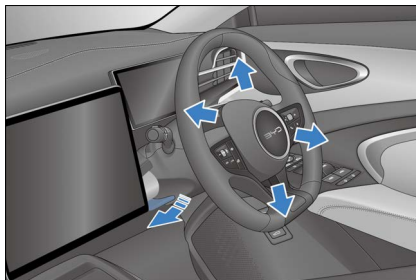

! REMINDER

- Never adjust the steering wheel while driving, as this is under risk of impaired vehicle control, which can lead to accidents.
- After adjusting the steering wheel, move it up and down to verify that it is securely locked.

Power-Assisted Steering Mode Settings

- The feel of steering assistance varies from person to person, and so do the evaluation and needs for this feel.
- To set the steering mode, go to infotainment touchscreen  → Vehicle Settings → Intelligent Chassis → Steering Assist setting and select Comfort or Sport.

! REMINDER

- Setting the power steering to sport mode is suggested if the steering wheel feels light when the vehicle is running at a high speed.

Switches

Light Switches

Set the light switch to  to turn off all lights except for daytime running lights.

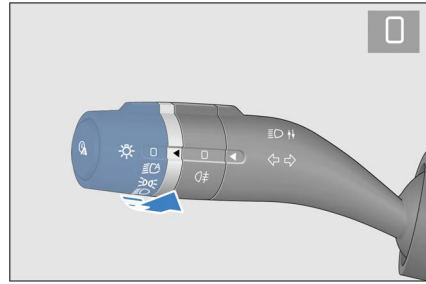

Auto lights

Set the light switch to . The body control module captures the brightness data from the light intensity sensor to automatically turn the position lights and low beam on or off.

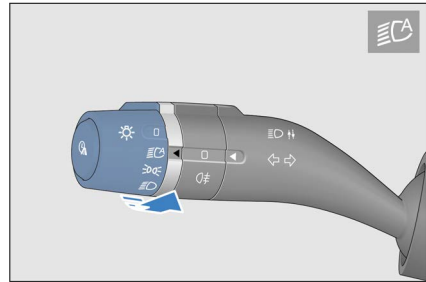

! REMINDER

- The light intensity sensor is located on the top of the windscreen. Do not block the sensor or let anything splash on it.

Position lights

Set the light switch to  to turn on position lights.

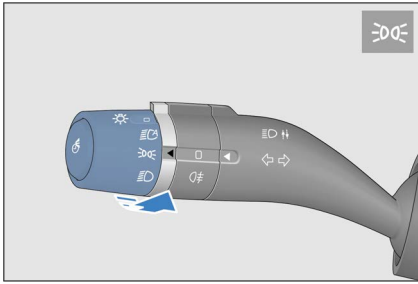

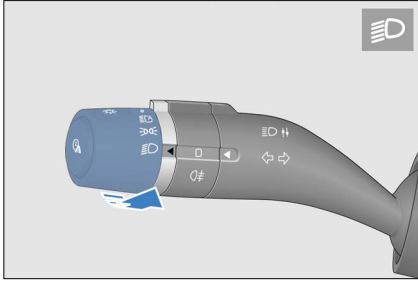

Low beam

Set the light switch to  to turn on the low beam.



Rear fog lights

Set the light switch to  and rotate the fog light dial to  to turn on rear fog lights.

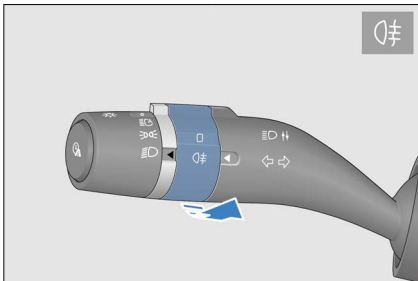

High beam

Set the light switch to  and push the light switch lever down (away from the

steering wheel) to turn on the high beam. Push the light switch handle down again to turn the high beam off.

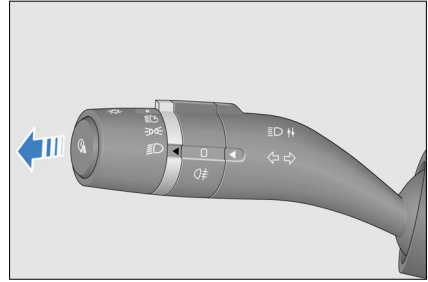

Overtaking light

Pull up the lever (toward the steering wheel) to turn on the overtaking light. Release the lever to reset the light switch automatically, and the overtaking light turns off.

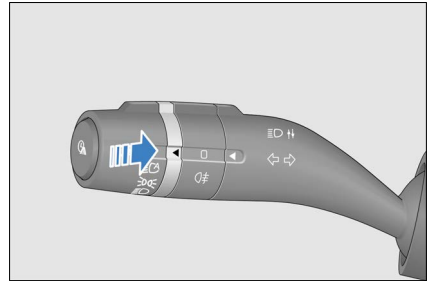

Turn signals

- Push up the lever to signal right turn. The right turn signal and its indicator on the instrument cluster flash.
- Pull down the lever to signal left turn. The left turn signal and its indicator on the instrument cluster flash.

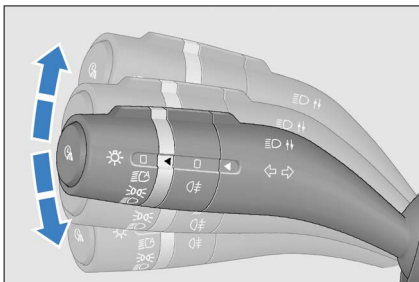

CAUTION

- Once turned on, turn signals continue flashing even after the handle is released. They will turn off after the turn is complete. Depending on the driver's habit, the turn signal will reset after the vehicle turns around under some extreme conditions.

Auto light off

- Conditions to activate the auto light off function: To activate this function, set the light switch to or and switch off the vehicle power.
- When the function is activated, the headlights, position lights, rear fog lights, and high beams turn off in 10 seconds if the driver door is closed.
- When the function is activated, the headlights, position lights, rear fog lights and high beams turn off in 10 minutes if the driver's door is open.
- After the lights turn off automatically, if the light status changes, the lights come on in the new status. If the conditions to activate the auto light off function are still met, the function is activated again.
- Disabling of the auto light off function: When the vehicle is powered on, the auto light off function is disabled,

and the light switch can be operated normally.

- If the auto light off function has turned off the lights and the anti-theft alarm system has been armed, disarming the alarm system makes the lights come on again automatically. If the driver's door remains closed, the lights go off again after 10 seconds. But if any door is open, it turns off the light in 10 minutes.

Advanced turn-on/delayed turn-off (Follow me home)* of headlights





- Delayed turn-off of headlights:
 - When the combination switch is turned to , or and you are about to leave the vehicle and set the power mode to "OFF", execute the "Follow me home" function and corresponding lights will light up for 10 seconds (or a set time).
- Advanced turn-on of headlights:
 - When the combination switch is turned to , or and you unlock the vehicle while approaching to execute the "Follow me home" function, corresponding lights will light up for 10 seconds (or a set time).

CAUTION



- The time for the advanced turn-on/delayed turn-off of the headlights is 10 seconds by default, but you can change it in the infotainment interface.

Wiper Switch

Front Windscreen Wipers and Washer

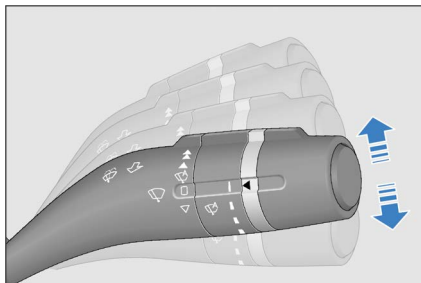
- The lever is used to control the windscreen wipers and washer. It has five modes:
 -  : Fast
 -  : Slow
 -  : Auto wipers/intermittent
 -  : Off
 -  : Point-wiping



- Push up or pull down the lever to select a mode.
- In slow and fast modes, the wiper operates continuously.
- Pulling down the lever from the  position activates the point-wiping mode . The wipers wipe at a low speed until you release the lever.

Auto wipers/Intermittent

- The rain sensor automatically controls the operation mode of wipers based on the rainfall, and it is located in front of the interior rearview mirror on the front windscreen inside the vehicle.
- To use the automatic wiper function, turn the wiper switch to the automatic mode, go to infotainment touchscreen

→  → **Vehicle Settings** → **Greeting** and toggle **Automatic Wiper** on.

- To use the intermittent wiper function, turn the wiper switch to the automatic mode, and toggle Automatic Wiper off in infotainment touchscreen →  → **Vehicle Settings** → **Greeting**.
- The automatic wiper function has four sensitivity levels. The higher the lever, the higher the sensitivity. When using the automatic wiper function, change the sensitivity by adjusting the toggle based on real-time rain conditions. If the wiper reacts to rain too quickly, reduce the sensitivity; if the wiper reacts to rain too slowly, increase the sensitivity.

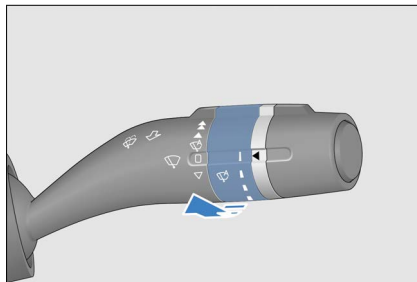

Front windscreen wipers and washer

- To clean the front windscreen, pull the wiper switch lever backward (towards the steering wheel) so that the washer spray washing fluid while the wipers operate.
- The washer spray will stop when the stick is released, and the wipers will operate twice then stop.

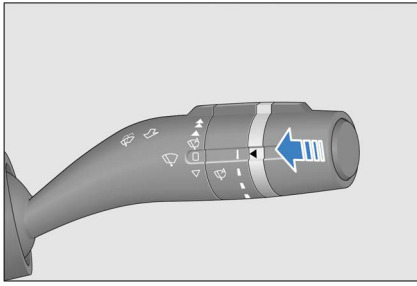

Driver's Door Switches

Power Window Switches

- When the ignition switch is on OK, all the window switches can lift up and down the window. After the vehicle is powered OFF, no power windows can be regulated.

Driver side windows control switch

There are two gears of window control, like the figure ① and ②.

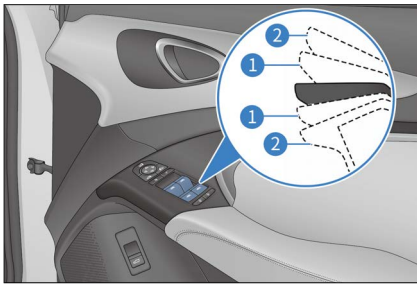

Manual operation

- Press the window regulator switch to ① mode position and keep it (for vehicles without anti-pinch function, directly press and hold the window regulator switch) to lower the window; releasing the switch can immediately stop the window lowering; pull up the window regulator switch to ① mode position and keep it (for vehicles without anti-pinch function, directly pull up and hold the window regulator

switch) to raise the window; releasing the switch can immediately stop the window raising.

Auto lifting

- Press the window regulator switch to ② mode position and release it to automatically lower the window; pull up the window switch to ② mode position and release it to automatically raise the window.

Anti-pinch

- If someone or an object is caught by the window when it is rolling up, the window stops and rolls down automatically.

! REMINDER

- Do not intentionally activate the anti-pinch function by jamming any part of your body into the window.
- The anti-pinch function may not work if an object is jammed into the window when it is almost completely closed.
- Windows with anti-pinch function can control opening or closing the window* by intelligent voice assist.

Automatic window rolling-up and anti-pinch failure

- If the window working indicator flashes, it indicates that the automatic window closing and anti-pinch functions fail. In this case, follow the steps given below to restore the functions:
 - Pull up and hold the manual closing gear of the regulator switch to allow the window to lift to the top position and keep the window stall at the top position for 400 ms, until the switch indicator changes

from flashing to staying on. This means that initialisation has been completed. The anti-pinch module has all functions except the soft stop function. When the window glass runs down to the locked rotation (400 ms), it has a soft stop function.

Delay function

- After the vehicle is powered off, if the front doors are not open, the four window switches has a 10-minute roll-up/down delay period. During this period, the windows can still be rolled up and down. If either of the front doors is opened during this period, the delay function is cancelled, and the switches can no longer be used to operate the windows.

WARNING

- Before closing a power window, ensure occupants' hands are not placed upon the window glass; pinching of hands or fingers can result in serious injuries.

Window lock button

- Press the "window lock" button, the driver can control the windows on the four doors, and the window regulator switches on the rear passenger sides are turned off with indicators off at the same time.

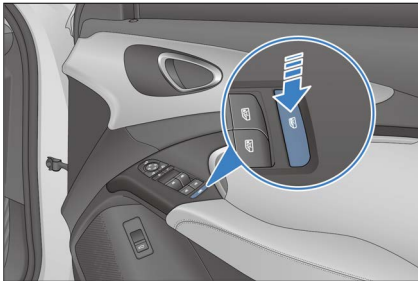

Central Locking

The driver door is equipped with power door lock switches. Both switches can lock or unlock all doors.

① Locking

Press the central lock button. All doors are locked and the red lock indicator lights up.



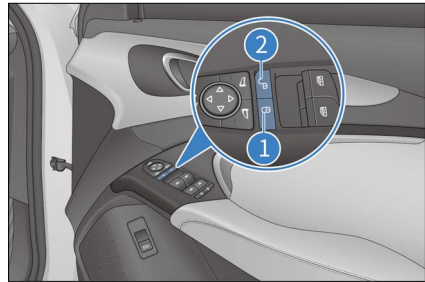

② Unlocking

Press the central unlock button. All doors are unlocked and the red lock indicator turns off.



Side Mirror Switches

Side mirror selection buttons

-  : Left side mirror button
-  : Right side mirror button
-  : Side mirror adjustment buttons
 - Press this button to adjust the side mirror lens to a right position.
-  : Power side mirror fold switch
 - Press this button to fold the side mirrors.



! REMINDER

- If the side mirrors get frozen, do not operate the controller or scrape their surface. Deicing spray should be used.

Passenger Side Window Switch

When the ignition is on, use the front left and rear door window switches to operate the respective windows.

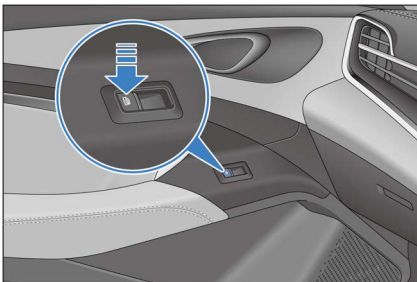

Odometer Switch

- Press the odometer switch to switch between "Total Mileage" - "Mileage 1" - "Mileage 2" - "Total Mileage". The switching status is displayed accordingly on the instrument cluster.

- Press and hold "Mileage 1" and "Mileage 2" to clear the mileage information.

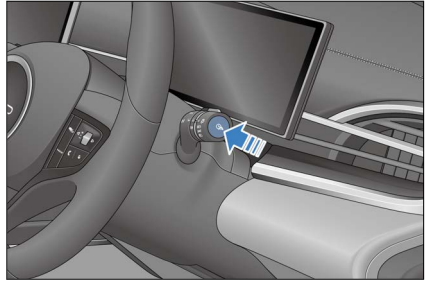

Mode Switches

① Snow mode button

- Press down the snow mode switch ① to put the vehicle in snow mode.
- This mode is recommended on fairly strong surfaces covered in slippery materials such as grass, snow, ice, or gravel.
- In snow mode, traction and control features are optimised, but it is recommended to press the accelerator pedal slowly and control the speed.

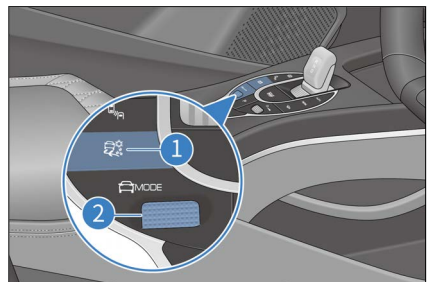

! CAUTION

- ESC system may limit the vehicle's torque. Therefore, temporarily shutting down the system may

CAUTION

help if the vehicle skids and gets stuck in soft snow. The ESC system must be restarted after conditions are back to normal (See ESC operation instructions).



- Roll the scroll button ② to switch ECO, NORMAL and SPORT modes cyclically.

Front Passenger Airbag Switch (PAB)

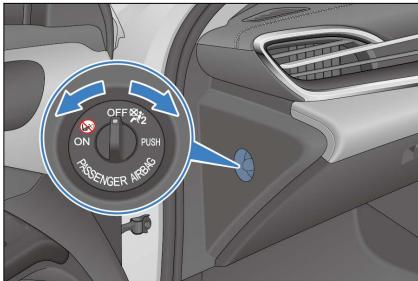

Front passenger airbag switch (PAB Switch)

- The front passenger airbag can be activated/deactivated if the car is equipped with a passenger airbag switch.
- Before driving, repeatedly check the PAB switch status based on the seating situation of the front passenger seat to confirm that the PAB is in the correct state.



- Enable or disable the front passenger airbag according to the use of the front passenger seat:
 - When the switch is ON, the front passenger airbag is activated. The front passenger airbag indicator "PASSENGER AIRBAG" is solid on, "ON" and  come on, and "OFF" and  are off. The front passenger

airbag deploys in the event of a moderate to severe collision that meets the necessary deployment conditions.

- When the switch is OFF, the front passenger airbag is deactivated. The passenger airbag indicator "PASSENGER AIRBAG" is solid on, "ON" and  are off, and "OFF" and  come on. The front passenger airbag do not deploy in the event of a moderate to severe collision that meets the necessary deployment conditions.

WARNING

- When the front passenger seat is occupied with an adult, the passenger airbag switch must be turned to "ON" to always keep the front passenger airbag active.
- When the front passenger seat is occupied with an infant or child in a rear-facing child restraint, the driver should check that the PAB switch is off and the PAB is disabled.
- If the front passenger airbag remains active when the passenger airbag switch is off, immediately contact a BYD authorised dealer or service provider.
- If the recommendations above are not followed, there is a high risk of serious passenger injury or even casualty.



CAUTION

- To prevent damage to the airbag system, please operate PAB switch when the vehicle is on "OFF".

CAUTION

- The rear seat is the preferred choice for installing a child restraint.

Hazard Warning Light Switch

When the  button is pressed, all turn signals and turn signal indicators on the instrument cluster start flashing. They all stop flashing when the  button is pressed again.

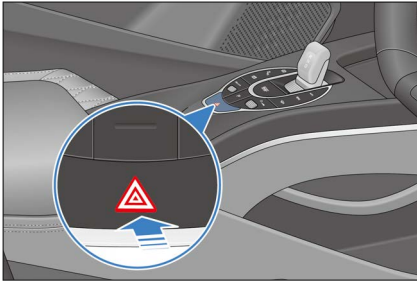

CAUTION

- The hazard warning lights are used to alert drivers and pedestrians of possible risks.

Emergency Call (E-Call)*

E-Call status indicator

E-call is short for "emergency call". When this vehicle suffers a serious collision or gets in an emergency, pressing this button connects to the call centre with the highest priority. The customer service staff will obtain important user and vehicle data, and will assist the user in escaping danger, dispatching an ambulance to the scene immediately if necessary to ensure the user's safety.



- Pressing and holding the SOS button for 1 second $\leq t \leq 10$ seconds triggers the E-Call system manually, and pressing and holding the button for 10-20 seconds does not.
- To cancel an emergency call made by mistake, press the SOS button a second time within five seconds.
- The E-Call system activates automatically in the event of airbag deployment or the detection of a severe collision.
- When triggered, the system automatically makes an emergency call and communicates standard information to a public safety answering point.

CAUTION

- The SOS button will be considered to be short-circuited (button stuck) if you press and hold the SOS button for over 20 seconds. In that case, the E-Call cannot be triggered manually.
- The dialed emergency call cannot be cancelled manually. The E-Call system will begin 60-minute callback time after the call is hung up by the public safety answering point or is not answered when it has been dialed 10 consecutive times.

Status	LED indicator	Beeping
Ignition off or E-Call system failure	Off	\
Power-on self-check mode	Flashing fast - 2 Hz	\
Ignition on and self-check passed	Solid on if self-check is passed	\
E-Call connecting	Flashing - 1 Hz	A beep
E-Call connected	Flashing - 1 Hz	A beep
E-Call ended	Solid on	Two beeps after E-Call ends
Callback time (60 minutes by default)	Flashing extremely slowly - 0.2 Hz	\

Interior Light Switch

Configuration 1 Front Interior Lights Switches



Configuration 2 Side Interior Light Switch



When the vehicle is not powered OFF and the "DOOR" gear switch is turned on, touch the interior light switch while the

door is open, the interior light will switch between high and low lighting intensity, and will not go out; when the vehicle is powered OFF and the "DOOR" gear switch is turned on, the interior light will go out after the door is opened for a period of time. If there are other operations during this period, the timer will be restarted. (To turn on or off the engine sound simulator, slide down the top status bar on the infotainment screen to display the shortcut page.)

Ambient Lights*

To control the brightness, colour and area of the ambient light, go to infotainment touchscreen →  → **Vehicle Settings** → **Ambient Light**.

04

USING AND DRIVING

Charging/Discharging Instructions..	78
Battery.....	93
Usage Precautions.....	96
Starting and Driving.....	103
Driver Assistance.....	111
Other Main Functions.....	144

Charging/ Discharging Instructions

Charging/Discharging Instructions

- The charging equipment is a high-voltage electrical device. Minors are prohibited to charge or touch it. Keep minors away from the vehicle when charging.
- Charging may affect medical or implanted electronic devices. Consult the device manufacturer before charging.
- Charge the vehicle in a relatively safe environment, and avoid charging in damp areas, or areas with fire or heat sources.
 - Protect the charging equipment against water contact on rainy days.
- Before charging:
 - Ensure that power supply equipment, charging connector, charge port, and charging connection device are free of defects, such as cable wear, rusted ports, cracked casings, or foreign objects in the ports.
 - Do not charge the vehicle when the charging connector's or port's plug, socket, or metal terminals are loose or damaged by rust or corrosion.
 - When the charging connector, port, power plug, or socket is visibly stained or damp, wipe them with a dry and clean cloth to ensure the connection is dry and clean.
- Use charging equipment that complies with local standards.
- To avoid charging failure or fire, do not modify, disassemble, or repair the charging equipment and related ports.
- Do not use charging equipment that does not meet safety standards or has potential safety hazards. Do not allow children to use the charging equipment and keep animals away from the vehicle while charging.
- Ensure that your hands are properly dry before charging.
- If anything abnormal is found in the vehicle or charging equipment during charging, stop immediately and contact a BYD authorised dealer or service provider.
- Always observe the following charging precautions to prevent damage to the vehicle:
 - Do not shake the charging connector, otherwise the vehicle charge port may be damaged.
 - Whenever possible, do not charge the vehicle during a thunderstorm, or there will be a risk of lightning strikes.
- Do not open the bonnet for maintenance while charging.
- After charging, do not disconnect the charging equipment with wet hands or while standing on any wet surface.
 - Before driving, ensure that the charging equipment is disconnected from the charge port.

Charging Precautions

- When the State of Charge(SOC) on the instrument cluster turns red, the power battery is about to be exhausted. Please charge it immediately, otherwise the service life of the power battery will be reduced.

- Mode 2 charging means charging with an AC charging connector supplied with the vehicle. It is recommended to use the dedicated AC lines and power sockets meeting local standards to avoid line damage and protective trip due to high-power charging, affecting the normal use of other equipment.
- Avoiding damage to the charging equipment (precautions for charging equipment):
 - Prevent the charging equipment from suffering any mechanical impact.
 - Do not place the charging equipment near heaters or other heat sources.
- Before charging:
 - Make sure that the charging connector and charge port are free of foreign objects, and that the protective cap of the charging connector terminal does not get loose or deformed.
 - Hold the charging connector, align the connector with the charge port and push it in, making sure that they are properly connected.
- When charging is complete:
 - Stop charging first and make sure the charge port is unlocked.
 - Pull the charging connector.
 - Do not force the charging connector out while the charge port is locked, otherwise the charge port may be damaged.
- It is suggested to switch the ignition off before charging.
- Precautions:
 - Starting the vehicle to use A/C. To ensure the charging power, it is recommended to turn off A/C.
 - It is recommended to park the vehicle in a ventilated area and there should not be any occupant inside during charging.
 - The vehicle system stops charging automatically when the high-voltage battery is fully charged.
 - To stop charging before it is full, turn off the charging machine before disconnecting the charging connector. In mode 2 charging, remove the charging connector and then the power plug.
 - When charging is complete and the charging connector is unplugged, make sure that the charge port cap and door are closed, otherwise water or foreign materials may enter the port and affect its normal use.
 - During DC charging, the DC charging power is relatively small during the period to identify the real capability of the charging pile and allow the charging pile to exert its maximum output capacity, thereby bringing a better charging experience to users. (Only motor booster DC Charge)
 - Before starting the vehicle, ensure that the charging equipment is disconnected. The locking mechanism can damage the charging equipment and the vehicle if the vehicle is started with the charging connector incorrectly inserted.
 - When the temperature is low, it is recommended to charge the vehicle in heated indoor space.
 - When the temperature is high, charging in a cool, ventilated place is recommended.
 - Battery temperatures that are too low or too high can compromise vehicle charging performance.
 - The temperature control system can improve low-temperature charging

capacity of the battery. Due to output capacity limitations of charging piles, the charging time is extended, the heating time becomes longer and the power consumption of heating is increased. It's the normal phenomenon.

- For faster low-temperature DC charging, charging from low SOC is recommended because, due to the low battery temperature, the charging current is small for vehicles with high SOC in low-temperature environments.
- To improve your experience at low temperatures, it is recommended that you charge the vehicle immediately after using it, as the battery is relatively hot and has better charging performance.
- Turning A/C on during low-temperature charging affects the performance of battery temperature control system and charging performance.
- It is normal that when the battery temperature control system is working during charging, the charging power displayed on the instrument cluster may fluctuate temporarily.
- Before charging is complete, battery equalisation is activated for longer battery life and thus the charging time may be longer.
- The use of A/C may worsen battery temperature control system performance in DC charging at high temperatures, resulting in lower charging performance and longer charging time. To ensure charging efficiency, it is recommended to keep the A/C off during charging.
- When the heating or cooling function is enabled during charging, it is normal that both charging time and power consumption increase slightly.
- During charging and a period after charging, battery cooling may start, and the compressor, fan and other components work when necessary. It is normal that there will be some noise under the bonnet.
- During charging, the estimated remaining time to full charge is displayed on the instrument cluster or infotainment touchscreen. It is normal that the remaining time to full charge may vary slightly, depending on the temperatures, SOC, and charging facilities. Before charging is completed, "Calculating..." is displayed on the instrument cluster.
- If the charge port door is frozen due to weather or other reasons, do not force it open.
- If the vehicle will not be used for longer periods of time afterwards, make sure to fully charge its high-voltage battery before use. In case of idle periods, it is recommended to charge the battery every three months in order to prolong its service life.

REMINDER

- Do not open the charge port door forcibly when it is locked.
- Do not force the charging connector in or out while the charge port is locked.
- Do not close the charge port door when the port cap is fully open.
- When the vehicle is charged with an external power supply, it is normal that the cooling fan and A/C compressor may operate automatically for the high-voltage battery to cool down.

Charging Method

The pure electric vehicle is driven by electric energy supplied from the high-voltage battery. To prevent insufficient power of the high-voltage battery affecting the vehicle driving experience, it is very important to charge the vehicle in time and estimate the power demand before driving.

Vehicle Charging Method:

1. Using Mode 2 Charging Cable*
 2. Charging with AC Charging Piles*
 3. Using DC Chargers*
- The charging time of power battery varies with the charging mode, current

SOC, real-time temperature, service time, ambient temperature and other conditions.

- Use charging equipment that complies with local standards.

Charging Mode

- Charging Reservation (Only AC): Charge the vehicle regularly at a scheduled charging time set by the user.
- Immediate charging: Charging starts after the charging connector is connected.

General Charging Troubleshooting

Fault	Possible Cause	Solution
Charger is connected, charge starts, but battery will not charge.	The high-voltage battery has been fully charged.	When the high-voltage battery is fully charged, the charging stops automatically.
	High-voltage battery temperature is too high or too low	Keep the vehicle in an environment with appropriate temperature and charge it when the temperature becomes normal.
	Low-voltage battery over-discharges	Replace the low-voltage battery.
	Charging equipment failure	If it is verified that the charging equipment's power indicator is working properly, or that there are no other unusual indications, change the charging equipment or contact the charging equipment supplier.
Charging stops midway	Vehicle display fails.	Verify that there is a charging system fault message on the instrument cluster, then stop the charging. It is recommended to contact a BYD authorised dealer or service provider.
	AC grid outage	During AC charging, if power supply resumes after short-time outage of the external power grid, BYD charging equipment will re-start charging automatically and no re-connection of the charging equipment is required.

Fault	Possible Cause	Solution
	Charging cable is not connected properly	Verify that the charging connection cable is not loosely connected.
	Charging connection switch is pressed.	If the charging connection switch is pressed, the charging will stop. The charging connection should be connected again to start charging.
	High-voltage battery temperature is too high or too low	Charging stops automatically if the high-voltage battery overheating warning light comes out on the instrument cluster. Charge the vehicle when the battery temperature returns to a normal level.
	Vehicle or charging pile failure	If there is any fault prompt for the charging pile or the vehicle, it is recommended to contact a BYD authorised dealer or service provider.

Charging

- Check before charging:
 - Check the charging device for abnormalities such as cracked housing, worn cable, rusted plug, or foreign materials.
 - Do not charge when the charging connection becomes loose.
 - Make sure the port is clear of fluids or foreign objects, and its metal terminals are not rusty or corroded.
- Do not charge in any of these cases. Otherwise, personal injury may occur due to short circuit or electric shock.

Using Mode 2 Charging Cable*

1. Equipment

- Connect the vehicle to an outlet that meets local standards to charge the vehicle.
- A household socket meeting local standards must be used in order to avoid line damage or tripping due to high-power charging, which may affect the normal use of other devices.

- This EV Mode 2 charging cable includes a power plug (complying with local standards), a charging connector, a control box, and a charging cable. The plug is connected to a standard household power socket, and the charging connector to the vehicle's charge port.
- Charging time: Refer to the charging time message on the instrument cluster.

WARNING

- See "Charging Instructions" for charging safety warnings.
- The highest working temperature allowed for the product is 122°F (50°C). Store the product in a cool and dry place when it is not in use.
- When charging, do not place the equipment in the boot, under the front of the vehicle, or near the tyres.
- When using the equipment, prevent it from getting rolled over by the vehicle, dropped, or trampled on.

WARNING

- Never drop the equipment or pull it directly by its cable. Take caution when moving the equipment.
- It is strictly prohibited to modify, disassemble, or repair the charging equipment and its ports.
- It is not recommended to use any additional wire or adapter/connector. If an additional adapter is required, choose a suitable cable diameter ($\geq 0.0023 \text{ in}^2$ or $\geq 1.5 \text{ mm}^2$) and the adapter/connector parameters must meet requirements.
- Never use the charging equipment if the household power strip cable becomes soft, if the charging connector cable is worn out, if the insulation layer is cracked, or in case of any other damage.
- Never use the equipment when the charging connector, power plug, or power strip is disconnected or broken, or if there is any sign of surface damage.
- To prevent failure of the charge port door, do not open and close it repeatedly. The recommended time interval for opening and closing the port door is at least one second.

CAUTION

- The charging cable must not be placed in a spiral during charging, as this will affect heat dissipation.
- See the charging instructions for specific charging precautions.

REMINDER

- It is recommended to contact a BYD authorised dealer or service provider or local electrician to select an appropriate power supply according to requirements of the charging equipment.
- Charging equipment grounding instructions: The equipment must be properly grounded. In the event of failure or damage to the equipment, the grounding cable provides a minimum impedance to circuit discharge and thereby reducing the risk of electric shock.
- The power plug must match a properly installed and well-grounded power supply outlet.

2. Charging

- With the vehicle doors unlocked and preferably powered off, press the charge port door to open it.



- Open the charge port cap, and make sure that no obstacles exist between the head of the charging connector and the end of the charging socket.

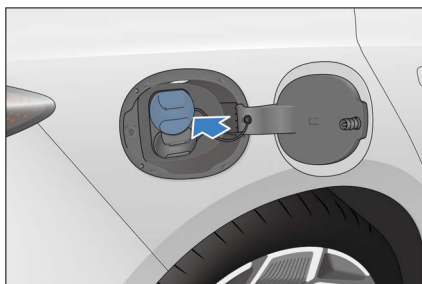

! REMINDER

- Do not open the charge port door forcibly when it is locked.
- If the charge port door is frozen due to weather or other reasons, it is suggested to warm it with hot water and then open the port, do not force it open.
- Connect the power supply terminal:
 - Plug the EV Mode 2 charging cable into a household socket.
- Connect the vehicle port:
 - Plug the charging connector correctly into the port.
- After the charging connector is inserted, the charging connection indicator  lights up on the instrument cluster.

! REMINDER

- Do not forcibly insert the connector with the electric lock engaged.
- In the charging process, charging parameters and the charging sign are displayed on the instrument cluster.
 - At this point, you can schedule charging on the infotainment system. See "Reservation Charging" for the setup process.

! REMINDER

- During charging, the estimated remaining time to full charge is displayed on the instrument cluster or infotainment touchscreen. It is normal that the remaining time to full charge may vary slightly, depending on the temperatures, SOC, and charging facilities.
- Reservation charging cannot be used when the battery is too low.

3. Stopping charging

- End the charging:
 - The charging automatically ends when the vehicle is fully charged.
 - Press the unlock button on the smart key or press the door handle microswitch (when the key is nearby), the vehicle will stop charging.*
- Unplug the charging connector:
 - If the anti-theft lock is deactivated, press the mechanical button of the charging connector or pull out the charging connector as needed.
 - If the anti-theft lock is activated, press the unlock button on the key or press the door handle microswitch (when the key is nearby), then pull out the charging connector.

! REMINDER

- To unlock the vehicle, press the unlock button on the key (when charging the vehicle with ignition off) or press the microswitch on the door handle (when the key is nearby).

! REMINDER

- When anti-theft is enabled, unlock the vehicle to release electrical lock of the charge port before pulling out the charging connector. The connector has to be pulled out within 30 seconds, or the port will relock.
- You can activate the anti-theft lock on the infotainment touchscreen, as detailed in "Charge Port Anti-theft Lock" in this chapter.
- If the charging connector cannot be removed after unlocking, try a few more unlocking attempts. If that does not work, try the emergency unlocking. For the operating procedure, see "Emergency Unlocking of the Charge Port" in "Charge Port Anti-theft Lock".
- When the charge port's anti-theft mode is deactivated, if you cannot pull the charging connector out directly, try to unlock the vehicle and pull it again.

- Disconnect the power plug.
- Close the charge port cap and the port door.
- Store the charging equipment properly.

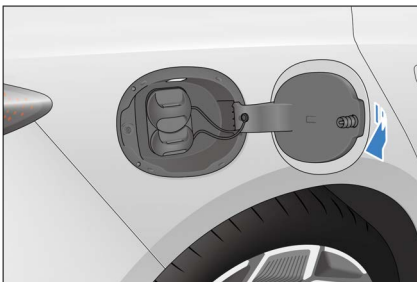

! REMINDER

- Do not close the charge port door when the port cap is fully open.

! WARNING

- Never drop the EV Mode 2 charging cable or pull it directly by its cable. Take caution when moving the equipment. Store the equipment in a cool place after use.

Charging with AC Charging Piles*

1. Equipment descriptions

- AC charging box
 - Use a standard-compliant household charging box. For how to use the charging equipment, refer to its user manual and follow the operating steps.
 - AC charging box: Consists of a charging box, a charging connector, and a connecting cable. For information on circuit breaker and emergency stop switch, see the charging box user manual.
- AC charging pile
 - Charge the vehicle using an AC charging pile in a public place.
 - Charging time: Refer to the charging time message on the instrument cluster or infotainment system.

2. Charging

- Unlock the vehicle and open the charge port door:
 - Close the charge port cap and the port door (see instructions for Mode 2 charging).
- Connect the vehicle port:

- Plug the charging connector into the port and make sure it is tight.
- Charging settings:
 - For AC charging pile/box subject to authentication, swipe the card or scan the QR code. See the user manual for charging pile/box for details.
- The charging connection indicator  lights up on the instrument cluster.
- In the charging process, the instrument cluster displays relevant charging parameters and the charging sign.
 - At this point, you can schedule charging on the infotainment touchscreen. See "Reservation Charging" for the configuration process.

3. Stopping charging

- End the charging:
 - Charging ends automatically when early stop time is due or charging is complete.
 - Press the unlock button on the smart key or press the door handle microswitch while carrying the smart key, the vehicle will stop charging.
- Unplug the charging connector:
 - Disconnect as per the instructions for mode 2 charging.
 - Close the charge port cap and the port door (see "Using Mode 2 Charging Cable").
- Store the equipment properly.
 - If an AC charging pile/box is used, place the charging connector in its designated location in the charging pile/box.

Using DC Chargers*

1. Equipment descriptions

- Use the DC battery charger in public places to charge the vehicle. Generally, it is installed in a specific charging station.
- Equipment specifications: Please check the instructions for the charger.
- Charging time: Refer to the charging time message on the instrument cluster or infotainment touchscreen.

2. Charging

DC charging is achieved by connecting the vehicle to a DC charger via its connector.

- Unlock the charge port door, then open the port door and cap.
- Connect the vehicle port:
 - Plug the connector into the port, making sure it is tight.
- Operate the charging equipment to start charging.

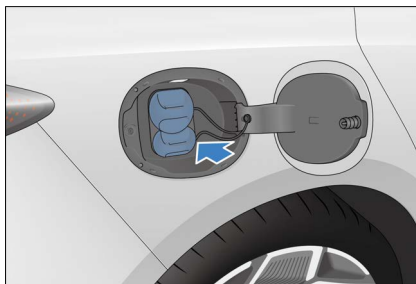

- The charging connection indicator  on the instrument cluster lights up.
- In the charging process, the instrument cluster or infotainment touchscreen displays relevant charging parameters and the charging sign.

3. Stopping charging

- End the charging:

- Charging ends automatically when early stop time is due or the charging is complete.
- Press the unlock button twice within three seconds or press the microswitch on the door handle to stop charging.*
- Disconnect the charge port:
 - Press the unlock button on the smart key or press the door handle microswitch while carrying the smart key and pull out the charging connector.
- When the DC charging pile charging is complete, organise the charging equipment and store the charging connector in its designated position properly.
- Reinsert the DC charge port cap and close the port door.

! REMINDER

- Do not close the charge port door when the port cap is fully open.



! CAUTION

- If the charging connector cannot be removed after unlocking, try a few more unlocking attempts. If that does not work, try emergency unlocking. For the operating procedure, see "Emergency Unlocking of the Charge Port" in "Electric Lock Control of the Charge Port".
- To unlock the charge port after DC charging, press the unlock button twice within three seconds for the operation to be successful.
- See the charging instructions for specific charging precautions.

! WARNING

- See section "Charging Instructions" for charging safety warnings.

Reservation Charging (Only AC)

- The charging mode can be set on the infotainment system. To access the setting:
 - Tap infotainment touchscreen →  → **New Energy** → **Reservation charging**.
 - To enter the setting page, say "Hi BYD, start reservation charging", "Hi BYD, I want to make reservation charging" or "Hi BYD, please help me start reservation charging".
- Exit the Reservation Charging screen by tapping the Back  /Home  button or by voice assistant:
 - To exit the page, say "Hi BYD, end reservation charging" or "Hi BYD, exit reservation charging".

Setting screen

- ① Reservation charging switch
- ② Charging start and end time
- ③ Repeat cycle
- ④ Settings



- The factory default setting is to charge the vehicle immediately. That is, reservation charging is disabled.

- To schedule a charging, tap the Reservation charging On button①, set the charging start and end time② and repeat cycle③, and tap "OK" to save the settings.
- After the reservation is set up successfully, if you connect the charging connector or press the power button to power off the vehicle during the charge waiting period, you will be reminded through the infotainment touchscreen that reservation charging has been set. Switch to instant charging if needed.
- You can tap the Smart Charging setting icon④ to turn off the charging connector connected alert and power-off alert in the Reservation charging.

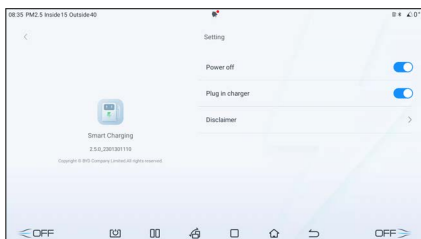

! REMINDER

- The instant charging option on the reminder screen is valid for the current reservation only. To cancel all reservations, turn charging reservation off on the reservation setting screen.
- The reservation charging function is dedicated for AC charging piles provided by BYD. If you need to use this function via a public charging facility, please make sure that the facility supports vehicle-terminal reservation.
- In the event of low battery, the vehicle is charged to the minimum level before scheduled

! REMINDER

charging begins. In this process, the infotainment system still gives reminder messages for power-off and charging connector connection, and a related message is displayed at the lower part of the instrument cluster.

- When connecting the DC charging connector, the schedule setting is invalid, and the vehicle will go into immediate charging.

! CAUTION

- The scheduled charging function is only developed for slow AC charging equipment supplied by BYD. Please disable this function when using slow AC charging equipment that is not certified by BYD. Otherwise, scheduled or immediate charging may fail due to no response from the equipment, resulting in insufficient battery power or even lack of electricity.

Intelligent Charging

- When the high-voltage battery is sufficient and the low-voltage battery is tested low by the system, the high-voltage battery would be actively triggered and charge the low-voltage battery.

! REMINDER

- When the vehicle is stored for a long time, the intelligent charging function may be activated and the engine compartment fan may be activated, which is normal.



REMINDER

- Power for intelligent charging comes from the high-voltage battery pack, so it is normal that an SOC decrease is noticed when the vehicle is powered on.

Discharging Device

- This vehicle features a vehicle to load (V2L) function.



WARNING

- Do not touch any metal terminal of the discharging socket or vehicle charge port during discharging.
- Stop discharging immediately if there are any abnormalities such as odour and smoke.
- See "Charging Instructions" for charging safety warnings.
- Store the product in a cool and dry place when it is not in use.
- When discharging, do not place the device in the boot, under the front of the vehicle, or near the tyres.
- When using the device, prevent it from getting rolled over by the vehicle, dropped, or trampled on.
- Never drop the device or move it by pulling it directly by the cable. Take caution when moving the device.
- Never use the charging device if the power strip cable becomes soft, the charging connector cable is worn out, the insulation layer is cracked, or any other damage occurs.



WARNING

- Never use the device when the discharging connector or power strip is disconnected or broken, or when there is any sign of surface damage.



CAUTION

- Avoiding damage to the charging equipment (precautions for charging equipment):
 - Prevent the charging equipment from suffering any mechanical impact.
 - Do not place the charging equipment near heaters or other heat sources.
- Before discharging, please confirm the vehicle SOC and estimate the remaining driving range.
- Before activating Vehicle to Load (VTOL), make sure the external load is off.



REMINDER

- The VTOL function is recommended only when SOC is high.
- The VTOL function is restricted when the vehicle SOC is low.
- The static power consumption of the vehicle will increase when the vehicle is powered off and the VTOL connection device is connected for an extended period without any output. It is recommended to remove the discharging/charging connector when the device is not used.

External Discharging Method

Discharging

- Before discharging, turn off the anti-theft mode of the vehicle.
- Unlock the charge port door, then open the port door and cap.
- Check before discharging:
 1. Ensure that the battery capacity of the vehicle to be discharged is not below 15%.
 2. Ensure the VTOL connecting device casing is not cracked, and its plug is free from rust or obstructions.
 3. Ensure that there is no water or foreign material inside the charge port and that metal terminals are not damaged and free from rust or corrosion.
- Do not discharge if any of the above conditions is found; otherwise, short circuit or electric shock so caused could lead to personal injury.
- Connect the discharge connection device:
 - Connect the VTOL discharging connector to the charge port and confirm that it is connected in place.
- After the switch button* on the discharging socket is pressed, the socket indicator stays on (red), indicating that the socket can be used.
- Discharging starts:
 - After the connection is made, discharge begins and respective information is displayed on the instrument cluster.

Stopping discharging

- Stop discharging:
 - Disconnect the load.

- Disconnect the discharge connection device:
 - Press the mechanical button on the discharging connector and remove the connector from the charge port.
 - Close the charge port cap and the port door (see **P82**).
- Organizing the equipment:
 - Store the equipment properly when discharging is complete.

Charge Port Anti-theft Lock

- In order to prevent the charging connector from being stolen, the vehicle charge port is anti-theft during charging and discharging. The anti-theft function is deactivated by default. To enable the function, go to the infotainment touchscreen →  → **New Energy** → **Charging Settings** and then tap **Activate**.
- Enter "Charging port anti-theft lock" and tap "Activate" or "Deactivate".
- When the anti-theft mode of charge port electric lock is activated, the charging connector will lock if the user connects the charging connector and the four doors, bonnet and boot lid are locked. To disconnect the connector, the user needs to unlock the vehicle.

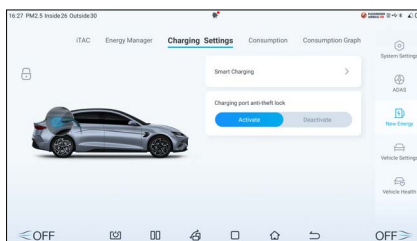

Unlocking

- When the function is activated, unlock the vehicle and unplug the charging connector during charging in the following ways:
- When it is on OFF status, press the unlock button on the smart key to unlock.

- Press the microswitch next to the exterior handle of the driver's side door to unlock.
- Press the central locking button under the driver's window to unlock.

No.	Charge Port Anti-theft Lock Status	Vehicle Door Anti-theft Lock Status	Charging Connector Removable or Not
1	Activate	Locking	No
2	Activate	Unlocking	Yes
3	Deactivate	Locking	Yes
4	Deactivate	Unlocking	Yes

WARNING

- The connector needs to be pulled out within 30 seconds after it is unlocked. Otherwise, the electric lock will lock again.

Emergency Unlocking of the Charge Port

- When charging connector cannot be unplugged due to failure of the anti-theft lock, unlock the charge port manually.

Charge port anti-theft lock

1. Open the boot, there is an emergency cable for the charging connector on the right side panel inside the boot.
2. Unlock the charging connector by unlocking the emergency cable latch and pulling the emergency cable.
3. Reset the emergency cable latch after the unlocking is complete.

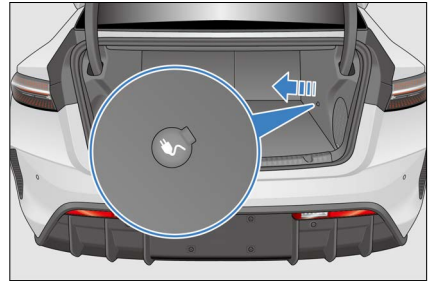

REMINDER

- If the above functions are abnormal or fail, contact a BYD authorised dealer or service provider.

Driving Range Display

The "Driving Range Display Mode" can be set to improve driving experience. The default setting is "Standard". You can personalise it by Infotainment touchscreen  → New energy → Energy management.

- Standard mode: displays the driving range based on the result of comprehensive working condition test.

- Dynamic mode: displays the estimated driving range based on the available battery power and current average energy consumption.
- The set driving range display mode is memorized by the system. When the vehicle is powered off and then on, the display mode set last time will be maintained.

REMINDER

- Driving Range Display Mode Settings:
 - The driving range that is displayed after a full charge may vary, depending on calculations of the energy consumed the last time the vehicle is used.
 - The displayed driving range is adjusted based on whether the A/C is on, selection of driving mode, and the driver's driving habits, so that this range can be closer to the estimated remaining range under current use.

Energy Regeneration Settings

Energy regeneration: In this process, the motor will generate reverse torque when the vehicle is decelerating, and the generated energy will be recovered and reused to improve the energy utilisation rate of the vehicle.

- Brakes regeneration:
 - When the vehicle is running in D position, if you completely release the accelerator pedal and depress the brake pedal, and the vehicle is in a stable state, priority is given to responding to motor regeneration for deceleration during braking

and deceleration. When the motor capacity is insufficient, the hydraulic brake will actively intervene to maintain the deceleration demand of the vehicle, and the generated energy will be recovered to improve the vehicle economy.

- Sliding recycling:
 - When the vehicle is running in D position, if you release the accelerator pedal below a certain depth, the motor will output reverse torque to decelerate the vehicle, and the generated energy will be recovered to improve the vehicle economy.
- During the driving, energy is recovered through regenerative brakes when the vehicle decelerates. For higher efficiency, do not accelerate or decelerate the vehicle unnecessarily.
- The energy feedback intensity can be set with the energy feedback mode button or on the infotainment touchscreen.
 - Standard: When the accelerator pedal is released, the motor controller recovers energy in the standard level, and the vehicle deceleration is in the standard level.
 - High: When the accelerator pedal is released, the motor controller recovers more energy, and the vehicle deceleration is high.
- The corresponding settings can be made on the infotainment touchscreen →  → **New Energy** → **Energy Manager** → **Energy feedback intensity**.
- You can select the regeneration intensity based on the deceleration sense when releasing the accelerator pedal. Different deceleration senses deliver different driving experiences.

- The set energy regeneration intensity will be memorised. When the vehicle is powered off and then on, the regenerative braking mode set last time will be maintained.

REMINDER

- Do not set the regeneration intensity when driving, as this may distract the driver's attention, causing an accident.

Battery

High-Voltage Battery

- The vehicle is powered by a high-voltage battery that can be charged and discharged repeatedly. The high-voltage battery is charged by an external power source or through energy recovery when the vehicle brakes or coasts.
- The high-voltage battery is located under the vehicle floor, so be careful and slow down to avoid bumping when driving on bumpy or uneven roads. If bumping occurs, go to a BYD authorised dealer or service provider for maintenance.

Battery Properties

- It is normal that vehicle performance is affected by battery electrochemical properties and self-protection and varies to some extent in the following conditions:
 - When SOC is high, the regenerative braking performance may decline.
 - The vehicle switches to trickle charging mode at high SOC. If the charging time is prolonged, the estimated remaining charging time

displayed on the instrument cluster may not be accurate.

- When SOC is low, the acceleration performance may decline.
- When the high-voltage battery is low, VTOL* cannot be used as normal. Charge the battery promptly.
- At high or low temperatures, it is normal that the charging and discharging capabilities of the high-voltage battery decline, and the charging time is prolonged. Power performance may also decline under extreme temperatures.
- When charging in low temperatures, the temperature control system can significantly improve charging capability. See Charging Precautions for details.
- When the vehicle is used at low temperatures, the battery's temperature control system will start heating the battery as appropriate to ensure the driving power and discharging performance and improve your driving experience. When the vehicle is driven over short distances, heating may be ineffective, which increases power consumption and decreases driving range.
- When the high-voltage battery is normal, the driving range of the vehicle varies with the following factors:
 - Driving habit: For example, the range in frequent acceleration or deceleration is shorter than that at constant speeds, and the range is shorter when driving at high speeds than when at low speeds.
 - Road conditions: For example, the range driven in rough conditions or on long slopes is shorter than that in normal conditions and on even roads.

- Temperature: The driving range at low temperatures is shorter than that at ambient temperatures.
- Use of electric equipment: For example, the range driven with A/C on is shorter than that with A/C off.
- Usable capacity of the high-voltage battery is lower in cold weather and reduces as the temperature decreases. If the vehicle with high battery level is charged at low temperatures, the SOC may quickly jump to 100%.
- The available battery capacity decreases as the vehicle is used over time.

Battery Usage Tips

- It is recommended to use the vehicle at temperatures between 14°F (-10°C) to 104°F (40°C). When SOC is low, timely charge the vehicle to ensure enough driving range and good acceleration performance.
- To ensure long term performance, avoid driving in extreme temperatures for over 24 hours.
- In low ambient temperatures, if the vehicle must be stored for a long time, it can be placed in an underground garage or other warmer area to reduce loss of battery heat, maintaining vehicle performance.
- Frequent and sudden acceleration or deceleration should be avoided. Drive the vehicle on flat and dry roads. When necessary, turn off high-power equipment such as A/C or adjust the A/C temperature to reduce power consumption of such devices and increase the driving range.
- When the vehicle is used for the first time or after a long idle period, the SOC displayed on the instrument

cluster may not be correct. It is recommended to fully charge the vehicle first.

- It is recommended to fully charge the vehicle at a regular basis (at least once a week), and fully charge it from low battery (SOC <10%) once every three to six months.
- Under extreme working conditions (such as frequent sudden acceleration/ deceleration) that cause battery overheating, if the temperature of high-voltage battery is excessively high, it is normal for discharging capability to decrease gradually. If the battery temperature keeps rising, the fault warning light lights up on the instrument cluster. In that case, it is recommended to contact a BYD authorised dealer or service provider.
- When the battery SOC increases or decreases abnormally, it is recommended to contact a BYD authorised dealer or service provider for inspection.

WARNING

- In the event of an emergency or accident, be aware of the following warnings:
 - To avoid personal injury, do not touch the high-voltage battery directly.
 - Please contact a BYD authorised dealer or service provider as soon as possible.
 - If the high-voltage battery is damaged and leaking fluid, avoid any contact with the fluid. If it comes into contact with skin or eyes, rinse immediately with plenty of water, and seek immediate medical attention.

WARNING

- If the vehicle catches fire, use dedicated fire extinguishers instead of water-based fire extinguishers.

CAUTION

- To ensure safety of the high-voltage battery, stop the vehicle away from flammable and explosive materials, ignition sources and various hazardous chemicals.
- The available battery capacity decreases as the vehicle is used over time.
- Prolonged exposure to heat sources and direct sunlight will reduce high-voltage battery service life.
- When the vehicle is not to be operated for an extended period (over seven days), it is recommended that the battery SOC should be kept at 40%-60% to prolong its service life. When the vehicle is not to be operated for over three months, the high-voltage battery must be fully charged and then discharged to 40%-60% every three months. Otherwise, over-discharge may lead to battery performance degradation or even damage. Any vehicle fault or damage so caused will not be warranted.
- As the high-voltage battery is arranged at the bottom of the vehicle, careful driving is recommended in case of bumpy roads. If there is a collision with the high-voltage battery, contact a BYD authorised dealer or service provider immediately for maintenance.

CAUTION

- No one is allowed to enter the vehicle when the battery pack needs to be repaired.

Recycling the High-Voltage Battery

How to scrap an NEV:

1. Take the vehicle to the BYD recycling service provider that will assess the residual value of the high-voltage battery.
2. Take the assessed vehicle to the recycling organisation to disassemble the high-voltage battery.
3. Take the battery to the recycling service provider which will buy back the battery.

WARNING

- New energy car owners have the responsibility and obligation to hand over waste high-voltage batteries to the recycling service outlet. Anyone who hands over a used high-voltage battery to any other organisation or individual, or removes/disassembles a high-voltage battery without authorisation, shall be liable for any environmental pollution or safety incident so caused.

Low-Voltage Battery

The low-voltage battery is located under the rear left seat.

- Battery working modes include "Normal", "Sleep", "Ultra-low Power", "Low-Voltage Protection". The purpose is to protect the battery cell from damage. If the vehicle system is in good condition, the vehicle switches

between these modes automatically, having no effect on your use of the vehicle.

- To avoid low-voltage battery feed, the smart charging function will be actively triggered if conditions (bonnet closed, ignition "OFF", high-voltage battery discharging allowed, and low-voltage battery level lower than the design value) are met.
- When the smart charging function is triggered, the low-voltage battery is charged through the high-voltage battery. Therefore, it is normal that the SOC or the pure-electric driving range displayed on the cluster decreases, when the vehicle is started after being idle.
- If smart charging fails, the low-voltage battery may cut off the vehicle's power supply. If you find before use that the vehicle is not powered, try to activate the low-voltage battery by pressing the driver's door microswitch continuously, and immediately power on the vehicle to charge the low-voltage battery. It is recommended to charge it for more than one hour.

CAUTION

- The low-voltage battery contains relays. Thus, it is normal that relay operating sounds may be emitted from the battery.
- The low-voltage battery shall be charged with professional charging tools, and shall not be removed for recharging without permission.
- Do not jump-start the vehicle with another fuel vehicle, as this may damage the low-voltage battery.
- The low-voltage battery is a battery on low-voltage platform that is different from an ordinary

CAUTION

lead-acid battery. Please read the instructions for use in this manual in detail.

- The low-voltage battery has a built-in power manager. Do not disassemble or repair the battery without permission to avoid damaging the battery or causing personal injury.
- The low-voltage battery needs to communicate with the vehicle for normal use, so it is important to connect its connector and wiring harness correctly.

Usage Precautions

Break-in Period

- If the powertrain is hard to start or frequently stops turning, inspect the vehicle immediately.
- If the powertrain makes any abnormal sounds, stop the vehicle for inspection.
- If the powertrain has severe coolant and oil leakage, stop the vehicle for inspection.
- The powertrain needs break-in. This should preferably be done within the first 1,243 miles (2,000 km) in economic mode. Steady driving instead of high-speed driving is recommended. The following practices effectively prolong vehicle service life:
 - Avoid flooring the accelerator pedal when starting and driving the vehicle.
 - Do not maintain a high or low speed for too long.
 - Avoid speeding.

- Do not use the vehicle to tow other vehicles within the first 1,243 miles (2,000 km) of mileage.

Trailer Towing

- This vehicle is designed to carry passengers. Do not overload it or use it to tow other vehicles.
- Towing other vehicles has an adverse impact on the maneuverability, performance, braking, endurance, driving economy, power consumption, and other aspects of performance of the vehicle itself.
- Driving safety and comfort totally depend on equipment usage and good driving habits.
- BYD does not provide free warranty for the damage or faults resulted from the trailer towing.

REMINDER

- Do not tow a trailer whose weight exceeds the tow eye capacity. Otherwise, it may cause an accident, resulting in serious personal injury.
- Be sure to increase the distance between the vehicle and another ahead of it when towing a trailer as the braking distance may be increased in towing. When driving at 6 mph (10 km/h), keep this distance at least equal to the sum of the length of the vehicle and the trailer. Avoid emergency braking to prevent vehicle folding and out of control due to slippage.
- Maintain the trailer's tyre pressure at the value specified by the trailer manufacturer based on the gross weight of the trailer.

REMINDER

- If the vehicle is used to tow a trailer, improve the maintenance frequency due to vehicle load increase.

Driving Safety Precautions

No Drunk Driving

Even a small amount of alcohol can reduce a driver's ability to respond to traffic condition changes. The higher the level of alcohol, the less responsive the driver will be. Therefore, never drive while under the influence.

No Speeding

Speeding is a major cause of collisions involving injury and death. In general, faster speeds entail higher risk. Therefore, please maintain a driving speed safe for the traffic conditions on the road.

Keeping the Vehicle Safe for Driving

Tyre bursts and mechanical faults are extremely dangerous. To reduce the possibility of such faults, frequently check the vehicle's condition, and regularly complete the specified inspections.

CAUTION

- Any driver must possess a driver's license before driving a vehicle.
- Do not drive when fatigued.
- Always follow the traffic regulations when driving a vehicle.
- When driving, drivers must stay focused and not carry out any unrelated activity, such as



CAUTION

answering calls or adjusting buttons.

Suggestions for Vehicle Use

Suggestions for prolong the battery usage:

- When the vehicle is not to be operated for an extended period (over seven days), it is recommended that the battery SOC should be kept at 40%-60%, or it will reduce high-voltage battery service life.
- When the vehicle is not to be operated for over three months, the high-voltage battery must be fully charged and then discharged to 40%-60%. Otherwise, over-discharge may lead to battery performance degradation or even damage. Any vehicle fault or damage so caused will not be warranted.
- During operation of the vehicle, if the instrument cluster displays the pure electric driving mileage as 0, it indicates the battery SOC is low. In this case, charge the high-voltage battery in time and avoid operating the vehicle with low SOC for a long time.
- For optimal battery performance, use a charging connector to fully charge the battery regularly, and the recommended frequency is once a week at least.
- To maintain long-term performance, avoid continuously exposing the vehicle to an environment with a temperature above 140°F (60°C) or below -22°F (-30°C) for over 24 hours.
- If the tray dented inward or there is scarification under the battery package

tray, it is suggested to check at a BYD authorised dealer or service provider.

- During operation of the vehicle, avoid repeated rapid acceleration or deceleration whenever possible.
- During operation of the vehicle, avoid operating the vehicle continuously for a long time whenever possible; otherwise, the excessively high battery temperature will affect vehicle performance.
- If the instrument cluster malfunctions when driving, it is recommended to contact a BYD authorised dealer or service provider for inspection as soon as possible.
- When the high-voltage battery temperature is high, the vehicle performance will be limited to some extent. In this case, stop the vehicle and wait until the temperature drops before operating.



REMINDER

- If the meter drops to 0, the battery must be recharged. If it is not recharged within seven days, the battery may suffer permanent damage. Such damage is not covered by BYD warranty terms.
- Driving range depends on many factors, such as the vehicle's available power, vehicle age (current battery life), weather, temperature, road conditions and driving habits. Compared with under normal temperatures, the pure-electric driving range is somewhat reduced and power performance will also be affected in low or high temperature environments.

Saving Energy and Extending Vehicle Service Life

- Saving energy is simple and easy, and it helps prolong the vehicle's service life.
- Energy and repair cost saving tips:

1. Regenerative braking setting:

- The vehicle is provided with an energy recovery function. To set the energy recovery intensity, go to infotainment

touchscreen →  → **Vehicle**

Settings → **Energy Manager**. In high energy recovery mode, more energy is recovered during vehicle braking and coasting. Please set to suit to your driving habits.

2. Maintaining constant speed:

- Constant speeds save energy. Sudden acceleration, sharp turns and emergency braking increase consumption.
- Speeds should be kept constant according to traffic conditions. Additional energy is consumed each time the accelerator is pushed.
- Acceleration should be gradual. Avoid sudden startup, acceleration, or deceleration.
- Prevent emergency braking and subsequent brake wear by keeping an appropriate distance from vehicles ahead, and paying attention to traffic lights.
- Congested roads increase energy consumption.
- Keep moderate speeds in motorways. The higher the speed, the higher the consumption. Maintaining vehicle

speed within the economical speed range can save power.

3. Reduce load:

- Energy consumption is higher when air conditioning is used. Turn off the A/C to reduce power consumption. When outside temperatures are moderate, use fresh air mode.
- Do not overload the vehicle unnecessarily. Excessive weights will add the load of vehicle, increasing energy consumption.

4. Other tips:

- Make sure tyre pressure is correct. Low tyre pressure increases energy consumption and wear.
- Keep front wheels properly aligned, avoid driving into kerbstones, and drive slowly in rough terrain. Misalignment of the front wheels not only increases tyre wear, but also increases load on the powertrain and power consumption.
- Keep the bottom of the vehicle clean and mud free. This reduces vehicle weight and prevents corrosion.

WARNING

- Do not coast in neutral gear.

Carrying Luggage

- This vehicle has multiple storage spaces. Overloading or improper accommodation may affect maneuverability, stability and normal operation of the vehicle, and reduce its safety.
- The glove box, storage boxes on interior trim panels and seatback pockets are designed for small and light objects, while the boot for large and heavy objects.

- Make sure the vehicle's total load (vehicle + passengers + luggage) remains within the specified maximum weight.

WARNING

- Overloading and improper accommodation may affect stability and vehicle control, which may lead to accidents.
- Observe the maximum weight limit and other loading guidelines in this manual.
- Do not carry highly magnetic items, as they might interfere in the vehicle's operating functions.

Carrying Luggage in the Passenger Area

- All items that could be thrown inwards and thus injure occupants in case of a collision must be properly placed and secured.
- Do not place any objects on the inner side of rear windscreen. Otherwise, these objects will block the driver's line of sight and will be thrown here and there inside the vehicle in case of collision.
- Ensure that objects placed on the floor behind the front seat do not roll under the seat, so as to avoid affecting the driver's ability to control the pedals or normal seat adjustment. Do not stack items to a height taller than the front seats' seatbacks.
- Make sure the glove box is always closed while driving. If the glove box is open, the occupant's knees may be injured in case of a collision or an emergency stop.

REMINDER

- Do not pile up toys in the vehicle, as this may affect driving safety and present a hazard to the children, especially in case of emergency braking or collision.

Loading the Boot

- Place luggage evenly in the boot. Put heavier items at the bottom and as far in as possible.
- Secure items with ropes or straps so that they will not move while driving. Do not stack items to a height taller than seat backs.

Wading into Water

- Check water depth before driving into flooded areas, it must not exceed the vehicle's lower edge.
- If crossing a flooded area is necessary, turn off the air conditioner and keep acceleration steady to slowly cross over.

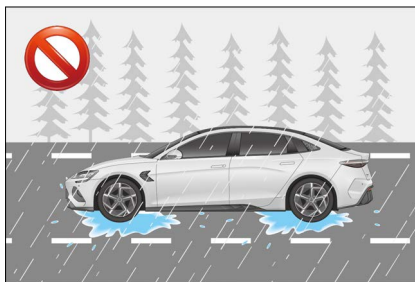

- Never stop, back up, or turn off the vehicle in flooded areas.
- Be careful when driving through deep water, as brakes may get wet. After crossing over, press the brake pedal several times to dry out the discs and recover brake performance.

WARNING

- Drive carefully to avoid accident when there is any water or slurry on the brake disc surface, as this may increase the brake response time thus extending the braking distance.
- Carefully apply any wet brake, and remove ice or water on it.
- Avoid emergency braking after driving through any waterlogged road section.
- If the vehicle drives on the waterlogged road, prevent water from entering the motor, or the motor will be damaged seriously. Such damaged is not covered by the vehicle's warranty
- Other systems like transmission, driving and electrical systems may also be seriously damaged upon submersion. Such damage is not covered by the vehicle's warranty either.
- Be sure to find a sheltered place when charging the vehicle on rainy days. If the vehicle is immersed in water or wades through water over the door sill, which may cause water ingress in high-voltage components, promptly contact a BYD authorised dealer or service provider for testing and troubleshooting.
- Do not drive on roads where the depth of accumulated water exceeds half of the tyres.

Influence of water ingress in high-voltage components:

- Water getting into high-voltage components, which are electronic

devices, may not be fully dried out by any means.

- Water ingress seriously compromises insulation of high-voltage components, and conductive substances in water may lead to short circuit of high-voltage components or such risk in the entire high-voltage system. In this case, the safety and service performance of the vehicle will be severely affected.
- The reduced ingress protection rating and voltage withstanding performance due to water in high-voltage components pose a high safety risk.

Fire Prevention

To prevent vehicle fires in a timely and effective manner, pay attention to the following during use of the vehicle:

- No flammable or explosive items are allowed in the vehicle.
 - Temperatures may reach 140-158°F (60-70°C) in a vehicle exposed to direct sunlight in summer. Therefore, flammable and explosive items, such as lighters, cleaning agents and perfumes, stored in the vehicle can cause a fire or even explosion easily.
- Make sure cigarettes are thoroughly put out.
 - Smoking is harmful to your health and may cause a fire. Cigarettes that not thoroughly put out may cause a fire.
- It is recommended to go to a BYD authorised dealer or service provider for regular vehicle checks.
 - Check vehicle wiring, connections, wiring harnesses, insulation, and fixed position regularly. Deal with identified problems promptly.

- Do not refit vehicle wiring or add any unauthorised electrical appliance.
 - The addition of extra electrical appliances, such as high-power audio systems, and light fixtures, may overload and overheat the wiring harness and increase the risk of fire.
 - Improper refitting of electrical appliances or wiring may cause a fire due to contact resistance and abnormal heating. Fuses or other replacement wires in excess of relevant electrical rating are strictly prohibited.
- Select a proper parking location.
 - Try to avoid sun exposure when parking the vehicle.
 - When the vehicle is parked, especially in summer, do check whether there are any flammables such as dry grasses, dead woods, leaves or wheat straws under the vehicle. If any, a fire may be caused.
 - When the vehicle is running, avoid driving on the road sections piled up with flammables such as dry leaves, wheat straws and grasses, or immediately stop the vehicle to check whether any flammables are carried along after passing such road sections.
- Keep a lightweight fire extinguisher in the vehicle and know how to use it.
 - In order to ensure vehicle safety, a fire extinguisher should be equipped in the vehicle, and be checked and replaced regularly. Also, you should familiarise yourself with use of the fire extinguisher and be prepared for any accidents.
- Disconnect the negative cable of the low-voltage battery when the vehicle is being serviced or repaired.
- In the event of a fire in the vehicle, take effective measures in a timely and calm manner to minimise any losses:
 - Fires typically show initial warning signs, such as abnormal noises and odours in the vehicle body. When abnormal conditions are found, turn off and stop the vehicle immediately. It is best to park the vehicle in a windproof place, and then put out the fire using the fire extinguisher in the vehicle.
 - Call the fire alarm in time, and also dial the insurance company's reporting number and ask the company to come to the fire site for handling.
 - Look for the ignition point. If the engine compartment smokes, do not open the bonnet immediately. (This will let a large amount of air in and cause fire spreading. There is limited comburent in the cabin. Keeping the bonnet closed can control the fire so that the fire can be easily put out). Point the on-board fire extinguisher at the ignition point from the bonnet gap to put the fire out, or seek help from the passing cars. If you can borrow more fire extinguishers, open the bonnet to put it out when you cannot see any flame from outside.
 - If the fire brigade is involved, ask for a duty performance certificate and a description of fire cause.
 - After occurrence of the accident, contact the insurance company for post-event handling in a timely manner.



REMINDER

- In order to mitigate losses in the event of an accident, the purchase of commercial insurance (fire loss, theft, etc.) is recommended.

Snow Chains

- Snow chains are only for emergencies or areas where they are permitted by laws.
- Snow chains should be installed on rear wheels. Be careful when driving the vehicle installed with snow chains on snow-covered roads. Use thin snow chains that provide enough space for the tyres and other parts in the hubcap, for some snow chains may damage tyres, wheels, suspensions, and the vehicle body.
- Read the component assembly drawings and other instructions provided by the snow chain manufacturer carefully.
- Before purchasing and installing snow chains, consult a BYD authorised dealer or service provider where your vehicle was purchased.
- After snow chains are installed, be sure to travel at a speed below 19 mph (30 km/h) on snow-covered roads.
- In order to minimise wear of tyres and snow chains, do not travel with snow chains on roads without snow.

! REMINDER

- Driving speed must not exceed 19 mph (30 km/h) or the speed limit specified by the snow chain manufacturer.
- Drive carefully and pay attention to bumps, potholes and sharp turns that can cause the vehicle to bounce.
- For vehicles with snow chains, avoid sharp turns or braking with locked wheels, and slow down the vehicle before entering a curve to avoid accidents due to loss of control.

! REMINDER

- Tyres snow chains should be used symmetrically and remove immediately when not in use.

Starting and Driving

Starting the Vehicle

Preparations before Driving

- Check the surroundings before getting into the vehicle.
- Adjust seat position, seatback angle, cushion height, headrest height, and the steering wheel angle and height.
- Adjust interior rearview mirror and side mirrors.
- Close all doors.
- Fasten the seat belts.

Safety Check before Driving

It is advisable to carry out a safety check before driving long distance, which ensures your driving safety and enhances your driving experience. The vehicle can also be taken to a BYD authorised dealer or service provider for inspection.

Exterior

- Tyres: Check tyre pressure and carefully inspect tyres for any cut, damage, foreign material, anomaly, and excessive wear.
- Lug nuts: Ensure all nuts are fitted and tightened.
- Lighting: Make sure headlights, position lights, turn signals and all

other lights are working normally. Check headlight intensity.

Interior

- Seat belts: Check whether seat belts can be properly fastened. Verify that seat belts are not worn or scratched.
- Instrument cluster: Particularly, verify that maintenance indicator, instrument cluster lighting, and defroster work properly.
- Brake pedal: Verify that there is enough space for the brake pedal to work.
- Low-voltage battery and cables: Inspect connectors for any corrosion or looseness and any cracks in low-voltage battery housing under the left rear seat.

In the engine compartment

- Spare fuses: Verify that spare fuses of all rated charges in the fuse box are available.
- Coolant level: Verify that coolant level is correct.

Check after starting

- Instrument cluster: Confirm that the maintenance indicator and the speedometer work normally.
- Brakes: In a safe area, drive the vehicle straight, hold the steering wheel tightly, decelerate and apply the brake. Verify that the vehicle maintains a straight direction.
- Other abnormalities: Check for loose parts, leaks, and unusual noises.

If everything is OK, just enjoy your driving.

Starting the Vehicle

In normal cases, start the vehicle as below:

- Carry a valid smart key with you, depress the brake pedal ② and press the START/STOP button ① at the same time, and then the OK indicator on the instrument cluster lights up, indicating that the vehicle is ready for driving.
- Shift to "D" or "R" position, and then the electrical parking brake will be released automatically. Do not start driving the vehicle until hearing a motor release sound from the electrical parking brake system.

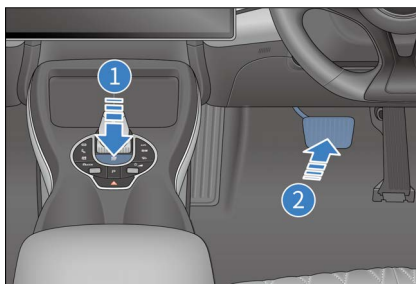

The vehicle cannot power on when

- The vehicle cannot power on when:
 - After pressing the START/STOP button, the smart key warning light turns on, a beep sounds, and the message "No key detected" is displayed on the instrument cluster. This means that the key is not in the vehicle or cannot be detected.
 - When the key is somewhere unsuitable for detection, such as on the floor, in the cup holder, boot or the right storage compartment, it cannot start the vehicle either.
- Pressing the START button may not enable the start function due to:
 - If the electronic smart key does not work, the smart key system warning indicator on the instrument cluster flashes, and the message "Low key battery" is displayed on the information display screen in the middle of the instrument cluster,

indicating that the key battery may have run out. Replace the electronic smart key battery as soon as possible with reference to the operation procedure given in "If the Smart Key Battery Is Exhausted".

- Except for causes mentioned above, the smart access and start system also fails to work normally under some conditions due to different service environments. Refer to "Smart Access and Start System" for relevant details.

Starting the vehicle in emergencies

- Engage the parking brake firmly.
- Turn off all the unnecessary lights and accessories.
- The gearshift lever is on "P".
- Switch the ignition off.
- The electronic smart key is in the vehicle.
- Press and hold the smart key start button for over 15 seconds.

Check After starting

- Instrument cluster: Confirm that the maintenance indicator and the speedometer work normally.
- Brakes: In a safe area, verify that the vehicle maintains a straight direction.
- Other abnormalities: Check for loose parts, leaks, and unusual noises.

If everything is OK, just enjoy your driving.

Remote Start

Remote Start with the Electronic Smart Key

1. Press and hold the remote start/stop button on the electronic smart key for two seconds to start the vehicle. After it is started, turn signals will flash three times.
2. If there is no valid operation within 10 minutes after remote start, the vehicle stops and powers off, and turn signals flash twice.



3. After the vehicle is started, pressing and holding the remote start/stop button on the smart key for two seconds switches the ignition off. The turn signals then flash twice.

Gear Shift Controls

- The gear position of the gear actuator is marked on the gearshift lever.
- "P" gear is for parking. Press this button to park the vehicle and the parking indicator will light up. Press the brake pedal when starting the vehicle, then the "P" gear can be switched to another position.

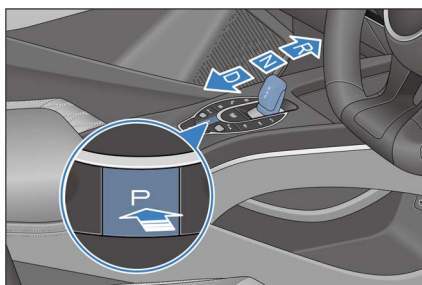

CAUTION

- To prevent damaging the transmission, press the "P" button only after the vehicle has completely stopped.
- "R": Reverse, used only when the vehicle has come to a complete stop.
- "N": Neutral, used for temporary stop. Under all circumstances, always shift to "P" before the driver gets out.
- "D": drive position. Shift to "D" position to drive the vehicle.
- If the shift is successful, the lever returns to its middle position after it is released.
- Before shifting into "D", ensure that the power switch is on "OK".
- Shifting out of "P" or into "D" gear requires pressing the brake pedal. For details, see the prompt message on the instrument cluster.

WARNING

- Transmission may be seriously damaged due to lack of lubrication if the vehicle is allowed to move for too long after the motor is turned off and "N" gear is engaged.
- When the motor is running and the vehicle is in the "R"/"D" gear, always stop the vehicle by

WARNING

stepping on the brake pedal, as there is still force transmitted from the actuator and the vehicle can travel slowly even in its idle condition.

- If you want to shift a gear while driving forward, do not step on the accelerator pedal to prevent accidents.
- Never shift to "R" or press the "P" button while the vehicle is moving, in order to prevent accidents.
- It is not recommended to allow the vehicle to go down a ramp when it is in the "N" or "P" gear, even if the vehicle is not started.
- To prevent inadvertent vehicle movement, apply the parking brake when the vehicle comes to a full stop and press the "P" button.



Electric Parking Brake (EPB)

Be sure to engage the EPB every time before parking and leaving the vehicle.

Engaging EPB manually

Set EPB on the "EPB" option on the infotainment touchscreen, when you press the brake pedal and EPB is released, EPB applies an appropriate parking force, the indicator on the instrument cluster flashes and then is steady on, indicating that EPB is engaged. In addition, a text prompt "EPB activated" is displayed.

 **CAUTION**

- When  flashes, EPB is working. If the vehicle is on a slope, do not release the brake pedal unless  is steady on. Otherwise the vehicle may move down.

Engaging EPB Automatically

Engaging EPB automatically when the ignition is switched off

- When the ignition is switched off, EPB engages automatically and  is displayed on the instrument cluster.

Shifting into "P" automatically

- Press the brake pedal to stop the vehicle and engage P gear. EPB is engaged automatically. Do not release the brake pedal until the indicator on the instrument cluster stops flashing and become steady on and the "EPB engaged" message is displayed.

 **CAUTION**

- After the trailer mode for EPB is enabled via the infotainment system, EPB will be not activated automatically when the vehicle is in "P" mode or powered off. This function may be used for towing or pushing the vehicle after the vehicle breaks down.
- Do not release the brake pedal early in the process, especially when the vehicle is stopped on a slope; otherwise there will be a risk of vehicle sliding to slight extent.
- This function is designed to improve the vehicle safety. Excessive reliance on or frequent use of the function is not recommended. For safety reasons,

 **CAUTION**

make sure that the vehicle is shifted into "P" or the EPB is engaged before getting off.

Automatic EPB Release upon Vehicle Start

- With the vehicle parked, start the vehicle, press and hold the brake pedal, and shift from "P" or "N" into a driving gear such as "D" or "R". EPB is released automatically, the indicator goes off, and a "EPB released" message is displayed.

 **CAUTION**

- The brake pedal must always be pressed when shifting gears. Release the pedal only after the intended gear is displayed on the cluster.
- Within several seconds after the vehicle is started, the EPB system will conduct self-check upon power-up. In this process, the EPB will not respond to any function.

- When the vehicle has been started and the gear is in a driving gear like "D" or "R", engage EPB manually, then simply press the accelerator pedal slowly to a certain degree. EPB is released automatically and  turns off with the message "EPB released" displayed.



Emergency Braking When Brake Pedal Fails

- If braking fails or is blocked, continue to press p gear switch or pull the EPB switch* for emergency braking.

CAUTION

- For safety considerations, refrain from using the EPB for braking in normal driving. If the brake pedal fails or is blocked, use the emergency braking function while you can always keep the vehicle under control and drive normally.

EPB System Indicator

- When the vehicle is powered on, if the EPB is engaged,  is solid on on the instrument cluster.
- When the vehicle is powered off, if the EPB is engaged,  comes on and then turns off in several seconds.
- When the vehicle is powered on, the EPB system starts self-check.  turns on and then turns off in about three seconds. If it does not, the EPB or braking system may be faulty. In this case, contact a BYD authorised dealer or service provider immediately.

EPB Operating Sound

- EPB motor noises can be heard while the EPB is being engaged or released.
- If there is a burning smell or unusual noises after emergency braking is activated, contact a BYD authorised dealer or service provider immediately.

WARNING

- To prevent the vehicle from moving, the gearshift is not to be used to replace EPB when parking. EPB must be used instead, and the vehicle must be in "P" gear.
- To prevent a serious accident, never allow any passenger in the

WARNING

- vehicle to operate the EPB switch when the vehicle is running.
- When the EPB switch is pulled or released, the brake pedal must be pressed to prevent the vehicle from moving, and the subsequent locking of the gearshift that occurs because EPB cannot provide a sufficient parking force.
- Avoid using EPB for braking in normal driving. It is preferred to be used when the brake pedal fails or is blocked.
- As the EPB cannot go beyond the physical limit of road adhesion, activating the emergency brake function may result in vehicle drift, sideslip or deflection when the vehicle passes through bends or dangerous/heavy-traffic road sections, or when the vehicle is driven under severe weather conditions. Be careful and do not cause any accident.

Automatic Vehicle Hold (AVH)

The automatic vehicle hold (AVH) takes place when the vehicle needs to be stationary for longer periods of time, such as in traffic jams on a slope or waiting at traffic lights. When the AVH standby preconditions are met, AVH is activated if you press the brake pedal until the vehicle stops.

- Press the AVH switch to enable AVH. A grey AVH standby indicator is displayed on the instrument cluster and will turn green when AVH can be enabled.
- Press the AVH switch again to disable AVH.

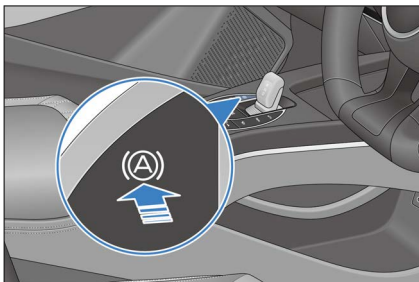

CAUTION

- Pressing the accelerator pedal, switching to the "P" gear, or engaging the EPB can make the vehicle exit AVH mode and return to the AVH standby status; even if the AVH standby status conditions are not met, the vehicle will also exit AVH mode.

Preconditions for AVH Standby (All Must Be Met)

- AVH switch is turned on and the white AVH standby indicator is displayed on the instrument cluster.
- The driver seat belt is fastened and the doors are closed.
- The vehicle drive motor is started or the ignition is on.
- Intelligent power braking and electronic park brake (EPB) systems are normal.

AVH Running Conditions (All Must Be Met)

- The AVH function is standby.
- In D gear, the brake pedal is pressed to stop the vehicle.
 - The AVH function is enabled, brake lights and the high mount brake light are on, and the AVH indicator on the instrument cluster turns green.

- The AVH function enters the standby mode after working for 10 minutes, with the EPB automatically engaged.

CAUTION

- For AVH to be activated, all the conditions must be met at the same time.
- For AVH to be activated, all conditions of automatic parking function must be met.
- When the gear is shifted from D to R, the system will enter the slow-moving condition, and the AVH function will not be activated. When the AVH button is pressed or the speed exceeds 6 mph (10 km/h), the system will exit the slow-moving mode.

Driving Precautions

- Slow down when driving against strong winds.
- Drive slowly and carefully along gravel roads and try to keep the correct angle. To prevent tyre damage, do not drive over sharp-edged obstacles. Or it will severely damage the tyres.
- Slow down on bumpy or uneven roads or the shock would damage the tyres.
- Avoid driving through flooded areas as much as possible.
- Drive carefully on slippery roads, such as roads covered in ice, snow or sand, or surfaces such as wet ceramic tiles or epoxy resin. Avoid parking on slopes to prevent vehicle sliding.

REMINDER

- The battery is located in the vehicle's chassis. Make sure to avoid bumping when driving.
- Before driving, make sure that EPB is fully released and that the EPB indicator light is off.
- Do not leave the vehicle when the drive motor is running.
- Do not put foot on the brake pedal when driving. Otherwise this will cause overheating, wear and waste of electric energy.
- Slow down when driving down steep slopes and avoid braking too frequently to prevent disc overheating, which affects brake performance.
- Be careful when accelerating or braking on slippery roads. Quick acceleration or sudden braking will cause the vehicle to skid or deviate.
- Make sure no occupant sticks their head or hands outside the vehicle, specially when it comes to children.
- Large amounts of water entering the engine compartment can cause damage to the power system and electrical components.

WARNING

- The driver shall ensure the riding safety of all passengers in the vehicle, guide them to correctly use vehicle features, and prevent children and other passengers from operating control switches

WARNING

such as window switches in a wrong way.

Winter Driving Precautions

- Make sure the coolant is freeze-proof.
 - Use coolant of the same type as the one used originally. Fill up coolant into the cooling system based on ambient temperature.
 - Improper coolant damages the cooling system.
- Check batteries and cables conditions.
 - The low-voltage battery's capacity is lower in cold weather, so they must be fully charged in winter.
- Avoid door frost.
 - Spray some deicing agent or glycerin in the lock hole to prevent freezing.
- Use anti-freeze washer fluid.
 - These can be found in the BYD authorised dealer or service provider and the auto parts stores.
 - The water and anti-freeze ratio must conform to manufacturer instructions.

CAUTION

- Do not use other substitutes as washing fluid, which may damage the vehicle paint.
- Prevent ice and snow from going under the fender.
 - Steering is difficult with ice or snow accumulating under the fenders. When driving in cold weather, stop from time to time and check for snow and ice under the fenders.

- Have emergency tools or items available as prevention for difficult road conditions.
- It is advisable to have snow chains, window scraper, bags of sand and salt, flashing signal, a shovel and connecting cables in the vehicle.



Driver Assistance

Adaptive Cruise Control (ACC)

- The adaptive cruise control (ACC) system, an extension of the traditional cruise control, uses a radar and a multi-purpose camera to detect the relative distance and speed of the vehicle ahead, so as to control vehicle speed accordingly. The system switches between regular cruise control and ACC according to whether there is a vehicle ahead.
- Cruise speed and time interval from the vehicle ahead can be set by using the cruise buttons. You can set the cruise control speed within the 30-150 km/h (20 to 95 mph) range, or set a fixed distance from the vehicle ahead to cruise at speeds between 0 km/h and 150 km/h (0 to 95 mph).

Status Description

- ACC standby:
 - Once enabled, the system is on standby by default and can be manually activated. If the vehicle does not meet activation conditions, it must be checked until such conditions are met. At this time,  is displayed on the instrument cluster. (The cruise speed value is variable.)

- ACC activated:
 - The system is operational. It maintains the set speed or automatically adjusts the distance from the vehicle ahead. At this time,  is displayed on the instrument cluster. (The cruise speed value is variable.)
- Over speed:
 - When you step the accelerator pedal while ACC is active, the vehicle responds to your acceleration action so that the ACC is temporarily deactivated until you release the pedal.
- ACC failure:
 - There has been a failure in the system. No operation can be performed, and the ACC failure indicator  is displayed on the instrument cluster. (The cruise speed value is variable.)

ACC Activation Conditions

- The EPB is released.
- The vehicle is in Drive.
- The vehicle does not slide backwards.
- The boot, bonnet and all doors are closed.
- Driver seat belt is fastened.
- The ESC system is on, but not activated yet.
- The vehicle speed is not greater than 150 km/h (95 mph).
- Brake pedal is pressed at speed 0; or brake pedal is not pressed at speeds above 0.

- There is no vehicle network communication failure prompt on the instrument cluster.
- The AEB function is not activated.

Cruise Button Operation

ACC on/off button

Press button ① to activate or exit ACC. (The system is on standby when activation conditions are met). (By default, ACC activation by pressing button ① sets the current speed as the cruise speed. If the current speed is below 18 mph (30 km/h), the cruise speed is set to 18 mph (30 km/h).)



Resetting ACC

When the ACC system is on standby within the same ignition cycle, the system memorises the last speed setting. Push up the lever ② to revert to the stored speed prior to exiting the cruise system.

Increasing/Decreasing target speed

When ACC is active, set the vehicle to a speed within the 19~93 mph (30~150 km/h) range by moving the lever ②. Toggling the lever ② up or down increases or decreases target speed by 3 mph (5 km/h).

Exiting ACC

While ACC is active, pressing button ① for a second time or pressing the brake pedal makes the ACC system go on standby.

WARNING

- Please strictly abide by the speed limit regulations of local roads, control the speed and drive safely. Do not speed.

Setting vehicle distance

- The driver must select a safe vehicle distance.
- The system adjusts vehicle speed to keep a suitable distance from the vehicle ahead on the same lane. Pressing buttons ④ and ⑤ on the steering wheel adjusts vehicle distance to any of the four available levels. At each level, vehicle distance is in direct proportion to vehicle speed. The faster the speed, the longer the distance.

Increasing/Decreasing speed with ACC active

- When ACC is activated, you can press the accelerator pedal to reach the set target cruise speed in advance. The system then enters over speed mode. At the target cruise speed, if you accelerate without performing any other operations, the vehicle accelerates and then returns to target cruise speed after the accelerator pedal is released.
- When you press the brake pedal with ACC activated to slow down the vehicle, ACC goes into standby mode. After the brake is released, ACC needs to be reactivated.

Follow-to-stop/start

- Controlled by ACC, the vehicle can stop when the vehicle ahead stops in normal driving conditions and resume driving automatically following the vehicle ahead if the stop is less than 30 seconds.
- If the vehicle stops for 30 seconds to three minutes, press the accelerator

pedal or pushing up lever② to reactivate ACC.

System Limitations

- The front mmWave radars are installed in the front of the vehicle. Blockage of its detection area by contaminants can disturb the intended function. In particular, if the sensor is covered by snow completely, the ACC system exits and informs of this on the instrument cluster. System function will recover after blockage is removed and the vehicle is restarted or runs on normal roads for a while.
- Front mmWave radar sensors may have a transient function failure from limited detection if the vehicle runs under special conditions, such as circular ramps or tunnels, for an extended period. The function can be recovered by restarting the vehicle or driving on normal roads for a while.
- Reaching or leaving a curve may delay or disturb the target selection. In such cases, the ACC vehicle may not brake as expected or may brake late.
- On roads with sharp curves, such as winding roads, the vehicle ahead may be out of ACC sensor detection for several seconds due to sensor vision limitations, possibly causing the ACC vehicle to accelerate automatically.
- Traffic flow and weather conditions, such as rain and fog, must be heeded for setting vehicle distance on the ACC system. After the ACC system is properly set, the driver must be able to decelerate until the vehicle stops at any time.
- The ACC system may not be able to identify stationary or slow-moving objects, such as vehicles, the end of traffic, toll booths, bicycles, or pedestrians. This means a risk of

collision and requires the driver to beware of the surroundings.

- The ACC system cannot identify pedestrians or oncoming vehicles.
- The ACC system can only achieve limited braking instead of the emergency braking.
- Metal objects, such as rail or metal plates used in road construction, may interfere with front mmWave radars, making it malfunction.
- Performance of front mmWave radar sensors may be affected by vibration or collision. In this case, it is recommended to contact a BYD authorised dealer or service provider.
- ICC cannot be activated in special driving modes like tow/snow/mud/sand/terrain (if equipped with).

Precautions

- ACC is a comfort system rather than a safety system, obstacle detector or collision warning system. The driver must keep control of the vehicle at all times and be fully responsible for the vehicle.
- ACC assists instead of replacing the role of the driver. The driver is responsible for abiding by traffic rules and keeping vehicle control.
- For safety reasons, ACC cannot be activated with ESC disabled.
- The ACC is suitable for motorways and roads in good conditions, rather than complex urban or meandering roads.
- It is the driver's responsibility to keep distance from the vehicle ahead. The ACC system's vehicle distance meets the minimum distance required in driving environments in the country.
- Vehicle control is transferred to the driver if the accelerator or brake pedal

is pressed with ACC active. As a result, the ACC system cannot keep a safe distance from the vehicle ahead.

- ACC may have no or slow responses to a vehicle ahead that brakes or stops suddenly, resulting in a risk of late braking. In such cases, there will be no take-over request.
- In some cases, such as when the vehicle ahead is going too slow, when lane change is too fast, or when the safe distance from the vehicle ahead is too short, there is no adequate time for the system to decrease the relative speed, so response has to come from the driver. The system cannot give audible or visual warnings in every case.
- If ACC is activated with the vehicle stationary, the system identifies any stationary obstacle ahead and keeps the vehicle still to ensure a safe startup and prevent collision. However, this function cannot identify all the obstacles, so the driver must be alert to the front obstacles or other traffic participants.
- A short distance from an adjacent lane (or a vehicle on an adjacent lane that is too close to the ACC vehicle's lane) may trigger ACC to brake.
- Vehicles coming into the ACC vehicle's lane and within the detection range of its front mmWave radars are identified as target vehicles and prompt a response accordingly, which may lead to hard or late braking.
- Detection may be affected or delayed in some environments. If the radar reflection cross-sectional area of the target (a bicycle, four-wheeler, or pedestrian, for example) is too small, the system may not be able to establish its distance, resulting in either late or no response to those vehicles. In such cases, vehicle speed

must be controlled by the driver. In addition, detection may also be affected or delayed by noise or electromagnetic interference.

- ACC cannot target vehicles with too small contact ratio, so the driver must keep control of the vehicle.
- When the vehicle stops as it follows a vehicle ahead, in rare cases, the system does not recognise the end of the vehicle ahead but the lower end of the target (for example, the rear axle of a truck with a high chassis or a vehicle bumper). In such cases, the system cannot ensure proper stop distance, so the driver must stay alert and be ready to brake.
- If ACC is activated with the vehicle stationary, the system identifies any stationary obstacle ahead and keeps the vehicle still to ensure a safe startup and prevent collision. However, this function cannot identify all the obstacles, so the driver must be alert to the front obstacles or other traffic participants.
- Changing the vehicle structure, such as lowering the chassis or changing the front license mounting plate, may affect the ACC system.
- Do not use the ACC system when visibility is poor, or when driving on slopes, winding roads or wet roads (covered in ice/snow or flooded).
- Make sure to go to a BYD authorised dealer or service provider for professional calibration and checking of front mmWave radars or the multi-purpose camera in any of the following situations:
 - The front mmWave radar, front bumper, or front windscreen has been removed.
 - Wheel alignment has been carried out.

- The vehicle has experienced a collision.
- ACC system performance has degraded or the instrument cluster has prompted a system error.

 **WARNING**

- ACC serves as a driver assistance function only, so the driver is fully responsible for driving safety.
- Influence of weather, road conditions, and other factors may cause ACC to fail.
- Use ACC based on your needs, traffic, and road conditions.



Intelligent Cruise Control (ICC)

- The intelligent cruise control (ICC) system integrates ACC and lane centring control (LCC). It helps control the vehicle both longitudinally and transversely at speeds between 0 mph and 74 mph (0~120 km/h) to reduce the driving burden and provide a safe and comfortable driving environment.
- When the function is enabled, the driver must always hold the steering wheel and control the vehicle when necessary.
- Longitudinal assistance, driven by the ACC system, keeps the vehicle at a fixed speed or a fixed distance from the road user ahead.

Status Description

- ICC standby: The ICC system is on standby by default and can be manually activated. If the vehicle does not meet activation conditions, the vehicle must be checked until such

conditions are met. At this time,  is displayed on the instrument cluster.

- ICC activated: The ICC system is operational. It maintains the set speed or automatically adjusts the distance from the vehicle ahead. At this time,  is displayed on the instrument cluster.
- ICC failure: There has been a failure in the system. No operation can be performed, and the ICC failure indicator  is displayed on the instrument cluster.

ICC Activation Conditions

- The EPB has been released.
- The vehicle is in Drive.
- The vehicle does not slide backwards.
- The boot, bonnet and all doors are closed.
- Driver seat belt is fastened.
- The ESC system is on, but not activated yet.
- Vehicle speed is not greater than 75 mph (120 km/h).
- Brake pedal is pressed at speed 0; or brake pedal is not pressed at speeds above 0.
- There is no vehicle network communication failure prompt on the instrument cluster.
- The AEB function is not activated.
- Two-way lane lines are clear and the vehicle is at the centre of the lane.

How to Use

- Press the button ③ on the steering wheel to activate or exit ICC. (By default, when the function is activated, the current speed is set as the cruise speed. If the current speed is less than 18 mph (30 km/h), the cruise speed is set to 18 mph (30 km/h)).
- For how to set the cruise speed and vehicle distance, see ACC function descriptions (in the previous chapter).



- You can also turn ICC on or off in Vehicle Settings  → ADAS → Intelligent Driving. When the vehicle is just started up, ICC status before the last power-off is maintained.

Precautions

- ICC integrates ACC and LCC. Therefore, ACC function precautions must be followed during use (see the previous chapters for details).
- When ICC is turned on and activated at vehicle speeds between 0-74 mph (0-120 km/h):
 - If there is no lane lines ahead, transverse ICC control is suppressed and only ACC works. In that case, ICC working status indicator turns grey on the instrument cluster.
 - If lane lines ahead are clear and recognizable, transverse ICC control is activated automatically. In that case, ICC working status indicator

shows activated status on the instrument cluster.

- The ICC system is a driving assistance system, not an automatic driving control of vehicle at all times, and their hands should not leave the steering wheel for a long time. Otherwise, the system will exit after prompting the driver to take over the control.
- The ICC system can be affected by weather conditions, lighting and clarity of lane lines. Performance degrades significantly in situations such as backlighting, sunset, snow covered roads, and severely damaged roads.
- Do not use the ICC system on winding roads with sharp turns, icy and slippery bends, or under weather conditions, such as dense fog, heavy rain and heavy snow, liable to hinder the sensing operation of front mmWave radars or the multi-purpose camera.
- Situations where ICC cannot be used:
 - The sensor is blocked.
 - The vehicle is running under severe weather conditions.
 - Active safety function is triggered.
 - Vehicle speed exceeds specified range.
- ICC cannot be activated in special driving modes like tow/snow/mud/sand/terrain (if equipped with).

WARNING

- ICC serves as a driver assistance function only, so the driver must be fully responsible for driving safety.





WARNING

- Influence of weather, road conditions, and other factors may cause ICC to fail.
- Use ICC based on your needs, traffic, and road conditions.

Predictive Collision Warning (PCW) & Automatic Emergency Braking (AEB)

Predictive collision warning (PCW) system and Automatic Emergency Braking (AEB) system detect vehicles and pedestrians ahead by using a radar and a multi-purpose camera. When detecting a risk of collision, the system gives audible and visual alarms to alert the driver and improves the potential braking pressure for better response timing. If detecting increased risk of collision, the system automatically applies braking pressure to assist in collision avoidance or impact reduction.

How to Use

- Enable or disable the PCW and AEB in **Vehicle Settings** →  → **ADAS** → **Active Safety**.
- PCW gives alarms in forms of audio, messages, and intermittent braking.
- When PCW is activated,  or  flashes, depending on the level of emergency, and a prompt message is displayed on the instrument cluster.
- When AEB is triggered,  and a prompt message are displayed on the instrument cluster.
- In the event of malfunction,  is displayed on the instrument cluster.

- If you disable AEB manually by pressing buttons,  is displayed on the instrument cluster.

PCW Activation Conditions

- This function has been turned on in **Vehicle Settings**.
- Vehicle speed is within the 10-93 mph (16-150 km/h) range.
- The vehicle is in Drive.
- The vehicle does not slide backwards.

AEB Activation Conditions

- This function has been turned on in **Vehicle Settings**.
- Vehicle speed is within the 3-93 mph (4-150 km/h) range.
- The EPB has been released.
- The vehicle is in Drive.
- The vehicle does not slide backwards.
- The boot, bonnet and all doors are closed.
- Driver seat belt is fastened.
- The ESC system is on, but not activated yet.

AEB Activation Scenarios

- Pedestrians
 - A pedestrian in front walking in the same direction as the vehicle
 - A pedestrian crossing in front of the path of the vehicle (including when the vehicle is turning or the driver's view is obstructed)
- Non-motor vehicles
 - A bicycle or motorcycle in front travelling at a low speed in the same direction as the vehicle

- A bicycle or motorcycle crossing in front of the path of the vehicle (including when the vehicle is turning or the driver's view is obstructed)
- A stationary motorcycle in front
- Motor vehicles
 - A stationary vehicle in front
 - A vehicle in front travelling at a low speed or decelerating in the same direction as the vehicle
 - A vehicle crossing in front of the path of the vehicle (including when the vehicle is turning)
 - A vehicle in front travelling in the opposite direction as the vehicle
 - A vehicle in front travelling in the opposite direction to attempt an overtake
- When the above scenarios are detected, the AEB system will determine in real time if a collision risk exists. If there is a risk of collision, AEB system will give alerts and initiate auto-braking to mitigate severity or avoid a collision.

System Limitations

- Detection may be affected or delayed in some environments. If the radar cross section of the target (a bicycle, three-wheelers, four-wheeler, or motorised bicycle, or motorcycle, for example) is too small, the system may not be able to establish its distance, resulting in either late or no response to those vehicles. In such cases, vehicle speed and distance must be controlled by the driver.
- The activation of the AEB system depends on various factors such as the environment, the state of the vehicle and the target. There is no guarantee that the emergency braking can always be activated in every scenario.

- The system may be affected or give no response in the following cases:
 - On rainy, snowy or foggy days, large water splashes, or exposure to direct sunlight or glaring lights, or significantly varying lighting conditions.
 - Dirty, hazy, damaged or blocked sensor.
 - Radar failure due to interference from other radar sources, such as strong radar reflection in multi-storey car park.
- In complex traffic, the system may be unable to properly respond to the following circumstances:
 - Pedestrians or vehicles move too quickly into the sensor's detection range.
 - Pedestrians are obscured by other objects.
 - Pedestrian outlines are indistinguishable from the surroundings.
 - Pedestrians are not detected, due to, for example, coverage by special clothing or other materials.
- The vehicle is on a sharp curve.

Precautions

- The AEB system cannot ensure zero collision. In complex traffic, the system cannot always clearly identify all the vehicles or pedestrians. It may trigger unnecessary warning or braking action for well covers, iron plates or road signs.
- Make sure to drive safely and observe surrounding traffic conditions. The AEB system is not a substitute for normal braking operation in any event.

- Do not overly rely on the AEB system as this may result in severe injuries or deaths. The system is only an auxiliary safety tool. The driver must always keep a safe distance from vehicles ahead, control the speed, and be ready to brake or steer away when necessary. The driver must keep control of the vehicle at all times and be fully responsible for safe driving.
- The AEB system is activated only when it exceeds certain speeds. Careful driving is always required, because the system may not be triggered correctly.
- The AEB system cannot work normally when the ESC function is disabled or the fault light is on.
- If PCW gives an alarm, the driver must brake based on traffic conditions to decrease vehicle speed or steer away from obstacles.
- If the vehicle travels too close to the vehicle ahead for too long, a safety distance warning will be given. If the vehicle ahead brakes suddenly, collision may be unavoidable.
- The system will not trigger AEB when the driver is aware of an emergency warning but turns the steering wheel, accelerates, or brakes.
- Front mmWave radar sensors may have a transient function failure from limited detection if the vehicle runs under special conditions, such as circular ramps or tunnels, for an extended period. The function can be recovered by restarting the vehicle or driving on normal roads for a while.
- Sometimes the front mmWave radar or multi-purpose camera detect dirt or foreign matter on its surface, then PCW and AEB would malfunction, you need to clean the dirt or foreign matter immediately.
- As the pedestrian protection function is limited by certain physical conditions, the driver must take timely and effective control of the vehicle under dangerous conditions.
- The system cannot completely protect pedestrians or avoid accidents and severe injuries on its own.
- Under certain complex conditions, the pedestrian protection function may trigger unnecessary warning or braking. For example, on the curving main lane.
- System failure may trigger wrong warnings or braking. This may be caused, for example, by the misalignment of the front mmWave radar or multi-purpose camera.
- The brake pedal becomes harder if AEB is triggered. A large amount of hydraulic pressure will be required to push the caliper in a short time and there will be a sizzling noise.
- The AEB system activates only after all doors are closed and all occupants are buckled up. Note: The AEB system will fail to work if:
 - Any door is not closed or it is opened when the vehicle is moving.
 - Any seat belt has not been fastened or it is unfastened while the vehicle is travelling.
 - The driver accelerates or decelerates rapidly or turns the steering wheel quickly.
 - The vehicle is on a sharp curve.
- System performance may be reduced in the following cases:
 - Strong front bumper impact from accidents or other causes.
 - Improperly inflated or worn out tyres.

- Unqualified tyres installed.
- Snow chains installed.
- Use of a small spare tyre or tyre repair kit.
- Make sure to go to a BYD authorised dealer or service provider for professional calibration of the front mmWave radar or multi-purpose camera in any of the following situations:
 - The front mmWave radar or multi-purpose camera has been removed.
 - Toe-in or rear camber has been adjusted during wheel alignment.
 - The position of front mmWave radars or the multi-purpose camera has changed after a collision.
- Do not attempt to test the AEB system on your own by using objects such as carton, iron plate, dummy, etc. The system may not work properly and thus result in accidents.

WARNING



- PCW and AEB serve as driver assistance functions only, so the driver is fully responsible for driving safety.
- Influence of weather, road conditions, and other factors may cause PCW and AEB to fail.
- Use PCW and AEB based on your needs, traffic, and road conditions.

Front Cross Traffic Alert (FCTA)/Front Cross Traffic Braking (FCTB)

Front cross traffic alert (FCTA) and Front Cross Traffic Braking(FCTB) detects

vehicles crossing the driveway at the front through mmWave radars on both sides of the front bumper to alert the driver and engage the brake if necessary. At low vehicle speeds, when the system detects a risk of collision with a vehicle crossing the driveway at the front, it provides the driver with visual and audible alerts; in the event of an impending collision, the vehicle brakes automatically.

How to Use

- To enable or disable the FCTA and FCTB, go to infotainment touchscreen → , and tap **ADAS** → **Active Safety**.
- When Front Cross Traffic Alert(FCTA) is activated, the rearview indicator flashes and a chime sounds.
- When FCTB is activated,  is shown on the instrument cluster with audible alarms, AEB will also be activated.
- In the event of FCTA/FCTB malfunction,  is displayed on the instrument cluster.

Precautions

- RCTB activation scenario:
 - A pedestrian or vehicle is crossing in front of the path of the vehicle that is moving at a low speed or turning.
- The activation of the FCTB system depends on various factors such as the environment, the state of the vehicle and the target. There is no guarantee that the emergency braking can always be activated in every scenario.
- While the system provides assistance in monitoring front left and right sides, it cannot replace the driver's observation and judgement. The driver must keep control of the vehicle at all times and drive properly and is fully responsible for the vehicle.

- When a target vehicle is approaching from the side at a high speed, the FCTA/FCTB system may not be able to provide adequate warning.
- The driver must ensure the normal operation of the system, keeping mmWave radars on both side of the bumper in good condition. For example, dirt, snow, or other obstructions need to be cleared right away.
- In addition, detection may also be affected or delayed by noise or electromagnetic interference.
- Under some circumstances, it is difficult for the system to assist the driver, and detection may be affected or delayed. Possible circumstances include, but are not limited to:
 - The vehicle coming from the side changes the lane suddenly.
 - The target vehicle is obscured.
 - The radar cross section of the target (for example, a bicycle or electric moped) is too small.
 - The vehicle is running under severe weather, such as rain or snow.
 - MmWave radar(s) come off, are loosely installed, or are blocked.
 - The vehicle encounters complex metal guardrails or similar road conditions.
- The system does not work when:
 - Targets are outside the mmWave radar's detection range.
 - FCTA or FCTB is switched off.
 - The vehicle is not in Drive.
 - Four doors are open.
 - System initialisation has not been complete yet.
- MmWave radars fail.
- Vehicles coming from the front left or right side are detected too late at sharp turns, slopes, or other settings.
- Influence of vibration or collision on mmWave radar sensor calibration can degrade the system performance. If this is detected, contact a BYD authorised dealer or service provider.



WARNING







- FCTA/FCTB serves as a driver assistance function only, so the driver must be fully responsible for driving safety.
- Influence of weather, road conditions, and other factors may cause FCTA/FCTB to fail or lead to late braking.
- Use FCTA/FCTB based on your needs, traffic, and road conditions.

Traffic Sign Recognition (TSR) System

The traffic sign recognition (TSR) system identifies speed limit signs through the multi-purpose camera and map*, displays such signs on the current road on the instrument cluster, and sends alarm messages to the driver when vehicle speed exceeds the detected limit.

How to Use

- To enable or disable TSR, go to infotainment touchscreen →  → ADAS → Driving Assist → TSR.
- When the TSR system identifies the current traffic sign,  is displayed on the instrument cluster.

- When TSR cannot identify whether the recognised speed limit values apply to the lane,  is displayed on the instrument cluster.
- When the TSR system experiences reduced performance,  is displayed on the instrument cluster.
- When the TSR system has a reduced performance and cannot identify whether the recognised speed limit values apply to the lane,  is displayed.
- If the TSR system malfunctions,  is displayed on the instrument cluster.
- If you disable TSR manually by pressing buttons,  is displayed on the instrument cluster.
- The specific numbers displayed in the indicators depend on the actual traffic signs.
- If you disable TSR manually by pressing buttons,  is displayed.

Precautions

- The TSR system can identify speed limit signs only, and will not control speed. The control over the vehicle always vests in the driver. Please drive properly.
- Weight limit signs not in standard size as per national regulations may mistakenly be identified as speed limit signs.
- If a speed limit sign is unclear, distorted, inclined, reflective, or partly blocked or overlaid, the multi-purpose camera may fail to or incorrectly identify the sign.
- TSR performance depends on weather conditions, lighting, and sign visibility.

The system may fail to or incorrectly identify the sign at night or sunset, in rainy, foggy, hazy, snowy or dusty environment, when light is coming from the back of the vehicle, or when there is a sudden change in lighting.

- In case the vehicle has been involved in a collision or the multi-purpose camera's sensor has been reassembled, go to a BYD authorised dealer or service provider for sensor calibration so as to avoid affecting system performance.
- If the model is available on the European market, recognition of traffic jams, construction zones, and accidents ahead must rely on Internet connection and is on the premise that recognition of these signs are supported. It is suggested to use this function when linking to Wi-Fi/hotspot. You can also open "TSR mobile data" which consumes vehicle traffic, if the used traffic reaches the monthly limit, the function is disabled.

WARNING

- TSR serves as a driver assistance function only, so the driver must be fully responsible for driving safety.
- Influence of weather, road conditions, and other factors may cause TSR to fail or lead to late alarms.
- Use TSR based on your needs, traffic, and road conditions.

Intelligent Speed Limit Control (ISLC)

- The intelligent speed limit control (ISLC) system integrates ACC and TSR. With the system enabled, if the vehicle travels faster than the detected

speed limit, a confirmation prompt is displayed asking whether to set cruise speed to that limit. After the driver confirms (roll down ② ACC speed control lever), the system will automatically set cruise speed to the limit to prevent speeding.



- This function is accessible at the 20-95 mph (30-150 km/h) range of speed.

How to Use

- To enable or disable ISLC, go to infotainment touchscreen → → ADAS → Driving Assist → TSR → ISLC switch.
- When the TSR system is disabled, the ISLC switch is greyed out and unusable. ISLC is turned off at this time. The ISLC switch will be usable after the TSR system is enabled again.
- ISLC can be activated provided that ACC is activated.

CAUTION

- ISLC integrates ACC and TSR. Therefore, ACC and TSR function precautions must be followed during use (see the previous chapters for details).
- ISLC is a driver assistance system, so the driver must keep control of the vehicle at all times.

CAUTION

- ISLC performance depends on weather conditions, lighting, and traffic sign visibility. The system may fail to or incorrectly identify the sign at night or sunset, in rain, fog, haze, snow or dust, when light is coming from the back of the vehicle, or when there is a sudden change in lighting.

WARNING

- ISLC serves as a driver assistance function only, so the driver must be fully responsible for driving safety.
- Influence of weather, road conditions, and other factors may cause ISLC to fail or lead to late alarms.
- Use ISLC based on your needs, traffic, and road conditions.

High Beam Assist (HMA)

High beam assist (HMA) assesses current driving conditions by using multi-purpose camera sensors and automatically activates or deactivates the high beam accordingly, when vehicle speed exceeds 22 mph (35 km/h).

Status Description

- HMA standby: When the function is enabled but not activated yet, is displayed on the instrument cluster.
- HMA activated: With the function enabled, when the light switch is on "Auto", the light meets conditions, and vehicle speed exceeds 22 mph (35 km/h), is displayed on the instrument cluster.

- HMA failure: HMA has failed, and  is displayed on the instrument cluster.

How to Use

- Enable or disable HMA in **Vehicle Settings**  → **ADAS** → **Driving Assist**.
When the vehicle is started, the system defaults to previous settings.
- With the function enabled, when you set the light switch to the auto lights position, the light meets conditions and vehicle speed exceeds 22 mph (35 km/h), the system automatically switches between low and high beams based on the current driving environment.

Precautions

- The HMA system is an auxiliary light control function. While it is recommended to use the system at high vehicle speeds, the system cannot completely replace the driver's judgement. The driver must observe road regulations and actively switch between high and low beams according to road condition changes at all times.
- When the vehicle is in a high dynamic state, for example when the ABS or ESC is activated, beam switching is suppressed.
- HMA system exits when you turn fog lights or turn signals on, set wipers to fast mode, are backing up, or set the light switch to a position other than auto lights, or when the environment has too much lighting.
- Even when HMA is working, the driver must respond to possible situations where the HMA is triggered in error or fails to work due to unavoidable environmental factors and conditions. Typical situations are:

- The driver's stick operation to switch to the high beam is prioritised.
- The weather, such as fog, rain or snow, is extremely terrible for driving.
- There are traffic participants with poor lighting (such as pedestrians and bicycles), railways or waterways nearby, or wild animals on the roads.
- There are highly reflective objects around (e.g., traffic signs on motorways, water reflection on the road surface, etc.).
- The front windscreen is dirty, covered in mist, or blocked by stickers or decorations.
- In case there is a collision or the sensor has been reassembled, it is recommended to go to a BYD authorised dealer or service provider for sensor calibration so as to avoid affecting system performance.

WARNING

- HMA serves as a driver assistance function only, so the driver must be fully responsible for driving safety.
- Influence of weather, road conditions, and other factors may cause HMA to fail.
- Use HMA based on your needs, traffic, and road conditions.

Lane Departure Assist (LDA)

Lane Departure Warning (LDW)



The lane departure warning (LDW) system detects the lane lines ahead through a multi-purpose camera. When the vehicle speed is 38-93 mph (60-150 km/h) and

the driver unintentionally drifts out of the lane, the LDW system warns the driver by steering wheel vibration, audible alarm, and an instrument cluster prompt.



Lane Departure Prevention (LDP)*

- The lane departure prevention (LDP) system identifies lane lines ahead through a multi-purpose camera. If the driver unknowingly departs from the lane at a vehicle speed between 38-93 mph (60-150 km/h) such that the vehicle is about to roll over lane lines, the system, when activated, slightly turns the steering wheel by providing reverse torque through the electronic power steering (EPS) system to prevent lane departure.
- If LDP system is activated for over five seconds, it gives visual and audible alarms at the fifth second and continues until this activation ends in the form of audible and visual alarm. If the system is activated twice or more within a continued 180-second cycle, the system alarms. For the third intervention (and any further ones), alarms are extended by at least 12 seconds.

How to Use

- Enable or disable this function in infotainment touchscreen →  → ADAS → Driving Assist → Lane Support System (LSS).
- There are three LDW modes: audible alarm only, steering wheel vibration only, and audible alarm + steering wheel vibration.
- When LDW or LDP is enabled,  is displayed on the instrument cluster.
- When activated, LDW gives alarms (in the form of audible alarm, visual alarm, and steering wheel vibration). On the instrument cluster, virtual lane

lines on the side where the vehicle rolls over lane lines turn red.

- When activated, LDP gives alarms (in the form of audible and visual alarms). On the instrument cluster,  flashes twice, virtual lane lines on the side where the vehicle rolls over lane lines turn green.
- In the event of malfunction,  is displayed.

System Limitations

In a complex road traffic environment, the LDA system may detect the lane line incorrectly or fail to detect the lane line. In the following cases, the system may not work or its performance may be significantly degraded:

- Poor visibility on snowy, rainy, or foggy days.
- Dirty or fogged front windscreen, or blocked multi-purpose camera.
- Glaring from direct sunlight, reflection, or oncoming vehicles.
- Sudden changes in light, such as when the vehicle is entering or exiting a tunnel.
- Lane lines obscured by tree's shadows on roads in direct sunlight of sunny days.
- Unidentifiable road boundary with grass, soil or kerb.

Precautions

- LDW will be suppressed if a turn signal is used and the vehicle changes lane as indicated by the turn signal.
- LDW may be suppressed if the vehicle travels over lane lines or if lane lines are unclear, too thin, worn, blurred, or covered by dirt/snow.

- LDW may be suppressed if the lane is too wide or too narrow, if the number of lanes increases or decreases, if lane markings change suddenly on ramps or exits, or in situations of complex line arrangements.
- LDW may be suppressed on slopes or winding roads when the vehicle travels too close to the vehicle ahead or when the vehicle ahead obscures lane lines.
- LDW may be suppressed when the vehicle jolts, accelerates or decelerates too quickly, or takes a sharp turn.
- The system operation may be affected if the windscreen within the visual field of the multi-purpose camera is cracked, if the front windscreen glass is dyed or coated in a manner that is not compliant with standards, if any reflective object is placed on the dashboard, or if any other object interferes with camera sight.
- For safety reasons, do not test LDW function on your own. The function will be interrupted if the multi-purpose camera is blocked by any object or exposed to strong lights. The function recovers once conditions return to normal. If it does not, it is recommended to contact a BYD authorised dealer or service provider.
- Disabling the LDW is recommended under any of the following circumstances:
 - Driving in a sporty style.
 - Severe weather conditions.
 - On uneven roads.
- Situations where lane lines may not be identified include, but are not limited to:
 - Unclear lane lines.
 - Incomplete lane lines.

- Situations that may cause recognition difficulty or late function activation of the multi-purpose camera include, but are not limited to:
 - The multi-purpose camera comes off, is loosely installed, or is blocked.
 - The vehicle is running under extreme weather, such as rain, snow, or smog.
 - The multi-purpose camera is partially or completely blocked.







WARNING

- LDA serves as a driver assistance function only, so the driver must be fully responsible for driving safety.
- Influence of weather, road conditions, and other factors may cause LDA to fail.
- Use LDA based on your needs, traffic, and road conditions.

Emergency Lane Keeping Assist (ELKA)

The emergency lane keeping assist (ELKA) system identifies lane lines ahead through a multi-purpose camera and identifies vehicles approaching from behind on the adjacent lanes through rear corner mmWave radars. It comes to work within the 32-93 mph (50 km/h-150 km/h) vehicle speed range when the vehicle drifts out of solid lane lines, is about to cross a road edge, or has a risk of colliding with oncoming vehicles or vehicles that are passing it on adjacent lines. The system activates EPS system to provide reverse torque, keeping the vehicle in the current lane.

How to Use

- To enable or disable ELKA, go to infotainment touchscreen →  and tap ADAS → Driving Assist → Emergency Lane Keeping Assist.
- When ELKA is activated,  flashes on the instrument cluster.
- In the event of ELKA malfunction,  is displayed on the instrument cluster.
- If you disable ELKA manually by pressing buttons,  is displayed.

System Limitations

- The ELKA system may detect incorrect or no lane lines in complex traffic. The following situations may lead to failure or performance degradation of the system:
 - Poor visibility on snowy, rainy, or foggy days.
 - Dirty or fogged windscreen, or blocked multi-purpose camera.
 - Glaring from direct sunlight, reflection, or oncoming vehicles.
 - Sudden changes in light, such as when the vehicle is entering or exiting a tunnel.
 - Lane lines obscured by tree's shadows on roads in direct sunlight in sunny days.
 - Unidentifiable road boundary with grass, soil or kerb.

Precautions

- Situations where lane lines may not be identified include, but are not limited to:
 - Pedestrians, animals, and specialty or specially-shaped vehicles.
 - Unclear or incomplete lane lines.

- Situations that may result in detection failure of the multi-purpose camera or late alarms include, but are not limited to:
 - The multi-purpose camera comes off, is loosely installed, or is blocked.
 - The vehicle is running under extreme weather, such as rain, snow, or smog.
 - The multi-purpose camera is partially or completely blocked.
- Situations that may result in detection failure of mmWave radars or late alarms include, but are not limited to:
 - MmWave radar(s) come off, are loosely installed, or are blocked.
 - The vehicle is running under extreme weather, such as rain, snow, or smog.
 - The vehicle encounters certain metal guardrails or similar road conditions.

WARNING

- ELKA serves as a driver assistance function only, so the driver is fully responsible for driving safety.
- Influence of weather, road conditions, and other factors may cause ELKA to fail.
- Use ELKA based on your needs, traffic, and road conditions.

Blind Spot Detection System (BSA)

- The blind spot assist (BSA) system includes Blind Spot Detection(BSD), Rear Cross Traffic Alert(RCTA), Rear Cross Traffic Braking(RCTB), Rear Collision Warning(RCW), and Door Open Warning(DOW). It detects the environment behind the vehicle through corner mmWave radars on

both sides of the rear bumper so as to remind the driver of safe driving.

Blind spot detection (BSD)

At vehicle speeds between 10-93 mph (15-150 km/h), if a rear corner mmWave radar detects a vehicle in blind spots on an adjacent lane or a vehicle approaching quickly on the adjacent lane, the indicator on the corresponding side mirror lights up. If the turn signal for the same side is turned on at this moment, the alarm indicator on the side mirror flashes to alert the driver of a risky lane change.

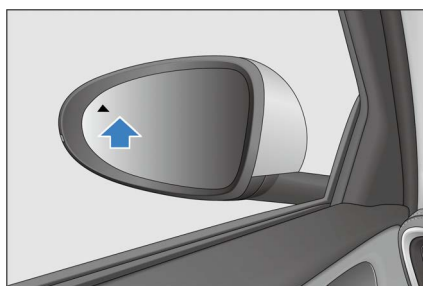

Rear cross traffic alert (RCTA)

When the vehicle is reversing at a speed no more than 9 mph (15 km/h), the RCTA system detects targets travelling in the side and rear blind spots through rear corner mmWave radars. If the system determines that a target approaching from behind the side of the vehicle poses a risk of collision, the side mirror warning indicators flash and an audible alarm is given to alert the driver, reducing the possibility of collision.

Rear cross traffic braking (RCTB)

When the vehicle is reversing at a speed no more than 5 mph (9 km/h), the RCTB system detects targets travelling in the side and rear blind spots through rear corner mmWave radars. If the system determines that a target approaching from behind the side of the vehicle poses

a risk of collision, it performs emergency braking automatically.

Rear collisions warning (RCW)

At vehicle speeds between 4 mph (5 km/h) and 90 mph (146 km/h), if the rear corner mmWave radar detects a risk of collision with a vehicle approaching quickly from behind on the current lane, the hazard warning light turns on to warn the driver in that vehicle against a possible collision.

Door open warning (DOW)



DOW is realised with rear corner mmWave radars installed on both sides of the rear bumper. When the vehicle is stationary with doors unlocked, the system keeps indicators on side mirrors solid on to warn the driver if moving objects, such as bicycles or automobiles, approach from behind on an adjacent lane. If the driver attempts to open the door at this time, indicators on side mirrors begin to flash and a chime sounds.

Cruise button operation

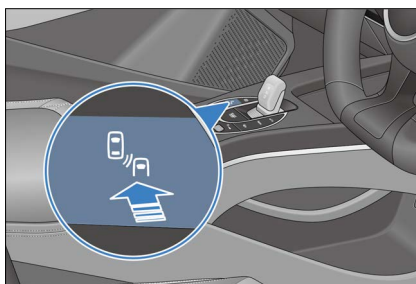
- To enable or disable BSD, RCTA, RCTB, RCW and DOW, go to infotainment touchscreen →  → **ADAS** → **Active Safety** → **Blind Spot Assist**. When the vehicle is started, the system defaults to previous settings.



- When the blind spot assist system is disabled, no relevant indicators are displayed on the instrument cluster.

- When the blind spot assist system is on standby, if vehicle conditions, such as speed or gear status, do not meet the requirements of any function,  is displayed on the instrument cluster and blind spot assist will not be activated.
- If the blind spot assist system malfunctions,  is displayed on the instrument cluster.
- When the blind spot assist system is active,  is displayed, meaning that the function has been activated and can trigger alarms at any time.

Precautions

- While the BSD system provides assistance in monitoring blind spots of rearview mirrors, it cannot replace the driver's observation and judgement. The driver must keep control of the vehicle at all times and drive properly and is fully responsible for the vehicle.
- The BSD system may be unable to provide adequate warning on target vehicles approaching from behind at a high speed.
- The driver must ensure the normal operation of the BSD system, keeping its rear corner mmWave radars in good condition. For example, dirt, snow, or other obstructions need to be cleared right away.
- The BSD system gives a warning if unrelated targets at the rear side or in the rear (such as work zone barriers, large roadside billboards, reflectors in tunnels, or other objects with a large radar cross section) are mistakenly selected as target vehicles.
- Detection may be affected or delayed in some environments. If the radar cross section of the target vehicle is too small (a bicycle, electric moped or pedestrian, for example), the system may fail to identify targets, leading to false alarms. In addition, detection may also be affected or delayed by noise or electromagnetic interference.

RCTB activation scenario:

- A pedestrian is crossing behind the vehicle when it is reversing at a low speed.

System Limitations

- The activation of the RCTB system depends on various factors such as the environment, the state of the vehicle and the target. There is no guarantee that the emergency braking can always be activated in every scenario.
- Under some circumstances, it is difficult for the system to assist the driver, and detection may be affected or delayed. Possible circumstances include, but are not limited to:
 - The vehicle coming from behind changes the lane suddenly.
 - Vehicles coming from behind are detected too late at sharp turns, slopes, or other settings.
 - The target vehicle is obscured.
 - Vehicle coming from behind at a relative speed above 49 mph (80 km/h).
 - The vehicle is on a curve which is too sharp, or is entering or exiting a curve.
 - The vehicle is running under severe weather, such as rain or snow.
 - Rear corner mmWave radar(s) come off, are loosely installed, or are blocked.
 - The vehicle encounters certain metal guardrails or similar road conditions.

- Targets that may not be responded include, but are not limited to: Pedestrians and animals.
- The environment contains electromagnetic interference or other influences.
- Vibration or collision influence on sensor calibration of BSD's rear corner mmWave radars can degrade system performance. If this is detected, contact a BYD authorised dealer or service provider.

! WARNING

- Blind spot assist serves as a driver assistance function only, so the driver must be fully responsible for driving safety.
- Influence of weather, road conditions, and other factors may cause blind spot assist to fail.
- Use blind spot assist based on your needs, traffic, and road conditions.

Head-up Display (HUD)*

Head-up Display (HUD): The head-up display (HUD) function projects important information, including vehicle speed, navigation, speed limit, ACC, lane departure, and BSD into the driver's field of view on the front windscreen. It improves driving safety by preventing the driver from frequently changing the focus of their eyes.

How to Use

- To enable or disable HUD, go to infotainment touchscreen →  → **Vehicle Settings**.
- By factory default, HUD is on and the image is displayed. When it is disabled, no HUD image is displayed. The system

defaults to the previous settings when the vehicle restarts.

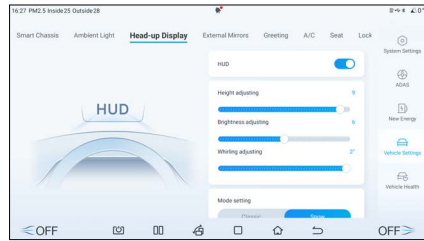



- Height adjusting: adjust the height of HUD virtual image in between -10 and 10. A total of 21 values are available, and the default value is 0.
- Brightness adjusting: adjust the brightness of HUD virtual image in between 1 and 11. A total of 11 values are available, and the default value is 6.
- Whirling adjusting: adjust the angle of HUD virtual image. A total of 11 values are available, and the default value is 0°.
- Mode setting: Used to select "Classic" (default setting) or "Snow" mode according to the environment of the vehicle.
- Settings optional for display: Safe driving assistance can be selected and is enabled by default.

! CAUTION

- Do not put articles on the head-up display.
- Wipe the dust on the dust-proof board with soft cotton cloth or paper towel.
- No water or other liquid is allowed to flow into the opening of the head-up display.

Tyre Pressure Monitoring

Direct Tyre Pressure Monitoring System*

- The direct tyre pressure monitoring system is an auxiliary system that monitors tyre pressure in real time to improve vehicle safety and comfort and reduce tyre wear and energy consumption due to insufficient tyre pressure.
- You can access the instrument cluster menu by pressing the  button on the steering wheel, navigate to the driving information bar by pressing the  and  buttons, and then select the tyre pressure display page using the roller on the button.

Tyre pressure system alarm

- When the pressure of any tyre is lower than 80% of the standard tyre pressure and the system is running, the tyre pressure fault warning light lights up and the tyre pressure value turns yellow. In that case, it is recommended to check for slow air leakage and inflate the tyre to the correct pressure value.
- When the temperature of any tyre is above 185 °F (85°C) for 3 consecutive minutes, the tyre pressure system will give a high temperature alarm, and the temperature value of the corresponding tyre will turn yellow. You are then recommended to stop the vehicle and wait for the tyre temperature to decrease before further driving.
- When one or more tyres leak air quickly and the system is running, the tyre pressure fault warning light flashes constantly and the tyre pressure value turns red. In that case, promptly stop the vehicle and replace

tyres or contact a BYD authorised dealer or service provider.

- When the system is running, if a fault occurs, the tyre pressure fault warning light is solid on after flashing, and the message "No Signal" or "Please check TPMS" is displayed on the instrument cluster. In that case, check the tyre pressure monitoring module, and check for any surrounding electromagnetic source nearby. If the alarm persists for a long time, please contact a BYD authorised dealer or service provider.



CAUTION

- The running time of the tyre pressure monitoring module is related to the daily travel distance and other factors.
- The tyre pressure monitoring module regularly transmits tyre pressure and other information to the display. Therefore, if the tyre pressure drops suddenly or there is a flat tyre, the monitoring module will not transmit data to the display until the next monitoring. In this case, the vehicle may be out of control. If there is a flat tyre and monitoring fails to inform, or if you feel that there is some tyre problems, stop driving immediately instead of waiting for the display to signal an alarm.
- If the tyre pressure monitoring module is installed incorrectly, it will affect the air tightness of the tyre. It is recommended that the installation and replacement of the pressure monitoring module be carried out by professional technicians of a BYD authorised dealer or service provider in

CAUTION

accordance with the requirements of the installation manual.

- Since tyre pressure varies with regional temperatures, inflate or deflate the tyres according to the values displayed on the instrument cluster and the standard tyre pressure values.
- If the vehicle is equipped with non-BYD approved electrical accessories, the tyre pressure monitoring system may be disturbed, do not misunderstand the disturbance as a tyre pressure system failure.
- The tyre pressure system needs to be matched again after replacement of wheel rims or spare tyres* or tyre rotations. Please go to a BYD authorised dealer or service provider to re-match the tyre pressure.

WARNING

- The system does not stop vehicle travelling in the event of abnormal tyre pressure. Therefore, each time before driving, start the vehicle statically to check whether the tyre pressure meets the requirements specified by the manufacturer. If not, do not drive, otherwise vehicle damage or personal injury can occur.
- If pressure is found to be abnormal while driving, check the tyre pressure immediately. If the low pressure warning light comes on, avoid sharp turns or emergency braking, and reduce vehicle speed, pull it over to the kerb and stop as soon as possible. Driving with low tyre

WARNING

pressure can cause permanent damage to tyres and increase the likelihood of tyre scrapping. Serious tyre damage can lead to traffic accidents, resulting in serious injuries or deaths.

Acoustic Vehicle Alerting System (AVAS)

The acoustic vehicle alerting system (AVAS) refers to the alert to pedestrians near the vehicle when it is travelling at low speed in EV mode.

- When the vehicle runs at a low speed, it will make proper alerting sound to alarm the pedestrians.

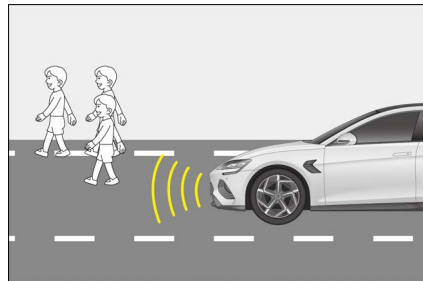

- When driving forward:
 - The alert volume increases with vehicle speed in the range of 0-12 mph (0-20 km/h).
 - The alert volume decreases with vehicle speed in the range of 12-18 mph (20-30 km/h).
 - The alert stops automatically when vehicle velocity is over 18 mph (30 km/h).
- The vehicle makes a continuous and balanced prompt sound when moving in reverse.

How to Use

To turn on or off AVAS, slide down the top status bar on the infotainment touchscreen to display the shortcut page. AVAS has two sound sources: standard and brand. To choose a sound source, go to infotainment touchscreen →  → **Vehicle Settings** → **Notification**. After a sound source is chosen, tap Play to get the corresponding engine sound source.

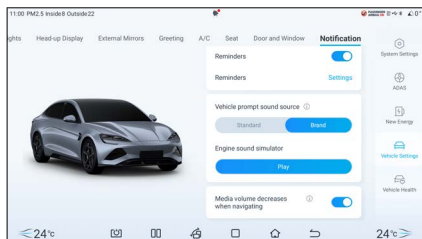

WARNING

- The AVAS pause switch can only be used if there are no other road users within a short distance, and no audio prompt is needed considering the surroundings (for example, in a traffic jam or on the motorway). As long as pedestrians may appear around the vehicle, the AVAS needs to be turned on.
- If the vehicle is running at low speed with AVAS turned off, it is unable to alert pedestrians to the vehicle approaching, decreasing vehicle safety.
- If the AVAS prompt sound cannot be heard when driving at a low speed, stop the vehicle in a relatively safe and quiet place, open a window and drive in R gear, then check whether you can hear an audible prompt from the front of the vehicle. If it is confirmed that there is no sound,

WARNING

contact a BYD authorised dealer or service provider to deal with it.

Panoramic View System

With the ignition switched on, tap **Vehicle View** on the infotainment system homepage or press the  button on the steering wheel to access the panoramic view.



- Landscape mode:
 - Tap the front, rear, right, and left areas of the vehicle. A single view of the vehicle's front, rear, right, and left images is displayed in the image section on the left.
 - In the single front and rear views, double-tap the image section to switch to a 180° perspective displayed in full screen.

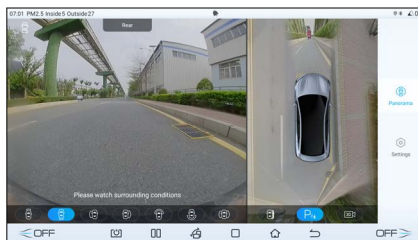

- Tap the radar  in the panoramic view to enable the radar display, and tap it again to disable. When the

radar display is enabled, a warning is displayed as the vehicle is approaching an obstacle.

- Portrait mode:
 - Tap any two of the front, rear, right, and left areas of the vehicle in the lower right section. Views of the two selected areas are displayed in the upper and lower left image sections.
- Tap the vehicle image switching button in the lower right corner to switch between transparent and nontransparent vehicle images.
- After the vehicle starts, the image before last power-off is displayed on the transparent panoramic view screen. Foreign bodies shown may be inconsistent with the actual ones in the underbody and surrounding blind areas. The underbody image update will begin only after the vehicle has started to run and will be complete when the vehicle has been driven beyond its length.

 **WARNING**

- The panoramic view system can provide transparent panoramic view to show the image below the vehicle. This function is only for assisting in observation of area below the vehicle during parking/driving. Investigation of foreign objects below the vehicle and dangerous situations should be carried out in any other manner to ensure the safety of personnel and the vehicle.
- When the vehicle runs at a low speed, the transparent panoramic view function is affected by speed fluctuation or multiple stops, so there will be misalignment between the images below the

 **WARNING**

vehicle and that outside the vehicle.

- The panoramic view system is only to be used for parking/driving assistance. It is not safe to rely solely on this system to park or drive the vehicle, because there are some blind spots in front of and behind the vehicle. The surroundings of the car should be observed in other ways during the parking/driving process, so as to avoid accidents.
- This system uses wide-angle fisheye cameras, so the object on the display screen may appear somewhat deformed in comparison with the actual object.
- When the side mirrors are not extended in place, do not use the panoramic view system; and when the panoramic view system is used for parking/driving, ensure that all the car doors are closed.
- The distance to an object displayed on the panoramic view screen may be different from the distance perceived subjectively, especially when the object is closer to the vehicle. Assess the distance in various ways.
- Cameras are installed above the front grille, side mirrors, and the rear license plate. Make sure the cameras are unobstructed.
- To prevent affecting the performance of cameras, avoid directly washing these cameras when washing the vehicle body with high-pressure water. Wipe any water or dust off the camera in time.

! WARNING

- Protect the cameras from any impact to prevent damage or malfunction.
- After the vehicle is powered on, if you press the panoramic view start button or shift into reverse while the infotainment system is not fully activated, the output on the panoramic view screen will be delayed or the screen will flash. This is a normal part of the camera power-on process.

Parking Assist System

- During vehicle parking, the parking assist system detects obstacles by sensors, and prompts the driver with the proximity of obstacles by an image on the infotainment touchscreen and a speaker alarm.
- The parking assist system helps with reversing. Pay attention to the environment behind and around the vehicle when reversing.
- When you reverse the vehicle, a reversing image will be displayed on the system screen automatically.
- After reversing ends, the interface will be restored.

! REMINDER

- The safety lines for reversing are only for distance reference in no-load condition of the vehicle.
- For your driving safety, when the reversing image is displayed, all buttons will be disabled except some volume and calls-related buttons.

! WARNING

- The parking assist system ceases to operate when the vehicle is moving forward at over 6 mph (10 km/h).
- Do not place any articles within the sensors' working range.
- Do not wash the positions of sensors with water or steam when washing the vehicle, otherwise it would cause a sensor failure.

Parking Radar Switch

- To enable or disable the parking radar system, go to infotainment touchscreen →  → **ADAS** → **Parking Assist**.
- When the ignition is on and EPB is released, the parking assist system is enabled automatically.

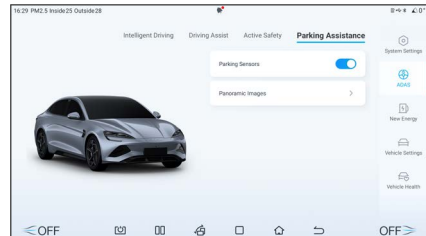

- When enabled, the system raises an alarm if obstacles are found surrounding the vehicle; when disabled, it does not.

Sensor Type

- When the sensor detects an obstacle, an image is displayed on the infotainment touchscreen* according to the location of the obstacle and its distance from the vehicle.
- When the driver conducts parallel parking or reverse parking, the

sensor measures the distance between the vehicle and the obstacle and communicates this information through the infotainment touchscreen and the speaker. Be aware of the surroundings when using this system.

- ① Front right corner sensor
- ② Front left corner sensor
- ③ Rear right corner sensor
- ④ Rear left and right middle sensors
- ⑤ Rear left corner sensor

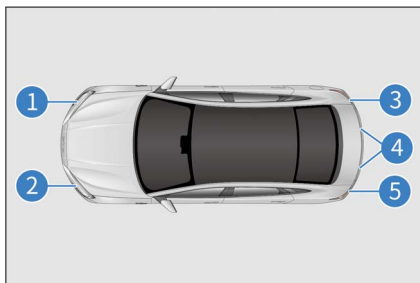



Distance Display Alarm

When the sensor detects an obstacle, the location of the obstacle and its approximate distance from the vehicle is displayed on the infotainment touchscreen, and the speaker beeps.

Working example of centre sensors

Approximate Distance	Touchscreen Display Example	Alarm Sound
About 28~47 in (700~1,200 mm)		Slow
About 12~28 in (300~700 mm)		Fast
About 0~12 in (0~300 mm)		Continuous

Working example of corner sensors

Approximate Distance	Touchscreen Display Example	Alarm Sound
About 12~24 in (300~600 mm)		Fast
About 0~12 in (0~300 mm)		Continuous

Working Sensors and Detection Range

- All sensors are activated upon reversing.
- The illustration shows the sensors' detection range. Sensors have a range limitation, so drivers must check the surroundings before slowly reversing the vehicle.

- ① About 47 in (1200 mm)
- ② About 24 in (600 mm)

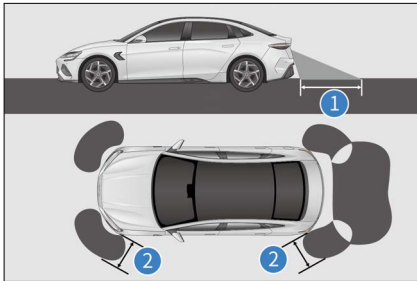

! REMINDER

- The parking assist system is only for assistance, and is not a substitute for personal judgment. Be sure to operate the vehicle based on your observations.
- Sensors will not work properly if accessories or other objects are placed within their detection range.

! REMINDER

- In some cases, the system cannot operate properly and will fail to detect certain objects as the vehicle approaches them. Therefore, be sure to observe the vehicle's surroundings at all times. Do not rely solely upon the system.
- Failure of the reversing radar system  is indicated by a message on the instrument cluster and a beep, contact a BYD authorised dealer or service provider for inspection as soon as possible in the event of the error message.

Sensor detection information

- Certain vehicle conditions and surroundings may affect the sensors' ability to accurately detect obstacles. Detection accuracy may be affected if:
 - There is dirt, water or fog on the sensor.
 - There is snow or frost on the sensor.
 - The sensor is masked in any way.
 - The vehicle leans significantly to one side or is overloaded.
 - The vehicle is moving on particularly bumpy roads, slopes, gravel or grass.

- The sensor has been repainted.
- The vicinity is noisy due to honking of vehicles, motorcycle engines, air brakes of large vehicles, or other noises that produce ultrasonic waves.
- There's another vehicle with parking assist system nearby.
- The vehicle is fitted with a tow eye.
- The bumper or the sensor was hit hard.
- The vehicle is approaching a high or zigzag kerb.
- The vehicle is driving in the sun or in the cold.
- The vehicle is fitted with non-original, lower suspension.
- Except as described above, sensors may not be able to correctly determine the actual distance due to the shape of the object.
- The shape and material of obstacles may prevent sensors from detecting them, especially the following:
 - Electric wires, fences, and ropes.
 - Cotton, snow, and other materials that absorb radio waves.
 - Any object with sharp edges and corners.
 - Low obstacles.
 - High obstacles facing outwards towards the vehicle.
 - Any object under the bumper.
 - Any object close to the vehicle.
 - Persons near the vehicle (depending on the weaing).
- If an image is displayed on the infotainment touchscreen or there is a beep, it may be that the sensor detects

an obstacle or is interfered. If the issue persists, go to a BYD authorised dealer or service provider for inspection.



CAUTION

- To prevent sensor malfunction, do not rinse or apply steam to the sensor area.

Driving Safety Systems

For better driving safety, the following driving safety systems works automatically based on driving conditions. However, these systems only provide assistance, and excessive reliance on them is not recommended.

Intelligent Power Braking System

The intelligent power braking system is an advanced decoupled electro-hydraulic braking system, incorporating vacuum booster, electronic vacuum pump, and ABS/ESC functionality. The system assists the vehicle braking according to the driver's demands. It offers advanced control functions such as anti-lock braking system (ABS), electronic brake force distribution (EBD), Traction Control System(TCS), Vehicle Dynamics Control(VDC), comfort parking (CST), Hill Descent Control(HHC), Hydraulic Brake Assist(HBA) and controlled deceleration parking brake (CDP) to improve vehicle stability and comfort, and the recovery efficiency of brake energy.

Vehicle dynamic control (VDC)

When the vehicle turns suddenly while running, the VDC system determines the driver's intention based on such information as steering wheel's angle and vehicle speed, and continuously compares with the actual condition. If the vehicle swerves from the normal lane, the VDC corrects the situation by

engaging brakes to the corresponding wheels to help the driver control skidding and maintain directional stability.

Traction control system (TCS)

TCS prevents the drive wheels from skidding during acceleration by reducing the motor power, and, when necessary, applies braking forces to prevent drive wheels from spinning. It makes it easy for the vehicle to start, accelerate, and climb under adverse driving conditions.

WARNING

- TCS may not work effectively in the following situations:
 - When driving on slippery roads, even if TCS is working properly, it may not be able to control the direction and meet power requirements.
 - Do not drive in conditions where the vehicle may lose its stability and power.

Hill hold control (HHC)

After the brake pedal is released, HHC maintains brake pressure for one second to prevent backward sliding.

Hydraulic brake assist (HBA)

When you press the brake pedal quickly, HBA detects that the vehicle is in emergency condition. It quickly increases the brake pressure to the maximum so that ABS can intervene more quickly and shorten the braking distance effectively.



Controller deceleration parking (CDP)* for parking brake

When you hold the "P" button, the CDP function starts working so that the vehicle brakes at a constant deceleration (0.4 g if Parking is engaged but the brake pedal is not pressed, and 0.8 g if Parking is engaged and the brake pedal is pressed)

until the vehicle stops. The function stops working when the "P" button is released.

ESC operation instructions

Intelligent power braking system has the following new functions compared with the original ESC system:

- Brake assist mode
 - It is used to adjust the brake pedal feel. The relation curve between the brake pedal depth and the vehicle deceleration varies across different modes for you to choose a preferred pedal feel.
 - You can select Comfort or Sport in infotainment touchscreen →  → **Vehicle Settings** → **Smart Chassis** → **Brake assist mode**.
- Comfort parking (CST)
 - Comfort parking function: When the vehicle decelerates to stop in a non-emergency situation, the intelligent power braking system reduces the stop-instant suspension pitch and impact by controlling the brake pressure of the four brakes, providing a smooth stop feeling for the driver.
 - Go to infotainment touchscreen →  → **Vehicle Settings** → **Smart Chassis** to enable or disable comfort parking.
 - After the function is triggered, the braking distance may increase by 2-5 cm. Increase the distance from the vehicle or obstacle ahead accordingly before stopping your vehicle.
- Brake disc wiping
 - Brake disc wiping function: When the wiper switch is on or the rain sensor detects rain, the intelligent brake control system applies a small brake pressure to all four brakes so that pads come into contact with discs to remove the water film from the

discs. This shortens brake response time and braking distance.

- As long as the system detects rain or the wiper ON signal, the brake discs are repeatedly wiped at certain intervals to improve safety.
- ESC working
 - If there is a risk of skidding or backsliding when the vehicle starts on a slope, or if either drive wheel is spinning, the ESC indicator flashes to indicate that ESC system is working.
- Disabling ESC
 - If the vehicle gets stuck in snow or mud, ESC may reduce power output from the motor to the wheels. In this case, you may need to turn off the system to get out of the jam.
- Turning off ESC
 - To turn off the ESC system, go to infotainment touchscreen →  → **ADAS** → **Active Safety** → **ESC**. In addition, ESC checks its working status in real time. If ESC OFF switch is pressed while ESC system is working, the system will complete the active intervention control rather than executes the "shutdown" command immediately. ESC is disabled only after the intervention control is complete.
 - Some ESC functions may be re-enabled if you press the ESC OFF switch again or the vehicle speed exceeds the threshold of 49 mph (80 km/h). In order to prevent ESC from being turned off suddenly, ESC can be activated again only when it is not in a vehicle dynamic intervention state.
 - Restarting ESC after the motor is powered off
 - When the ESC system has been turned off, restarting the motor will automatically restart ESC system.

- ESC system start and speed linkage
 - Although already turned off, the ESC system can start on its own if the vehicle becomes extremely unstable as the speed increases and exceeds the threshold of 49 mph (80 km/h).
- When ESC system is activated
 - If the ESC fault indicator  flashes, drive with caution.
- When ESC system is disabled
 - Be careful when ESC is disabled, and drive at speeds suitable for road conditions. The ESC system ensures vehicle stability and its driving force. Never turn it off unless necessary.
- Replacing tyres
 - Make sure all tyres are of the same size, brand, tread pattern, and total load. In addition, be sure to inflate tyres to the recommended pressure.
 - Neither ABS nor ESC will work properly if the vehicle is fitted with different tyres.
 - For details on tyre or wheel replacement, it is recommended to contact a BYD authorised dealer or service provider.
- Tyre and suspension handling
 - The use of any defective tyre or modified suspension affects the driving safety system and may cause the system to fail.

Anti-lock Braking System

- The ABS hydraulic system has two separate circuits, each running diagonally through the vehicle (left front wheel brake connected to the right rear wheel brake). If one circuit fails, two wheels can still be braked.

- ABS helps maintain the steering control by preventing the wheels from locking or skidding when brake is engaged suddenly or on slippery roads.

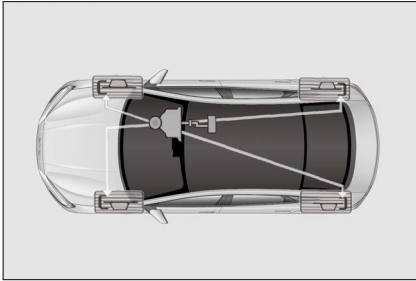

- When the front tyres skid, there is no steering control, which means that the vehicle still moves forward even though the steering wheel is turned. ABS helps prevent locking and maintain steering control since pulsating prompt brake is much faster than human reaction.
- Never pulsate the brake pedal, otherwise ABS may malfunction. While steering away from danger, a firm and steady pressure should always be maintained on the brake pedal for ABS to work.
- When the ABS is working, the brake pedal will vibrate, which may produce noise. This is because the ABS is pulsating the brake quickly, which is normal.

Electronic brake force distribution (EBD)

- The EBD is an auxiliary function of ABS. Before ABS acts, if the skid rate of rear wheel is high, ABS will adjust the brake pressure of rear wheel for a smoother and more ideal brake force distribution.

WARNING

- ABS cannot work effectively under the following conditions:
 - Tyres with inadequate grip are used (for example, excessively worn tyres used on snow-covered roads).
 - The vehicle skids when driving at a high speed on slippery roads.
- ABS is not designed to reduce the braking distance of the vehicle. Always keep a safe distance from the vehicle ahead when:
 - Driving on slippery, muddy, sandy or snowy roads.
 - Driving on roads with multiple potholes or on uneven roads.
 - Bumpy roads.

CAUTION

- If the ABS fault warning light is still on while the braking system warning light is on, immediately park the vehicle in a safe place. It is recommended to contact a BYD authorized dealer or service provider.
- In this case, if brakes are applied, the ABS will not work and the vehicle will become extremely unstable.
- Anti-lock Braking System (ABS) cannot shorten the time and distance needed for braking. This device only helps you control steering when braking. Please always keep a safe distance from other vehicles.
- ABS cannot prevent skidding caused by sudden direction

CAUTION

change, such as trying to make a sharp turn or change lanes suddenly. Always drive carefully at a safe speed, regardless of road and weather conditions.

- ABS does not prevent decrease in stability either. When applying the brake in an emergency, the steering should be moderate. A large or sharp turn during the driving can cause the vehicle to swerve into oncoming traffic or run off the road.
- When driving on wet or soft or uneven roads (e.g., waterlogged concrete roads, waterlogged epoxy painted roads, sandy roads, snowy roads, etc.), vehicles equipped with ABS may require longer braking distances than vehicles without ABS. In such cases, reduce the vehicle speed and keep a greater distance from other vehicles.

Intelligence Torque Adaption Control (iTAC) System*

When the vehicle is running, the intelligence Torque Adaption Control (iTAC) system can determine the driver's driving needs and vehicle state according to the information such as steering wheel angle and motor speed, quickly identify the vehicle state through the unique control architecture and algorithm, and dynamically adjust the driving torque of the front and rear axles, so that the driving state of the vehicle can better meet the driver's needs and the vehicle can still obtain better driving performance under complex road conditions. When the wheels show signs

of slipping, this system can adjust the driving torque of the front and rear axles rapidly to ensure the stability of the vehicle torque and make the vehicle obtain better driving performance under different road surfaces.

- Tap infotainment touchscreen →  → New Energy → iTAC to start.

WARNING

- This function is not designed for unbridled driving. Make sure the braking system work normally in the following situations:
 - Vigorous driving behaviours such as drifting, and driving on continuous bends.
 - Driving on slippery, muddy, sandy or snowy roads.
 - Driving on roads with multiple potholes or on uneven roads.
 - Driving on bumpy roads.

REMINDER

- When there is braking participation or braking action, such as the driver stepping on the brake pedal and ESC triggering, this function will exit the priority guarantee braking.

Driver Attention Warning (DAW)*

Driver attention warning (DAW) system evaluates the driver's degree of fatigue by the vehicle operation status. The driver would be reminded according to the evaluation results to ensure driving safety.

How to Use

With the vehicle powered on, set the warning in → ADAS → Driving Assist → Driver Attention Warning (DAW). For safety considerations, the setting is valid on the current trip only, and will revert to the default mode on the next trip.

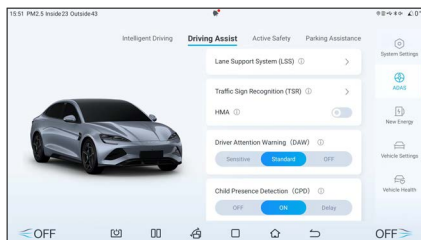

WARNING

- The driver should pull over the vehicle as soon as possible when feeling tired.

CAUTION

- The driver attention warning system is only an auxiliary system and is not capable of effective recognition and alarm-raising in all situations. It cannot completely replace the driver's subjective observation and judgment. The driver must maintain control of the vehicle at all times, complying with all road laws and regulations, and taking full responsibility for the vehicle.

Child Presence Detection (CPD)

After the vehicle is powered off, child presence detection is performed if any door is opened and then all doors are closed or locked. If child presence is detected, an alarm is given in the form

of light flashing and honking. The A/C will be switched on soon after. To cancel the alarm, unlock or open any door.

How to Use

Go to infotainment touchscreen → → ADAS → Driving Assist → Child Presence Detection.

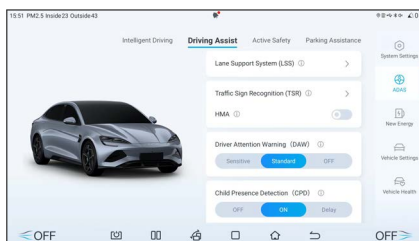

- There are three functions on the setting: **OFF**, **ON**, and **Delay**.
- By default, the system is switched on each time when the vehicle is powered on.
- Tap **OFF** to deactivate the alarm in this trip.
- Tap **Delay** to extend the alarm (for five minutes) in this trip.

System Response

- The system detects life locked in the vehicle, and the first alarm starts in 10s (light flashing & honking) and lasts for six seconds.
- If not cancelled, the alarm (light flashing and honking) escalates within 90 seconds and will last for about 25 minutes.
- The A/C will be switched on three minutes after alarm escalation if it is not cancelled and will keep running for about 30 minutes.

 **WARNING**

- While light flashing, honking, app message prompts, and A/C operation reduces the harm to the children in the vehicle, they cannot completely prevent harms.
- When a reminder is provided, check whether any child has been locked inside the vehicle promptly to avoid further harms.

 **CAUTION**

- Misidentification or false alarm could happen.
- The alarm may be given for adults, children, pets, or other lives detected.
- The alarm cannot be cancelled by unlocking the vehicle from the app.
- The system may not be able to trigger an alarm or switch on the A/C if the SOC is low. Keeping the vehicle at high SOC is recommended.

0-62 mph (0-100 km/h): Full Throttle Experience

Full throttle can be achieved when:

- The high-voltage battery SOC is 95% or above.
- The vehicle is in SPORT mode.
- The acceleration timer page is displayed in the menu.

 **WARNING**

- Please be mindful of all relevant safety measures when experiencing this function.

 **WARNING**

- Before experiencing this function, check if the tyre, brake and other vehicle functions are in optimal conditions.
- Do not use this function when visibility is low (e.g. dust, haze and night).
- Do not use this function on slippery, snowy, muddy, or water-logged roads, nor on grass, sand, etc.
- Do not use this function on roads with complex traffic environments (e.g. at junctions, with pedestrians or other traffic participants).
- Do not use this function before you are fully familiar with the vehicle, so as to avoid accidents caused by incorrect operation.

Other Main Functions

Interior Rearview Mirror

The automatic anti-glare interior rearview mirror is equipped with electronic anti-glare function, which automatically adjusts the lens colour of the mirror according to the surroundings to reduce the interference of rear glare on the driver's field of vision.

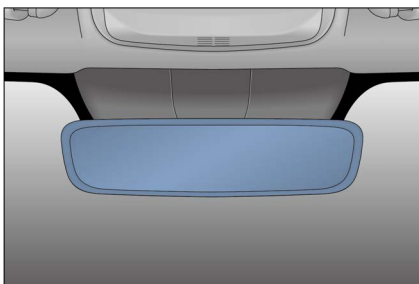



! WARNING

- Do not adjust the interior rearview mirror while driving, as this may obstruct the control of the vehicle, resulting in personal injury or death from accidents.
- Do not hang heavy objects from the interior rearview mirror, or shake or drag it with force.

Power Side Mirrors

Use the associated switches to adjust the side mirrors to see the sides of the vehicle using.

- Selection switches: used to select the side mirror to be adjusted.
 -  : Left side mirror button
 -  : Right side mirror button



- Side mirror adjustment buttons  : used to adjust the side mirror lens.

Press the switch indicating the desired direction.

! REMINDER

- The electric side mirror has the turning function upon reversal. When the vehicle is being reversed, the electric side mirrors automatically turn down*.

Folding Side Mirrors

Folding side mirrors manually

Push the outer edge of a side mirror to rotate it around the folding axis to the locked position.

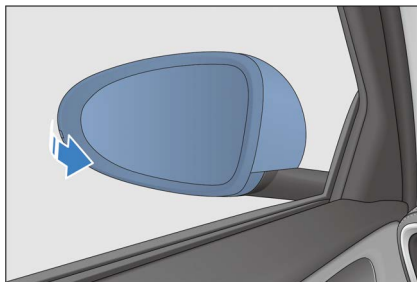

Power side mirror fold switch

Enable or disable the side mirror auto-fold in infotainment touchscreen →  → **External Mirrors.**

- Press the  button to fold the side mirrors with power. Press the button again to unfold the mirrors.
- Both side mirrors fold automatically when the anti-theft alarm system is armed, and extend automatically when the system is disarmed.

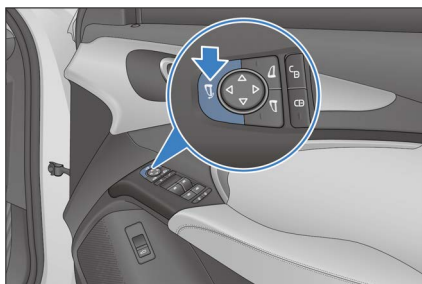

Wipers

Inspect wiper blades for cracks or partial hardening at least every six months. If they are noted, replace wiper blades. Otherwise, the windscreen will streak or will be left unclean after wiping.

CAUTION

- Do not open the bonnet when wiper arms are lifted, otherwise it may damage the bonnet and wiper arms.

Replacing Wiper Blades

With the ignition on, turn on the wiper maintenance function by tapping infotainment touchscreen →  → **Vehicle Health** → **Maintenance Settings**. After this function is turned on, the wiper will run to a high position and then stop to facilitate maintenance and replacement of the wiper. After maintenance, the driver can turn off the function to reset the wiper.

1. Pull up the wiper arm at the driver's side, and then pull up the other at the passenger's side.
2. Press the wiper lock button.

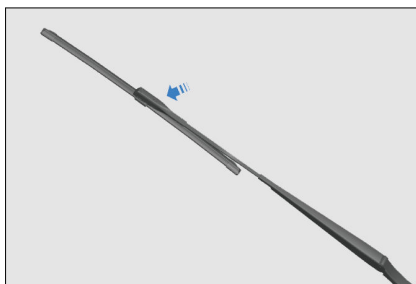

3. Hold the wiper blade and pull it out along the indicated direction.
4. When installing a new wiper blade, follow the reverse procedure.



CAUTION

- Do not open the bonnet when the wiper arms are pulled up, as this may damage the bonnet and wiper arms.
- Handle wiper blades with care. Do not push the wiper arm to let the wiper blade straightly strike onto the windscreen.
- Do not bend the wiper blade, and do not obstruct the wiper blade when the wiper is in operation.

05

IN-VEHICLE DEVICES

Infotainment System.....	148
A/C.....	151
BYD App.....	158
Storage.....	159
In-Vehicle Devices.....	162

Infotainment System

infotainment system starts to work. To better experience infotainment functions, such as intelligent voice control, apps and video call, the system must be used after network connection.

Infotainment Touchscreen

When the ignition is on, the initial screen is displayed for several seconds and the

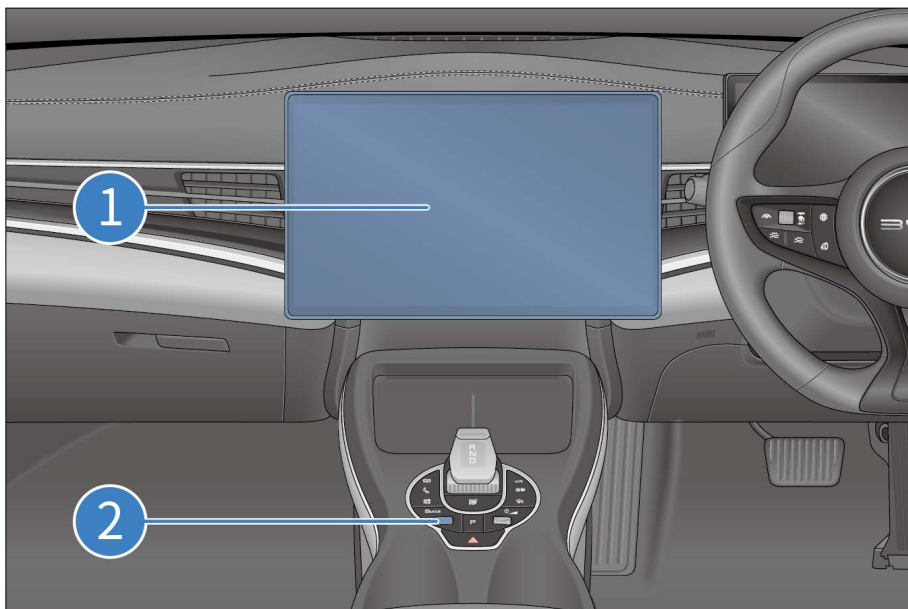

① Infotainment touchscreen (PAD)

② Scroll button

- When the infotainment system is already started, press the button to turn off the infotainment system, press again to turn it on, and press and hold the button for three seconds to restart the infotainment system.
- When the infotainment touchscreen is on, scroll up (forward direction) to turn volume up or down (rear direction) to turn volume down. Volume ranges from 0 to 39. A mute icon is displayed when volume is 0.

Reset to factory settings

- If you are sure to reset to factory settings, infotainment system will be reset to the factory settings.
- During the process, do not touch any button on the infotainment touchscreen or turn off the power supply, or errors may occur.
- The process takes two to five minutes, please wait patiently.

WARNING

- Do not use a high-power inverter in the vehicle, as this may cause infotainment system malfunction.
- Do not format or root the device without authorisation, as this may cause infotainment system or vehicle malfunction.
- In driving, please use the infotainment system in landscape mode wherever possible for your safety.

CAUTION

- To prevent damage to the touchscreen:
 - Touch the screen gently. If there is no response, remove finger from the screen, then touch it again.
 - Clean the screen with a soft damp cloth. Do not use any detergent.
- Using the touchscreen
 - When the screen temperature is low, the image displayed may be darker or the system may work slightly slower than normal.
 - The screen may be dark or difficult to see when you are wearing sunglasses. In that case, change the viewing angle or take off the sunglasses.
 - Touchscreen buttons that are greyed out cannot be operated.
- The touchscreen interface shown here is for reference only.
- It is recommended to contact a BYD authorised dealer or service provider in the event of a failure.

Navigation Bar

Navigation Bar

↶ : returns to the previous page or exits the program.

🏠 : returns to the homepage.

☐ : shows recently opened applications.

📱 : switches between landscape and portrait touchscreen modes.

☐☐ : splits screen if applications support.

🔒 : enables screen saver.

⚙️ : goes to vehicle setting screen.

- The customised map* allows for destination searching, route planning, navigation (online or offline), real-time traffic conditions, voice broadcast, and route recommendation. You can also add home, work and favorite destinations.

- Most interactive controls are on the left side of the map for searching for charging piles, parking lots, and other interested places easily.

Gestures and Responses

Gestures and associated system responses are:



- Tapping: opens applications, selects functions, clicks icons on the touchscreen, or types characters.
- Dragging: touching and dragging an icon, thumbnail, or preview to the target position to change its location.
- Swiping: operational on homepage and app screens.

- Double-tapping: zooms in or out an image.
- Spreading/pinching: zooms in or out an image with two fingers.

BYD Assistant

BYD Assistant

BYD Assistant is an intelligent voice assistant that responds to your voice commands, such as requesting navigation, playing music/radio, making a phone call, and controlling in-vehicle devices.

- Waking up BYD Assistant:
 - On the steering wheel, press the  button.
 - On the infotainment touchscreen, tap .
 - Say the wake-up word: Hi, BYD.
- Your voice commands can be recognised after system wake-up.
- Give any instructions.
 - This may be "Go home" (shortcut locations set), "Play music", "Make a call" (contacts data and Bluetooth connection required), "Set the temperature to 23°C" , or "Turn on the seat ventilation for the driver". BYD Assistant then performs the recognised instruction.

Bluetooth Call

Bluetooth Call



Connection

1. On Bluetooth Call screen, tap **Please connect Bluetooth** to establish connection.

2. Tap **Scan for device** to search for available devices.
3. Pair the available device, and make sure the pairing code displayed on your phone is consistent with the code on the touchscreen.
4. Set Bluetooth when connection is complete.

Bluetooth Call

Go to the dialing screen when Bluetooth is connected.

- Tap **Contacts**, **Call log**, and **Missed calls**, or use dial keypad to make a call.
- Tap  to zoom in or out the dialing screen.
- Tap  to display or hide the dial keypad.
- In panoramic view screen, a small window pops up to inform driver of a call.

File Management

File Management

New folder

- Go to file management screen to create new folders. You can enter the folder name, and tap **OK** or **Cancel** to perform actions.
- Tap the top of the file management screen to change file sources.

Search

- Tap **Search** on the upper left corner and enter file names to search for target files.

Cut / Copy

- Touch and hold any file, select target files and operation (Copy, Move and Delete), and then go to the edit status.

Rename

- Touch and hold any file, select Rename in dialog displayed, rename the selected file, and then tap **OK**.

Delete

- Touch and hold any file, select files, and then tap Delete.

Sort

- Files are sorted by name by default. You can also sort them by size, type, or time.

Attributes

- Touch and hold any file, select a file, and then tap **Details** to check its attributes.

A/C

A/C Panel

- ① AUTO

- ② A/C ON/OFF

- ③ Front windscreen defroster

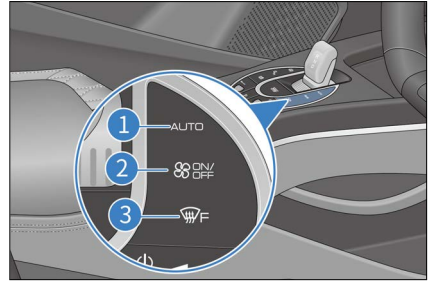

A/C Operation Interface

A/C settings interface



- | | | | |
|---|-------------------------|----|-------------------------------------|
| 1 | A/C setting | 10 | Front windscreen defroster |
| 2 | Air purification system | 11 | Rear defroster |
| 3 | Vent/Heat | 12 | Circulation mode |
| 4 | A/C operation interface | 13 | ION |
| 5 | A/C ON/OFF | 14 | Front passenger temperature control |
| 6 | Auto mode | 15 | Fan speed control |
| 7 | A/C button | 16 | Air distribution |
| 8 | Max cooling | 17 | Driver's temperature control |
| 9 | Ventilator | 18 | DUAL |

! REMINDER

- A/C odor:
 - It is normal that there may be a damp and moldy smell just after the A/C is turned on. During the operation of the automobile A/C, A/C condensation often remain in the evaporator, and the wet evaporator can easily absorb unfiltered body sweat,

! REMINDER

- smokes, etc., inside the vehicle. Condensation not blown dry makes the dark and damp evaporator surface prone to mold, which is very likely to produce unpleasant odors by long-term fermentation.
- How to prevent A/C odors:



REMINDER

- Turn off the A/C and ventilate with natural air before parking to keep the air inside the vehicle relatively dry.
- Inspect, clean, or replace the filter regularly.
- Try to keep the vehicle clean and fresh.
- If the odor persists after odor prevention methods are used, it is recommended to contact a BYD authorised dealer or service provider for repair.

Function Definition

Auto mode

- Tap the auto button on the A/C interface, its indicator lights up and the auto mode is activated.
- If any manual control button is pressed in automatic operation mode, the corresponding status of the button pressed will be set and other statuses will continue to be adjusted automatically.

ON/OFF

- Press this button or tap "ON" on the A/C operating interface to turn off the A/C. The air outlet mode keeps unchanged, while the air input mode turns to recirculation mode. Press this button or tap "ON" again to turn on the A/C.
- With the A/C turned off, press this button or tap "ON" to turn on the A/C in the memorised modes, with the set temperature, fan speed and air outlet mode being those when the A/C was turned off the last time.

Fan speed control

Tap the suitable blower speed level button to set the blower speed at a desired level. A higher blower speed level indicates a higher air volume.

Front windscreen defroster

- Press this button on A/C control panel or tap "Front" on the infotainment touchscreen to distribute air to the front windscreen and side windows. Press this button again or tap "Front" on the infotainment touchscreen; the A/C will return to the status used last time.
- Press this button on A/C control panel or tap "Front" on the infotainment touchscreen to activate the defrosting and demisting function and no matter whether the compressor control button is operated or not, the A/C will also be turned on.

Temperature regulation

- Driver's temperature control
 - Individual mode: Temperature regulation on the driver side.
 - Relative mode: Temperature regulation on the driver and front passenger side.
 - To increase/decrease the temperature, tap the upper/lower arrow on the screen, or touch the temperature display area and then swipe downwards/upwards.
- Front passenger temperature control
 - Individual mode: Temperature regulation on the front passenger side.
 - Relative mode: When the front passenger's temperature control is operated in relative mode, the A/C system will automatically switch to individual mode.
 - To increase/decrease the temperature, tap the upper/lower

arrow on the screen, or touch the temperature display area and then swipe downwards/upwards.

- "Lo"/"Hi" is displayed when the temperature is set to the lowest/highest value.

DUAL

- Tap this button to switch from individual mode to relative mode.
- Individual mode: The temperature of the driver's side and front passenger's side can be set separately. When the individual mode is selected, the button icon lights up.
- Relative mode: Adjust the driver side and front passenger side set temperature at the same time by the driver side temperature control. In the relative mode, the press icon is grey.
- When the front passenger's temperature control is operated in relative mode, the A/C system will automatically switch to individual mode.

Max cooling

Tap this button to switch the A/C to the maximum cooling control mode, then the full cooling mode is activated and the compressor begins to work. The temperature is set to "Lo", the fan speed is set to the maximum, the recirculation mode is activated, and air is directed to face level. Tap this button again to deactivate A/C ventilation control and enter AUTO mode.

A/C button (cooling/heating)

Tap this button to turn on the A/C (cooling/heating), the icon lights up and cooling or heating begins. Tap this button again to turn off the A/C, the icon goes out and the compressor stops working.

Circulation mode

Tap the circulation button. The internal circulation icon is displayed, and the air inlet mode turns to internal circulation. Tap it again to switch to external circulation mode.

Rear defroster

- With the vehicle power in "OK" mode, tap this button to activate the rear windscreen defroster/demister and side mirror defroster/demister*.
- The thin electric heating elements inside the rear windscreen and side mirrors will make the windscreen and mirrors clear. After the windscreen and mirror surfaces are clear, tap this button again to turn off the defroster/demister. After the defroster/demister works for 15min, the system automatically shuts down.



WARNING

- Do not touch the side mirrors when the rear defroster is activated, because their surfaces will be hot.
- When cleaning the inside of the rear windows, take care not to scratch or damage electric heating wires or junctions.
- When the ignition is off, be sure to turn off the defroster switch to prevent the low-voltage battery from discharging.

Ventilator

- Tap this button to activate A/C ventilation control. The outlet air is natural air, and the fan speed is 1 by default without cooling or heating. Tap this button again to exit.

Air distribution

- Air distribution selection

- Tap the corresponding icon on the infotainment touchscreen to select the corresponding blowing mode.
- You can turn on multiple air distribution modes at a time (up to three).
- Adjustments can be made according to the following air supply.

Blowing face ➔ : Air flows to the face level.

Blowing legs ↓ : Air flows to the foot level.

Defrost  : Air flows to the front windscreen and side windows.

Intelligent A/C ON Method

Remote A/C ON with intelligent key

- You can turn on the A/C through the remote control key to gain a comfortable interior environment in advance.

Turning on A/C by voice

- Control the A/C settings by the voice button on the steering wheel or by saying "Hi, BYD".

Turning on A/C by cloud service

- You can turn on the A/C through BYD app interface to gain a comfortable vehicle interior environment in advance.

Usage Precautions

- To quickly cool down the interior after long exposure to sunlight, drive for a few minutes with the windows open to exhaust hot air and speed up A/C cooling.
- Make sure that the air intake grille in front of the windscreen is not blocked (for example, by leaves or snow).

- Avoid blowing cool air onto the windscreen in humid weather. The inner and outer temperature difference can cause glass fogging.
- Keep the space under the front seats clear to improve air circulation.
- In cold weather, run the fan at high speed for one minute to remove snow or moisture from the intake passage and reduce fogging.
- In dusty or windy driving conditions, close all windows. If the dust raised by other vehicles also enters the vehicle even if all windows are closed, it is recommended to set the air intake mode as recirculation mode and set the blower speed at any position other than "0".
- To speed up cooling, adjust the temperature to "Lo" and use the recirculation mode for a few minutes.
- Use recirculation mode for a few minutes for quick heating in cold weather, and switch to fresh air mode to prevent fogging after cabin is heated up.
- In heating mode, press the compressor control button to light up the button (turning on the compressor), which can reduce airflow moisture.
- In the ventilation mode, the system introduces the natural wind from outside, which is suitable for spring and autumn.

Vents

To access the A/C setting page, go to infotainment touchscreen .

The vent area is the adjustment area of A/C vents. Touch the sliding area to adjust the air outlet direction.



- Driver side front blowing button
 - Press this button to distribute air to the driver. The air begins to sweep around the driver's head.
- Driver side surrounding button
 - Driver side vent starts blowing surrounding people to avoid human body.
- Driver side air sweep button
 - Driver side vent starts blowing mode and wind direction begins to sweep horizontally.
- Driver side free wind button
 - The left vent and right vents on the driver seat are adjusted manually, you can adjust the wind direction casually.
- Driver seat side air vent close button
 - The left vent and right vents on the driver seat will close.
- Smart vent button
 - The A/C will automatically switch various air outlet modes such as front blowing, blowing surrounding and air sweeping according to the state.
- Front passenger side front blowing button
 - Press this button to distribute air to the front passenger. The air begins to sweep around the front passenger's head.

- Front passenger side surrounding button
 - Front passenger side vent starts blowing surrounding people to avoid human body.
- Front passenger side air sweep button
 - Press this button to start sweeping air on the front passenger side. The air begins to sweep in the range of left and right vents.
- Front passenger side free wind button
 - The left and right vents on the front passenger seat are adjusted manually. Users can adjust the air direction of these two vents at will.
- Front passenger seat side air vent close button
 - The left and right vents on the front passenger seat will be closed.

Rear vent

- Use the vent stick to adjust the outlet angle.
- Turn the roller to increase/reduce air flow or to open/close the vent.

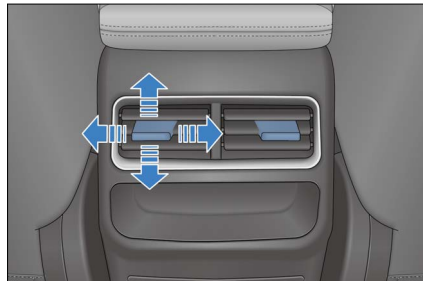

Air Purification System

The air purification system purifies airborne PM2.5 particles. When A/C is turned on, the system thoroughly removes PM2.5 particles from the air blown into the cabin.

Air purification operation interface

Tap "Air purification" on the infotainment page. The PM2.5 operation interface is displayed.

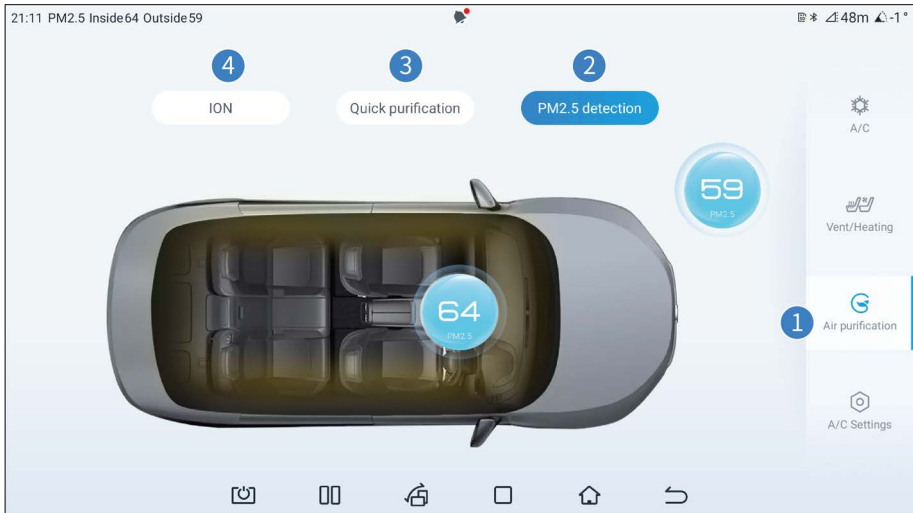

- 1 Air purification
- 2 PM2.5 detection

- 3 Quick purification
- 4 ION

PM2.5 detection

Tap this button to light it up and activate detection of real-time PM2.5 concentration inside/outside, which will be displayed on the infotainment touchscreen. The detection stops when the button turns off.

Quick purification

Tap this button to activate quick purification, and tap it again to deactivate.

ION

- Function: sterilisation, air purification, refreshing.
- Tap the ION button on the A/C or air purification interface to inactivate or activate the ION.

REMINDER

- The PM2.5 value detected by the on-board air purification (PM2.5) detector is the PM2.5 value in the air near the vehicle carrying the device in a short time, which should be different from the daily or real-time PM2.5 value declared by national and relevant government authorities.
- The frequency of PM2.5 detection should be reduced in the following environments:
 - Sandstorms and other such extremely harsh environments.
 - Cold regions (with ambient temperature below -4°F or -20°C).

! REMINDER

- High humidity environments (relative humidity >90%).
- Environments with a change in temperature (prone to condensation), such as driving in from a cold environment to a high-temperature indoor environment or parking lot.
- Running maximum air flow speed in internal circulation mode can quickly reduce the concentration of fine particles in the air inside the vehicle.
- In order to reduce odours from the A/C, if the A/C is already turned on, the A/C blower may keep running for a while after the vehicle is powered off and locked. That is because the condensed water on the surface of the evaporator needs to be dried to prevent mold fermentation. It is normal for the A/C blower to start running automatically when you lock the vehicle. No need to worry about it.

A/C Settings

① A/C settings interface

- Press this button to display A/C Settings screen.
- Press this button again to hide A/C Settings screen.

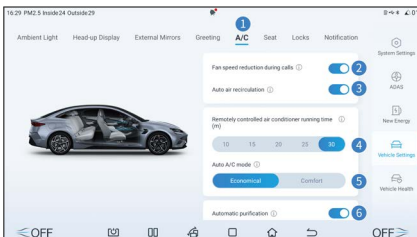

② Fan speed reduction during calls

- Tap this button to enable this setting.

③ Auto air recirculation when parking

- Tap this button to enable this setting.

④ Remote A/C schedule mode

- Tap this button to set the time for remote A/C running.

⑤ Auto A/C Mode

- Two options are available: Economical and Comfort.

⑥ Automatic purification

- Automatic purification on/off setting.

BYD App

About BYD App

BYD App

- BYD app is a mobile application of Internet of Vehicle (IoV) developed by BYD independently. It allows you to control the vehicle remotely and check vehicle conditions, delivering cloud era experience of IoV.
- You can search for "BYD" in application markets such as Google Play and App Store to download and install BYD app.

Account Registration

Account Registration

App guidance and the following steps give instructions on signing up and logging in after BYD app installation.

1. Open the app, then tap **Sign up** to go to the registration screen.

2. Enter email address registered in BYD authorised dealer, tap **Send email** to receive verification code, and then enter the code in app.
3. Set your password in password setting screen to complete the registration, and then the homepage is displayed.

CAUTION

- Provide the email address registered at the BYD authorised dealer, or registration will fail.
- In the app, select a country on upper right corner of the screen. The default setting depends on your phone setting.

Vehicle Condition and Control

Vehicle Condition and Vehicle Control

On the BYD app homepage, you can check vehicle information and corresponding control items.

1. The homepage shows remaining driving range, state of charge, abnormal information, driving condition, charging status, A/C status, door and window states, seat heating and ventilation states, and tyre pressure.
2. Tap lock, unlock, light flashing & honking, or light flashing button to activate the corresponding function.
3. Turn on or off A/C on the app homepage, or tap the A/C card to perform other settings.
4. At the bottom of the homepage, check status of seats, doors, windows and tyres on associated screens by tapping the corresponding icons.

5. If you have more than one vehicle under the same account, tap the vehicle name on the upper left corner to switch vehicles.

CAUTION

- The control function of the app is mainly for remote use. To use this function, ensure your phone and vehicle are connected to the Internet.

Individual Centre and Vehicle Management

Individual Centre and Vehicle Management

Tap the icon on the upper right corner to go to the individual centre.

- **Vehicle management:** changes vehicle name and license plate number.
- **Account and security:** gets back or changes password.
- **Settings:** sets message reception, automatic login, and other items.
- **About:** includes privacy policy and information to contact us and give feedback.

Storage

Glove Box

- Pull the handle to open the glove box.
- Push the lid up to close it.

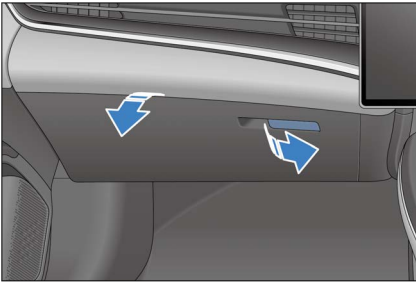

! REMINDER

- To reduce risk of injury in the event of an accident or emergency braking, keep the glove box closed while driving.

Driver's side lifting cup holder*

- Lowering - press the cup or directly press the bottom of the cup holder to lower the cup holder by 1.57 in (40 mm).
- Rising - press ① unlock button to rise the cup holder to the initial position.

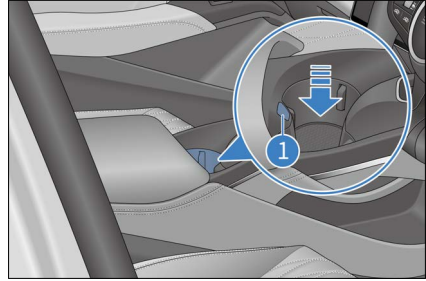

Cubby Box

To use the cubby box, press the switch on the front of cubby box to open it.

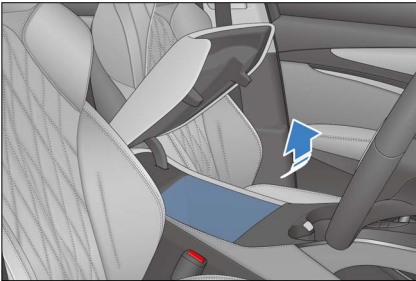

! REMINDER

- Keep the bill box closed while the vehicle is in motion.

! REMINDER

- The cup holder should hold a cup or beverage can securely to avoid any liquid spilling from the cup or can.
- If such sundries as melon-seed shells and fine iron wires are thrown into the sliding groove of the cup holder, the cup holder will be stuck and unable to rise.

Rear Seat Cup Holder

Flip the rear seat armrest to use the cup holder.

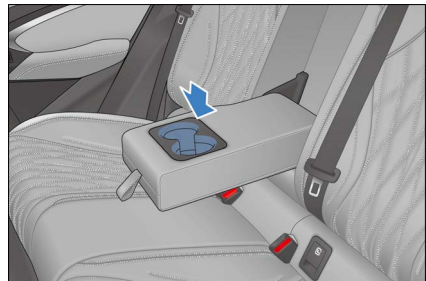

Cup Holder

Front Seat Cup Holder

The cup holder is used to securely hold cups, movable ashtray, beverage can, etc.

CAUTION

- Do not start or brake the vehicle suddenly when the cup holders are being used to prevent spillage or scalding.
- Do not place an open cup or untightened beverage bottle in the cup holder, so as to avoid liquid spillage when you are opening and closing the doors and driving.
- To ensure safe driving, the driver is strictly prohibited from taking the cup out or placing it in the cup holder while driving.

Storage Box on Interior Panel

Storage boxes are available on all doors to hold cups and canned beverages.

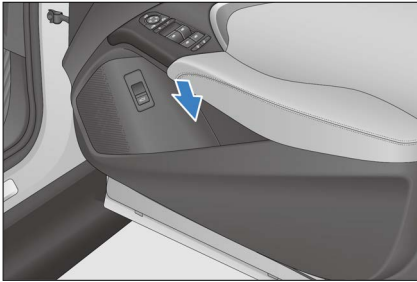

Bill Box

Pull to open the glove box.
Push the lid up to close it.

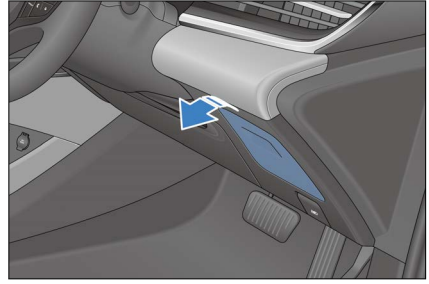

Seatback Pockets

There are seatback pockets at the back of the front seats for magazines and newspapers.

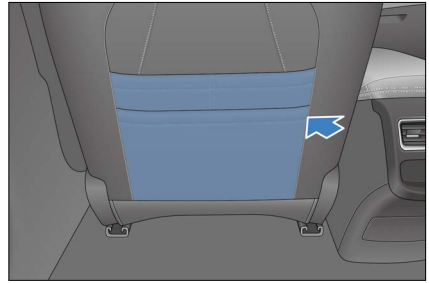

Engine Compartment Storage

Open the bonnet to show the front storage box, which can be used to store articles.



In-Vehicle Devices

Sun Visor

① Sun visor

- To block sunlight from the front, pull the sun visor down.
- To block sunlight from a side, remove the swivel sleeve from the fixed support and turn the visor towards the side window.

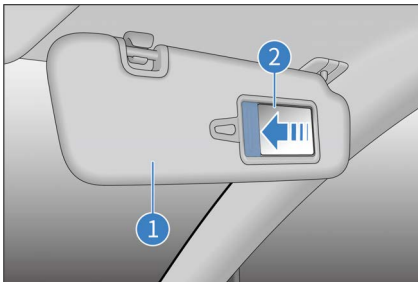

② Vanity mirror

- Flip down the sun visor and slide the mirror cover for use.

! REMINDER

- Correct use of the sun visor improves driving safety and comfort.

Grab Handles

- Pull the grab handle down for use. The handle returns to its original position when released.

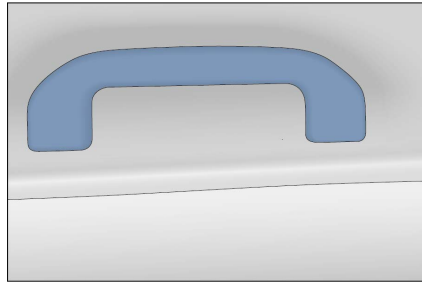

! CAUTION

- Do not hang heavy objects on safety handles to avoid personal injury or damage to the safety handles.

12V Auxiliary Power

- It is used for accessories with 12V DC working voltage and no more than 10A working current.
- The 12V auxiliary power is available only when the ignition has been switched on. Lift the cover to use it.

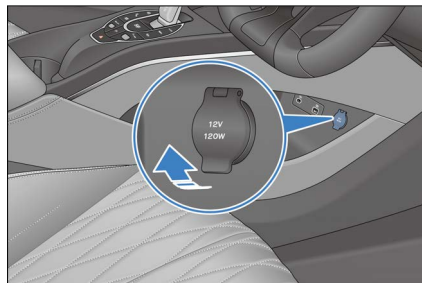

! CAUTION

- To prevent fuses from blowing, the power consumption must not exceed 12V/120W of total vehicle load.
- To prevent draining the low-voltage battery, do not use the



CAUTION

12V auxiliary power supply for a long time when the drive motor is not running.

- When the 12V auxiliary power is not in use, close its cover. Do not insert any object other than a suitable plug into the 12V auxiliary power socket or let any liquid ingress the socket, as it may cause electrical failure.

USB Ports

Front-row USB ports

Front-row USB ports are located at the hollowed-out part below the auxiliary dashboard near the driver's side seat.

- ① Type-C fast-charge port
- ② USB data transmission port

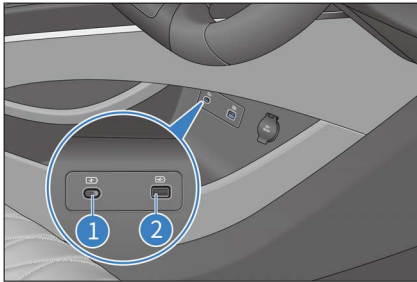

Rear-row USB ports

- Rear-row USB ports are behind the centre console cubby and can be accessed by pressing the cover, and can be opened by pressing the protective cover.
- ① USB charge port
 - ② 60W fast-charge port

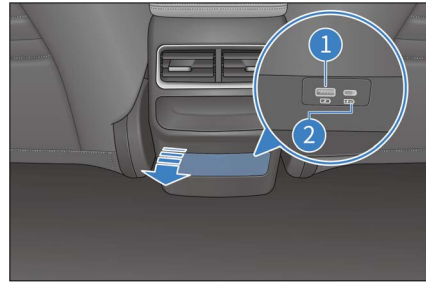

- The power outlet can be used only when the ignition is on.

Wireless Phone Charger

- The wireless phone charging area is located at the front of the centre console. When the ignition switch is on OK, put the phone on the non-slip rubber pad in the wireless charging area with the phone screen facing up. The phone automatically begins wireless charging, and a charging icon is displayed on the infotainment screen.

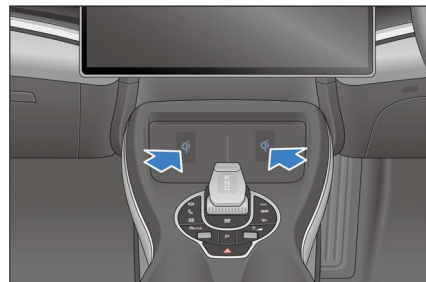

- The wireless charger only works with Qi-certified phones.
- Wireless phone charging uses a coil to transmit electrical energy to a phone battery through electromagnetic wave induction so that the phone can be charged without a cable connection.

REMINDER

- This function allows charging two phones at the same time.
- Thick phone shells may prevent charging.
- You can use the Qi soft switching via PAD to separately activate/deactivate the wireless charging on the left or right side.
- On bumpy roads, the wireless phone charging may intermittently stop and then resume.
- Try to ensure that the surface on which a mobile phone is placed is parallel to the charging module. If the phone moves from the wireless charger area and stops charging, move it back.
- If the phone cannot be charged properly, ensure that there are no foreign objects in the wireless charging area, or wait for the wireless charging area to cool down before trying again. If it is still impossible to charge the phone, contact a BYD authorised dealer or service provider.
- After power-off, if the phone is still charging and the driver's door is opened, the instrument cluster sounds an alarm and the message "Please take your cell phone with you" is displayed for five seconds.

CAUTION

- Ensure your smart key is more than 10 in (25 cm) away from the wireless charger area when the wireless charger system is working.

CAUTION

- To avoid wireless charger dysfunction or even accidents, do not place coins, metal keys, metal rings, or other articles containing metal in the wireless charger area together with the phone.
- To avoid damage to the charger area, do not place heavy objects on it.
- If the phone wireless charger system is faulty and does not work properly, it is recommended to contact a BYD authorised dealer or service provider.
- BYD will not assume any responsibility for any problems caused by improper use. If the product is disassembled or modified, the free warranty will be terminated.
- For safety reasons, do not leave an unattended phone being charged in the vehicle.
- For safety reasons, refrain from checking phone charging status while driving.
- If a metal item is found between the device and the charger rubber pad during charging, do not remove the metal item with bare hands to prevent burning.
- For better charging, the centre of the phone coil must be aligned with the centre of wireless charger (indicated with text in the charging area).
- Prevent any fluid from coming into contact with the charger area. The wireless charger will malfunction if water enters the wireless charger via the gap around the rubber mat.



CAUTION

- Charging may stop at high temperatures, and will resume once the temperature drops.
- The wireless phone charger system can charge Qi-certified phones, and non-Qi-certified phones are not guaranteed for normal charging.
- BYD makes no commitments for problems caused by external wireless charging coils. Please use with caution.
- To avoid burning cards with chips, such as bank cards, do not place them between the phone case and the phone during charging.

06

MAINTENANCE

Maintenance Precautions.....	168
Regular Maintenance.....	172
Self-Maintenance.....	176

Maintenance Precautions

Maintenance Cycle and Items

Maintenance Plan

- The maintenance plan is designed to ensure stable driving, failure reduction, safe and economical driving.
- Drivers can refer to the maintenance plan for scheduled maintenance intervals, depending on the odometer reading or time interval, whichever comes first.
- For overdue maintenance items, the same time interval should be used for maintenance.
- Rubber hoses (for systems such as A/C, heating, and braking systems) must be checked by professional technicians according to the maintenance schedule.
- These are particularly important maintenance items whose maintenance intervals are recorded in the maintenance schedule. Hoses with any degradation or damage should be replaced immediately.
- The maintenance schedule lists all the maintenance items that are necessary to keep the vehicle in optimum condition at all times.
- It is recommended that maintenance be performed in accordance with the standards and specifications of BYD Auto Co., Ltd., and by a local BYD authorised dealer or service provider.

- The maintenance schedule lists the maintenance items and travel time or distance based on the assumption that the vehicle is used as a normal means of transportation to carry passengers and goods that do not exceed the vehicle load limit.



CAUTION

- Please maintain the vehicle regularly according to the requirements in the Warranty and Maintenance Service Manual of BYD.

Maintenance Schedule Requirements

The vehicle shall be maintained according to the regular maintenance schedule.

If the vehicle is operated primarily under one or more of the following special conditions, certain maintenance plan items may need to be performed more frequently.

- Road conditions
 - Muddy, sandy, or snowy roads.
 - Driving on dusty roads.
- Driving conditions
 - Towed trailer, camping trailer or roof rack is used.

Maintenance Schedule

Vehicle maintenance is performed based on the mileages or months, whichever comes first.

Item	Interval
Chassis screws	Check and fasten them every 12 months or 12,427 miles (20,000 km) and replace damaged parts in a timely manner.
Brake pedal and EPB switch	Check them at 12 months or 12,427 miles (20,000 km) for the first time, and every 24 months or 24,855 miles (40,000 km) afterwards, or every 12 months or 12,427 miles (20,000 km) in severe driving conditions.
Brake friction block and disc	Check them every 12 months or 12,427 miles (20,000 km).
Brake piping and hoses	Check them at 12 months or 12,427 miles (20,000 km) for the first time, and every 24 months or 24,855 miles (40,000 km) afterwards, or every 12 months or 12,427 miles (20,000 km) in severe driving conditions.
Guide pin of brake caliper assembly	Check it every 24 months or 24,855 miles (40,000 km).
Steering wheel and tie rod	Check for them at 12 months or 12,427 miles (20,000 km) for the first time, and every 24 months or 24,855 miles (40,000 km) afterwards, or every 12 months or 12,427 miles (20,000 km) in severe driving conditions.
Drive shaft boot	Check it at 12 months or 12,427 miles (20,000 km) for the first time, and every 24 months or 24,855 miles (40,000 km) afterwards, or every 12 months or 12,427 miles (20,000 km) in severe driving conditions.
Ball pin and boot	Check them at 12 months or 12,427 miles (20,000 km) for the first time, and every 24 months or 24,855 miles (40,000 km) afterwards, or every 12 months or 12,427 miles (20,000 km) in severe driving conditions.
Front and rear suspensions	Check them at 12 months or 12,427 miles (20,000 km) for the first time, and every 24 months or 24,855 miles (40,000 km) afterwards, or every 12 months or 12,427 miles (20,000 km) in severe driving conditions.
Tyre condition and pressure, incl. TPMS	Check for them every 12 months or 12,427 miles (20,000 km) and replace damaged parts in a timely manner.
Front and rear wheel alignment	Check them at 12 months or 12,427 miles (20,000 km) for the first time, and every 24 months or 24,855 miles (40,000 km) afterwards, or every 12 months or 12,427 miles (20,000 km) in severe driving conditions.
Tyre rotation (Check tyre pressure and condition at least once a month)	Check the tyre pressure and conditions at least once a month and rotate tyres every 6,214 miles (10,000 km).

Item	Interval
Door brake	Check it every 12 months or 12,427 miles (20,000 km). Remove dust from the tie rod with a wet soft cloth, apply 0.011 oz-0.028 oz (0.3-0.8 g) grease to the tie rod, riveted joints, and rotating shaft, and replace damaged parts in a timely manner.
Wheel bearing clearance	Check for it at 12 months or 12,427 miles (20,000 km) for the first time, and every 24 months or 24,855 miles (40,000 km) afterwards, or every 12 months or 12,427 miles (20,000 km) in severe driving conditions.
Coolant level in expansion tank	Check for it every 12 months or 12,427 miles (20,000 km) and replace damaged parts in a timely manner.
Drive motor coolant	Replace the long-acting organic acid coolant every four years or 62,137 miles (100,000 km), whichever comes first.
Brake fluid	Check it every 12 months or 12,427 miles (20,000 km) and replace damaged parts in a timely manner.
Brake fluid	Replace it every two years or 24,855 miles (40,000 km).
Vehicle module DTCs (to be cleared after recording)	Check for them every 12 months or 12,427 miles (20,000 km) and replace damaged parts in a timely manner.
High-voltage battery tray, shield, impact bar, and mount point torque (QH)	Check for them every 12 months or 12,427 miles (20,000 km) and replace damaged parts in a timely manner.
Battery pack capacity	Test and calibrate it every six months or 44,739 miles (72,000 km).
Check and replace the gear oil and filter screen in the transmission (NT31 precursor asynchrony/NRT36 rear-guard transmission)	Replace the gear oil and the filter at 24 months or 24,855 miles (40,000 km) for the first time, and every 24 months or 29,826 miles (48,000 km) afterwards.
Powertrain leaks or bumps	Check for them every 12 months or 12,427 miles (20,000 km) and replace damaged parts in a timely manner.
Loose high-voltage wiring harnesses and connectors	Check for them every 12 months or 12,427 miles (20,000 km) and replace damaged parts in a timely manner.
Deformation of or oil stains on the high-voltage module	Check for them every 12 months or 12,427 miles (20,000 km) and replace damaged parts in a timely manner.

Item	Interval
Foreign materials or ablation of the charging connector interface	Check for them every 12 months or 12,427 miles (20,000 km) and replace damaged parts in a timely manner.
HEPA filter*	Check it every 12 months or 12,427 miles (20,000 km), whichever comes first, and replace it if necessary. In severe driving conditions, check it every six months and replace it if necessary.
Lamp and LED lighting	Check for it every 12 months or 12,427 miles (20,000 km) and replace damaged parts in a timely manner.
Headlight dimming	Check for it every 12 months or 12,427 miles (20,000 km) and replace damaged parts in a timely manner.
Initial down tilt of low beam	Calibrate it every 6,214 miles (10,000 km).
Foreign materials on or ablation of the EPS GND point	Check for them every 12 months or 12,427 miles (20,000 km) and replace damaged parts in a timely manner.
EPS connector looseness and connector pin ablation	Check for them every 12 months or 12,427 miles (20,000 km) and replace damaged parts in a timely manner.
EPS ECU corrosion	Check for it at 12 months or 12,427 miles (20,000 km) for the first time, and every 24 months or 24,855 miles (40,000 km) afterwards.
Foreign materials or corrosion on connections between the EPS ECU and motor*	Check for them every 12 months or 12,427 miles (20,000 km) and replace damaged parts in a timely manner.
Vehicle module software update (update if any)	Check for it every 12 months or 12,427 miles (20,000 km) and replace damaged parts in a timely manner.
Wading marks on high-voltage parts	Check them every 12 months or 12,427 miles (20,000 km) and replace damaged parts in a timely manner.
Lock nut torque of wiper arm	Check for it every 12 months or 12,427 miles (20,000 km) and replace damaged parts in a timely manner.
Abrasion of shock absorber sleeve on bonnet hinge limit stud	Check for it every 12 months or 12,427 miles (20,000 km) and replace damaged parts in a timely manner.
Bonnet lock and fasteners	Check them every 12 months.
Note: When checking Item 1, replace chassis parts in a timely manner if any abnormal damage is found.	



REMINDER

- To keep the high-voltage battery in optimal condition, please fully charge and discharge the vehicle regularly, at least every six months or 44,739 miles (72,000 km), whichever comes first, for battery self-calibration. You can also contact a BYD authorised dealer or service provider for capacity testing and calibration.

Severe driving conditions include:

- Frequent driving in dusty areas or frequent exposure to salt-laden air.
- Frequent driving on bumpy, puddled, or mountain roads.
- Driving in cold weather.
- Frequent and sudden braking.
- Frequent use of a towed trailer.
- Use as a taxi.
- Driving in congested urban areas at temperatures above 90°F (32°C) for more than 50% of total travel time.
- Driving at speeds over 75 mph (120 km/h) at temperature above 86°F (30°C) for more than 50% of total travel time.
- Frequent overloading.

Regular Maintenance

Regular Maintenance

- Be sure to maintain the vehicle as per the maintenance schedule to allow it serve in the best working efficiency and reduce fault occurrence.

- Drivers can refer to the maintenance plan for scheduled maintenance intervals, depending on the odometer reading or time interval, whichever comes first.
- For overdue maintenance items, the same time interval should be used for maintenance.
- It is recommended that maintenance be performed in accordance with the standards and specifications of BYD Auto Co., Ltd., and by a local BYD authorised dealer or service provider.
- The maintenance schedule lists the maintenance items and travel time or distance based on the assumption that the vehicle is used as a normal means of transportation to carry passengers and goods that do not exceed the vehicle load limit.



CAUTION

- Please maintain the vehicle regularly according to the requirements in the Warranty and Maintenance Service Manual of BYD.

Vehicle Corrosion Prevention

The most common causes of vehicle corrosion are:

- The underbody of the vehicle is covered in salt, dust or moisture.
- The vehicle or some of its parts are exposed to high humidity and high temperature for a long time.
- The paint layer or underlayer is scratched by minor collision or by stones and gravel.

The following rules should be observed to prevent vehicle corrosion:

- Wash the vehicle frequently.
 - If driving on saline roads in winter or living in coastal areas, wash the landing area of the vehicle at least once a month, and clean the chassis and hubcap with a high-pressure water jet or steam to reduce corrosion. Wash the chassis thoroughly after winter.
- Check body paint and trims
 - Any chip or crack found on the paint must be repaired immediately to prevent corrosion. If fragments or cracks peel off from the metal surface, it is recommended to go to a BYD authorised dealer or service provider for repair.
- Check interior vehicle
 - Moisture and dust buildup under the carpet can cause corrosion. Check the undersides of carpets frequently to make sure these areas are dry.
 - Special care should be taken when transporting chemicals, detergents, fertilisers, salt, and other substances, and such substances should be kept in appropriate containers for transportation. If spillage or leakage is found, clean immediately and keep dry.
- Use fenders.
 - Fenders can protect vehicles in saline areas or on gravel roads. The bigger and closer to the ground the fender, the better.
- Park in a well-ventilated and dry area.
 - When the vehicle is not used for a long period, it should be parked in a garage or a well-ventilated place, and special body cover should be used in winter. Choose a shady place for parking temporarily.
 - Prevent strong impacts, knocks, or scratches on the paint. If the paint is scratched, dented or if it peels, it should be repaired in time, preferably by professional auto beauty provider.
 - Do not touch the paint with a greasy hand or cloth. Do not place greasy tools or rub with organic solvents on the vehicle body so as to avoid chemical reactions.
 - The vehicle must be waxed once a month or whenever water resistance performance of the vehicle degrades and be taken to an auto beauty provider for maintenance once every three months.
 - High quality polish and wax must be used. If the body finish is severely weathered, use a car cleaning polish in addition to the wax. Carefully follow the manufacturer's instructions and precautions. Chrome finish should be polished and waxed as well as painted finish.



CAUTION

- When the vehicle is repainted and placed in a high-temperature paint waxing workshop, the vehicle's plastic bumper must be removed to avoid damage caused by high temperatures.

Paint Maintenance Tips

- Do not perform secondary painting if there are no obvious scratches on the finish, so as to prevent mismatch or colour incompatibility.

Exterior Cleaning

- The vehicle must be cleaned in time under the following circumstances which will cause peeling of paint layer or corrosion of body and parts:

- Driving along the coast.
- Driving on a road on which anti-freeze has been scattered.
- Driving on roads covered with coal tar.
- Resin, bird droppings and insect carcasses get stuck.
- Driving in areas with a large amount of smoke, soot, dust, iron filings or chemicals.
- Vehicles visibly soiled by dust or mud.
- After raining.

Washing Vehicle Manually

Before washing the vehicle, park it in the shade, and wait for the vehicle to cool down sufficiently.

1. Hose off loose dirt, including all muds or road salts at the bottom of the vehicle and on wheel pits.
2. Wash the vehicle with neutral agents, the mixing of which should be carried out according to the manufacturer's instructions. Soak a soft cloth with cleaning solution and gently wipe it down along the direction of the water flow. Do not wipe in a circular motion or horizontally.
3. Rinse well: Dried washing agent forms markings. After washing the vehicle in hot weather, rinse all parts properly.
4. Dry the vehicle with a clean soft towel to prevent stay water marks. In order to prevent scratching, do not rub or apply excessive force on the paint.

REMINDER

- Do not use any alkaline washing powder, soapy water, detergents, de-waxing detergents or volatile

REMINDER

substance (gasoline, kerosene, or solvent).

- When cleaning the combination lights, do not wipe their surface with chemical solvents such as gasoline, alcohol, lacquer thinner, thinner and carbon tetrachloride. Doing so will cause the combination light casings to crack.
- It is recommended that vehicles travelling in coastal or heavily polluted areas be washed once a day.
- Do not use blades or gasoline to remove hard dirt from the vehicle body. The plastic wheel trim is easily damaged by organic matter. If any organic matter splashes on the vehicle trim, remove it with water and check whether the trim is damaged. Please replace any seriously damaged plastic wheel trim in time. Otherwise, the trim may fall from the wheel during vehicle movement and cause an accident.
- Do not use abrasive cleaning agents to scrub the bumper.
- Clean polished metal parts with carbon cleaner and wax them regularly for protection.

Automatic Vehicle Washing

When choosing an automated vehicle wash service, be aware of certain types of brushes, unfiltered rinsing water, or machine-specific rinsing procedures that may scratch the paint and affect its gloss and durability, especially darker colours. Before washing the vehicle, it is best to consult the staff of the car wash service provider to understand which washing

procedures are the safest for the paint finish.

Interior Cleaning

REMINDER

- Prevent direct water splash onto the dashboard or floor when washing the vehicle, as these may cause electrical faults.
- Do not wash the vehicle's floor.

Carpet

- Clean carpets with a good foam detergent.
- Use a vacuum cleaner to remove as much dust as possible. Several types of foam detergents can be used. Some are in spray cans, and the others are powders or liquids, which produce foam when mixed with water. Clean the carpets with foam soaked sponge or a brush, scrubbing in a circular motion.
- Do not use plain water, and keep the carpets as dry as possible.

Seat Belts

- The seat belts can be cleaned with neutral soapy water or lukewarm water.
- Scrub the seat belts with a sponge or soft cloth. Check the seat belts for excessive wear, tear, or cut marks.

CAUTION

- Do not clean the seat belt with colourant or bleach. These substances may decrease the seat belt's strength.

CAUTION

- Do not use any seat belt that is not dry.

Doors and Windows

- Doors and windows can be cleaned with any ordinary detergent.
- Check the door brakes regularly. If a door brake lever is found with visible dust accumulation, wipe it with a wet soft cloth.

CAUTION

- When cleaning the inside of the rear windows, take care not to scratch or damage electric heating wires or junctions.

A/C Control Panel, Car Speakers, Dashboard, Control Panel and Switches

- Clean the A/C control panel, car speakers, dashboard, control panel and switches with a wet soft cloth.
- Wipe dust off gently with a clean soft cloth soaked in lukewarm water.

CAUTION

- Do not use organic substances (for example, solvents, kerosene, alcohol, and gasoline) or acid or alkali solutions. These chemicals can cause discolouration, staining, or flaking.
- Please confirm that the detergent or polishing agent to be used does not contain the above substances.
- If a new liquid washing agent is used, do not splash it onto the interior surface of the vehicle, because it may contain the above

 **CAUTION**

substances. If there is any spillage, immediately clean it thoroughly.

Leather

- Leather trimmings can be cleaned with a neutral detergent for woolen.
- Use a soft cloth with a neutral detergent solution to wipe off the dust, and then use a clean, wet cloth to wipe the remaining detergent thoroughly.
- If leather gets wet, wipe it with a clean soft cloth and air dry it in a cool, ventilated place.
- For any questions about vehicle cleaning, please consult a local BYD authorised dealer or service provider.

 **CAUTION**

- If dirt cannot be cleaned off using a neutral detergent, clean it with a detergent that does not contain organic solvents.
- Do not clean leather with any organic material such as volatile oil, alcohol, gasoline, acid or alkali, as these will cause discolouration.
- Do not clean leather with a nylon brush or synthetic fiber cloth, as these may scratch the fine patterns on the leather surface.
- Mold may grow on dirty leather trimmings. Special care must be taken to avoid oil stains and trimmings must always be kept clean.
- Prolonged exposure to sunlight will cause leather to harden or shrink, so the vehicle should be parked in a shady and cool place, especially in the summer.

 **CAUTION**

- In hot weather, avoid placing vinyl or waxy items on the trimmings, as these may stick to leather in high temperatures.
- Improper cleaning of leather trimmings may cause discoloration or spots.

Self-Maintenance

Self-Maintenance

Self-Maintenance Precautions

- If maintenance is to be carried out by the owner, be sure to follow the correct steps specified in this section.
- Note that improper and incomplete maintenance will affect the good use of the vehicle.
- This section only lists instructions on simple maintenance items that can be done by the owner. However, there are many items that must be done by qualified technicians with special tools.
- Special care must be taken in maintaining vehicles to prevent accidental injuries. Make sure to obey the followings:

 **CAUTION**

- Beware of short circuits, as some circuits and vehicle components carry high current or voltage.
- If coolant overflows, wipe it with a dry cloth or tissue to prevent damage to components or vehicle paint.

CAUTION

- If brake fluid overflows, rinse it with water to prevent damage to components or vehicle paint.
- When replacing wiper blades, do not allow the wipers to scratch the glass surface.
- Before closing the bonnet, check whether any tool or wipe cloth is left in the engine compartment.
- When working inside or under the vehicle, always wear goggles to protect your eyes against flying or falling objects or splashing liquid.
- As brake fluid may damage the skin or eyes, be careful when filling it. If your skin or eyes are exposed to brake fluid, immediately flush with clean water. Seek medical attention immediately if discomfort persists.

Checks

The following items should be checked according to usage or specified mileage:

- Coolant level - Expansion tank coolant level should be checked at each charge.
- Windscreen washer fluid - The residual amount of washer liquid in the tank should be checked monthly. When washer liquid is frequently used, the residual amount of liquid should be checked at each charge.
- Windscreen wiper - Check wiper conditions monthly. If the wiper does not work, check it for wear, cracking, or other damage.
- Brake fluid level - Check the level monthly.

- Brake pedal - Check whether the brake pedal is operating properly.
- EPB switch - Check whether the switch is functional.
- Low-voltage battery: Check the battery and terminals condition for corrosion monthly.
- A/C system: Check the operation of A/C units weekly.
- Tyres - Check tyre pressure monthly. Check tread wear and whether there are foreign bodies embedded.
- Windscreen defrosters: Check the defroster vent monthly.
- Lights - Check the condition of headlights, position lights, tail lights, high mount brake light, turn signals, rear fog lights, brake lights and license plate light monthly.
- Doors - Check whether the boot lid and all other doors (including rear doors) can be opened freely and locked securely.
- Horn - Check whether the horn is functioning properly.

REMINDER

- Do not continue driving a vehicle that has not been inspected, as this may result in serious vehicle damage and personal injury.

Combination Lights**Front left combination lights**

- Front combination lights are aligned before vehicle delivery. If the vehicle carries heavy load frequently, front combination lights may need to be realigned. It is recommended to have the front combination lights aligned by a BYD authorised dealer or service provider.

Fogging of lights

- Combination lights, tail lights, and turn signals on the side mirrors may become foggy after heavy rain or cleaning. This is similar to condensation on the side window during rain. It does not mean any problem with your vehicle.
- The lights are a relatively enclosed and narrow space. The temperature is very high when they light up (the mask and reflector could be burned and deformed easily), so they need heat dissipation. There are heat dissipation holes on the lamp housing for convection. The greater the temperature difference is, the more active the convection is. During the convection, the moisture in the air inevitably enters a lamp. Factors such as exposure to sunlight, convection, and bulb heating can cause the moisture in the air to condense into fog or water beads easily on the lamp surface at low temperatures. This is called fogging of lights.

REMINDER

- If fog presents inside the headlight and inside the turn signal on the side mirror, it may be due to high air humidity or significant temperature difference between the vehicle and its surroundings. In that case, turn on the headlight or turn signal while driving. The fog will evaporate after a short period of driving.
- If there is a noticeable amount of water inside the lights, it is recommended to drive the vehicle to a BYD authorised dealer or service provider for maintenance.

Vehicle Storage

- If the vehicle needs to be parked for a long time (more than a month), the following preparations should be made. Proper preparation helps prevent degradation and ensure easy use of the vehicle. If possible, park the vehicle indoors.
- Charge the vehicle on time.
- Thoroughly clean and dry the body surface.
- Clean the interior of the vehicle to ensure that carpets and mats are completely dry.
- Release the parking brake and set the gearshift lever in parking gear.
- Open one window slightly (if the vehicle is stored indoors).
- Disconnect the low-voltage battery's negative terminal.
- Pad the front wiper arm with a folded towel or cloth to keep it out of contact with the windscreen.
- To reduce adhesion, apply silicone lubricant to all door seals and body wax to the painted surface where the door seals meet.
- Cover the vehicle body with a breathable covering made of a "porous material", such as cotton. Non-porous materials, such as plastic sheeting, can build up moisture and damage the paint.
- If possible, start the vehicle regularly (preferably monthly). If the vehicle has been parked for a year or more, go to a BYD authorised dealer or service provider for comprehensive maintenance.

Bonnet

Opening the Bonnet

1. Pull the handle on the right under the dashboard twice. The bonnet unlocks and opens slightly.



2. To open the bonnet:

- Raise the bonnet to an appropriate height; then it will automatically rise to the open state.



3. To close the bonnet:

- Pull down the bonnet, and press it with force by hand to close it.



4. After closing the bonnet, check whether the latch is securely locked.

! REMINDER

- Ensure that the bonnet is closed and locked firmly. Otherwise, the bonnet may suddenly open during driving, resulting in an accident.
- Do not force down the bonnet or release it from a high position.

Cooling System

- It is required that the liquid level should be between the Maximum (MAX) and Minimum (MIN) marker lines of the expansion tank.
- The coolant must always be of the same specification as the original, without adding any mixture. Different brands and types of refrigerant should not be mixed.



- Refill coolant to the MAX line if the level is below the MIN line. Check the cooling system for leakage.

REMINDER

- Opening the coolant expansion tank when the motor has not yet fully cooled down may cause coolant to squirt out, resulting in severe burns.

CAUTION

- Do not add any rust inhibitor or other additives to the cooling system for they may be incompatible with the coolant or the motor components.
- Before opening the reservoir cap, make sure that the motor, high-voltage electronic control assembly, refrigerant reservoir and radiator are all cooled down.

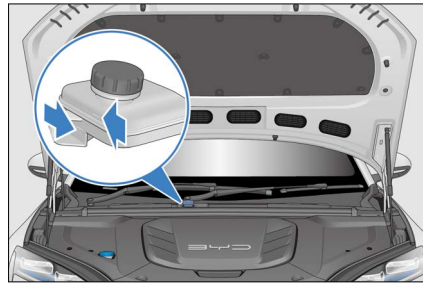

Washer

- During normal use, check the liquid level of the windscreen washer reservoir at least monthly.
- If the windscreen washer is used frequently, the level of the washer reservoir should be checked more frequently.
- High quality windscreen washer fluid should be added to improve stain removal and prevent freezing in cold weather.

Braking System

- Check the level in the fluid tank monthly, and change the brake fluid according to the travel time and mileage specified in Maintenance Schedule.
- Be sure to use the brake fluid of the same specifications as the original brake fluid, and different types of brake fluid should not be mixed.
- It is required that the level in the fluid tank should be between "MAX" (maximum level) and "MIN" (minimum level) marks.
- If the level is below the MIN mark, check if the braking system leaks and the brake friction blocks are worn.

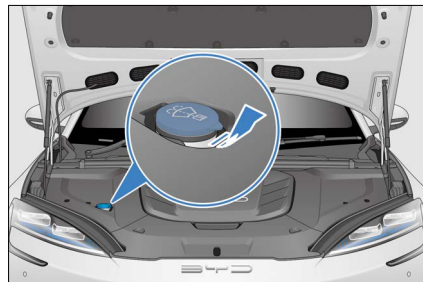

- When refilling the washer fluid, use a clean cloth dipped in the windscreen washer fluid to clean the windscreen wiper blade, thus helping keep the wiper blade in good condition.

CAUTION

- Do not inject vinegar-water solution into the windscreen washer fluid reservoir.



CAUTION

- It is recommended to use certified windscreen washing fluid.

A/C System

- The A/C system is a closed system, and any important maintenance work should be performed by professionals from a BYD authorised dealer or service provider.
- The following practices help ensure that the A/C system works effectively.
 - Check the radiator and A/C condenser regularly.
 - Remove leaves, insects, and dust from the front surface of the A/C system. These deposits hinder the air flow and reduce the cooling effect.
 - In cold months, turn the A/C on once a week for at least 10 minutes to circulate the lubricating oil in the refrigerant unit.
- If A/C cooling efficiency decreases, go to a BYD authorised dealer or service provider for maintenance.



CAUTION

- Whenever the A/C system is maintained, the maintenance station should use a refrigerant recycling system. The system can recycle refrigerant to avoid environmental pollution caused by directly discharging refrigerant.

Wiper Blades

The blade strip, made of synthetic rubber, is a vulnerable part. Various service environment of the vehicle and usage habits of drivers can damage the blades.

Therefore, please observe the following to ensure the service life of blades and driving safety:

- Do not use a blade to remove ice from the windscreen surface. Use a customised ice scraper.
- Do not scrape the windscreen surface if it is dirty, greasy or waxy.
- Keep the windscreen surface clean. Do not scrape dust, sand, insects, or foreign bodies on the windscreen surface.
- During vehicle washing and body paint maintenance, there is no need to wax the windscreen, as the wax layer reflects light in bad light, affecting the line of sight and driving safety. After washing the vehicle, rinse the blade with plain water, and use special windscreen wax cleaner to remove the wax layer on the windscreen.
- To prevent excessive water pressure from damaging the blades, do not wash the blades directly with a water jet.

Maintenance Rules

- Clean windscreen and blade regularly (preferably once a week or once every two weeks).
- Wipe the wiper regularly (preferably once a day or once every two days). When using a blade to wipe the windscreen, keep the windscreen fully wet. (When there is no rain, the washer liquid must be sprayed in advance).
- Clean the windscreen with a special windscreen washer fluid.
- Promptly clean mud and insect carcasses stuck to the windscreen with a rag.
- When there are marks on the windscreen caused by gravel,

maintenance must be carried out timely. (It is recommended that windscreen repair resin products should be used and the windscreen should be replaced if marks are too large or too many.)

- Replace the wiper blades regularly, preferably once every six months.
- When cleaning the windscreen, raise the wiper arm in advance. The specific operation method is as follows:
 1. Go to infotainment touchscreen →  → **Vehicle health** → **Overhaul** to enable front wiper maintenance. The wiper is then rotated down.
 2. Grasp the upper end of the wiper arm and carefully lift the wiper arm and blade assembly.

Tyres

- For safe driving, tyres must be made and sized to fit the vehicle, with good tread and standard tyre pressure.
- The following pages provide details on how to check tyre pressure, damage to and wear of tyres, and the operating method for tyre transposition.

WARNING

- Using tyres with excessive wear or insufficient/excessive pressure can result in accidents, severe injury, or death.
- Please follow all instructions in this manual regarding tyre inflation and maintenance.

Tyre Inflation

- Keep tyres properly inflated to provide the best combination of

maneuverability, tread life, and driving comfort.

- Under-inflated tyres can cause uneven tyre wear, affect steerability and energy consumption, and are prone to leakage due to overheating.
- Over-inflated tyres reduce riding comfort and are prone to damage from uneven roads. In severe cases, the risk of tyre bursting poses severe threats to the safety of the entire vehicle. Over-inflation will also cause uneven wear and tear of tyres, affecting tyre service life.
- When tyres are cold, you can decide whether to replenish tyre pressure according to the tyre pressure values displayed on the instrument cluster.
- Tyre pressure should be measured while tyres are at ambient temperatures. This means that it should be measured at least three hours after stop. If you must drive the vehicle before the tyre pressure is measured, tyres can still be considered at ambient temperature as long as the travelled distance is not more than 1 mile (1.6 km).
- It is normal that tyre pressure reading measured while tyres are hot (after travel of several miles) is 0.3-0.4 bar (30-40 kPa) higher than when tyres are cold. In that case, do not deflate tyres in order to achieve the specified cold tyre pressure reading; otherwise, the tyre pressure will be insufficient.

REMINDER

- The recommended cold tyre pressure is indicated on the label affixed to the driver's door frame.
- Tubeless tyres have a self-sealing function when they are punctured. However, as the leak

! REMINDER

is usually very slow, as soon as the tyre begins to depressurise, carefully look for the leak location.

Checks

- Whenever checking tyre inflation, check tyres for damage, foreign body piercing, and wear.
 - Replace the tyre if bumps, or tread or side damage are found. Tyres must be replaced if any of the case happens.
 - Replace the tyre if there are cracks on its side, or if its fabric or cord can be seen.
 - Replace tyres with excessive tread wear.

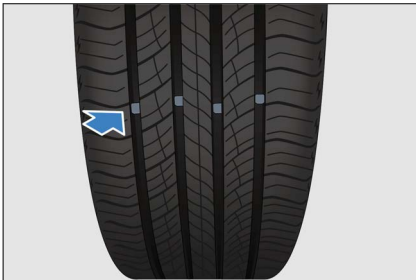

- Tyre treads are cast with wear bars. When the tread is even with the wear bar, its thickness is less than 0.06 in (1.6 mm). The adhesion of tyres worn to this extent is very small on wet roads.
- Tyres with exposed wear bars are experiencing serious performance loss and therefore must be replaced.

Maintenance

- In addition to proper inflation, proper wheel alignment also helps reduce tread wear.
- If uneven tyre wear is found, go to a BYD authorised dealer or service provider and check the wheel alignment.
- The vehicle has been balanced in the factory, but tyres need to be re-balanced after driving for a period of time.
- If there is some kind of continuous vibration while driving at high speeds (above 50 mph (80 km/h)), but not at low speeds, go to a BYD authorised dealer or service provider and check the tyres.
- If a tyre has been repaired, be sure to re-balance it.
- When installing a new tyre or replacing a new wheel, always perform tyre balancing.

! CAUTION

- Improper wheel balancers can become loose and fall off, which damages the vehicle or surrounding objects during vehicle travel.
- Improper wheel balancers damage the aluminium rims of the vehicle. Therefore, it is recommended to use original wheel balancers.

Tyre Rotation

- In order to make tyres wear the same and prolong their service life, it is recommended to rotate tyres every 6,214 miles (10,000km) and conduct four-wheel alignment, inspection and adjustment as well.

- When purchasing replacement tyres, you may find that some tyres are "directional," which can only be rotated in one direction. If directional tyres are used, only the front and rear wheels can be swapped in tyre rotation.

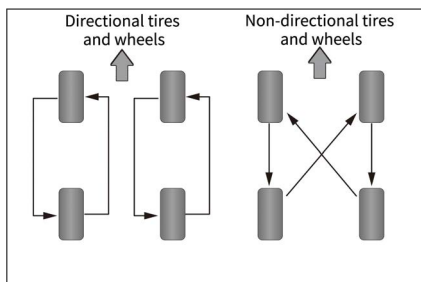

Tyre and Wheel Replacement

- Original tyres maximise performance, while providing the best combination of maneuverability, driving comfort and service life.
- Go to a BYD authorised dealer or service provider for replacement of original tyres.
- Replacement of tyres with different sizes, road ranges, rated speeds and maximum cold pressures (marked on the tyre side) or mixed use of radial tyres and diagonal tyres can reduce braking ability, driving force (ground adhesion) and steering accuracy.
- The installation of unsuitable tyres can affect the maneuverability and stability of the vehicle, and may lead to accidents.
- Do not replace only one tyre, otherwise it will seriously affect the maneuverability of the vehicle.
- ABS works by comparing wheel speed. When replacing a tyre, use a tyre of the same size as the original tyre. The size and structure of the tyre can

affect wheel speed and may lead to uncoordinated system operation.

- If the wheel needs to be replaced, ensure that the specifications of the new wheel match those of the original wheel. New wheels are available for purchase at a BYD authorised dealer or service provider. Please consult a BYD authorised dealer or service provider before replacing the wheels.

! REMINDER

Please observe the following precautions to ensure proper vehicle maneuverability and control.

- Do not mix radial tyres, bias belted tyres, or diagonal ply tyres on the vehicle.
- Do not use tyres with dimensions other than those recommended by the manufacturer.

Fuses

All vehicle circuits are provided with fuses to prevent short circuit or overloading. These fuses are mounted in the under-bonnet and dashboard PDBs, respectively. Fuse labels are included in these PDBs, showing the correspondence of fuses with electrical components.

① Under-bonnet PDB

② Dashboard PDB

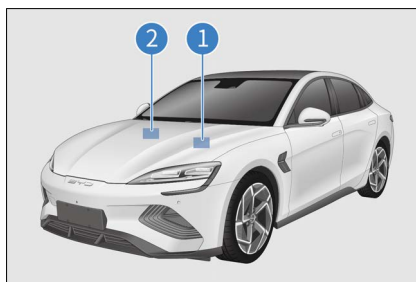

- The fuses under the bonnet are located at the left rear part in the engine compartment. To open it, remove the trim first, and press the latch.
- The dashboard fuse under the driver's side is located on the right side of the dashboard. Take apart the lower body of the dashboard to check the fuse.
- Replacement of blown fuses with ones of higher amperage can significantly increase the likelihood of damage to the electrical system.
- If there is no spare fuse of the same amperage, use a fuse with lower amperage instead.

! REMINDER

- Do not use fuses with amperage higher than the rated ampere value or any other solution to replace the fuses, as this can cause serious damage or even a fire.
- If a fuse blows, it is recommended to check or replace the fuse at a BYD authorised dealer or service provider.

Under-Bonnet PDB Nameplate

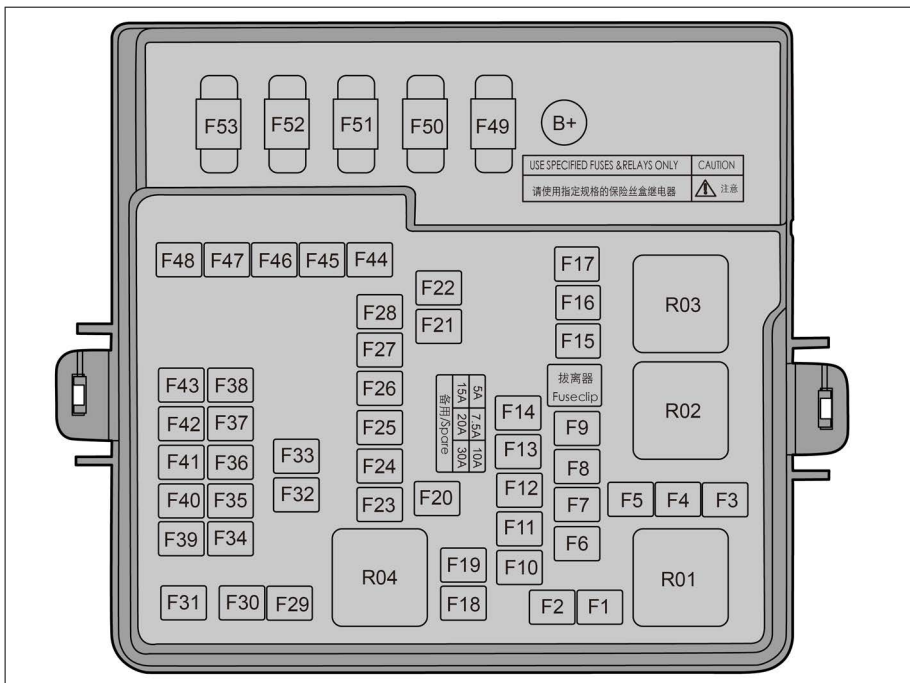

No.	Ampere (A)	Protected Component or Circuit
F1	-	-
F2	25	External amplifier

No.	Ampere (A)	Protected Component or Circuit
F3	-	-
F4	-	-
F5	-	-
F6	-	-
F7	-	-
F8	-	-
F9	7.5	Battery manager
F10	15	Electrically controlled cooling water pump
F11	10	Electrically controlled cooling water pump
F12	-	-
F13	-	-
F14	-	-
F15	10	ADAS
F16	40	Low speed fan
F17	-	-
F18	-	-
F19	-	-
F20	20	Vehicle controller
F21	30	Front wiper
F22	30	Rear defroster
F23	20	Rear electronic fuel pump
F24	10	Compressor
F25	10	Motor controller
F26	7.5	E-Call
F27	15	Auxiliary power
F28	15	USB
F29	30	Left front power seat
F30	60	ESC

No.	Ampere (A)	Protected Component or Circuit
F31	20	Front electronic fuel pump
F32	30	Right front power seat
F33	10	Integrated thermal management module
F34	15	Heater
F35	5	Rear body control module
F36	10	ADAS
F37	7.5	ADAS
F38	10	SRS
F39	-	-
F40	7.5	ETC
F41	5	EPS
F42	5	ESC
F43	7.5	Suspension module
F44	60	ESC
F45	40	Blower
F46	15	USB
F47	-	-
F48	-	-
F49	125	DP-EPS
F50	-	-
F51	60	Electric fan
F52	-	-
F53	-	-

Dashboard PDB Nameplate

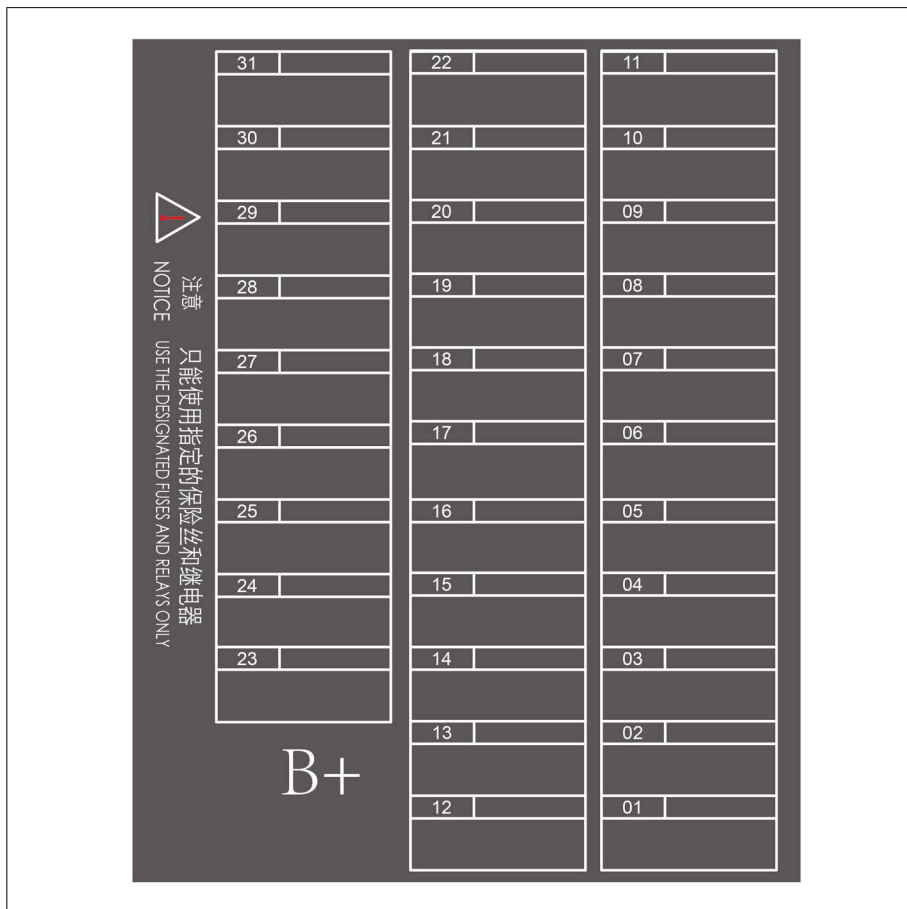

No.	Ampere (A)	Protected Component or Circuit
01	30	Rear body control module
02	30	Rear body control module
03	10	Wireless charger
04	10	Diagnosis port
05	7.5	HUD
06	5	High-frequency receiving module
07	5	Gearshift panel

No.	Ampere (A)	Protected Component or Circuit
08	20\15	Infotainment system
09	5	Brake light switch
10	30	Rear body control module
11	7.5	Combination switch
12	30	Constant power
13	25	External amplifier
14	30	Intelligent driving
15	30	Intelligent driving
16	15	HV all-in-one controller
17	15	HV all-in-one controller
18	15\25	Suspension module
19	25	Front left window
20	25	Right front window
21	25	Rear left window
22	25	Right rear window
23	15	CCS communication convertor
24	10	Alcohol interlock
25	1.5	E-Call
26	-	-
27	-	-
28	-	-
29	-	-
30	-	-
31	-	-

 **REMINDER**

- Fuse amperage (such as the amperage of infotainment system fuse) may vary across vehicle

 **REMINDER**

configurations. Maintenance and replacement must be based on the actual configuration.

07

WHEN FAULTS OCCUR

When Faults Occur.....192

When Faults Occur

Reflective Vest

! REMINDER

- If the vehicle breaks down and an emergency stop is needed, promptly put on the reflective vest.

If Smart Key Battery Is Exhausted

If the smart key indicator does not flash and the vehicle cannot be started using the start function, the smart key battery may be exhausted. It is recommended to contact a BYD authorised dealer or service provider for battery change as soon as possible. In this case, you may start the vehicle in no-power mode.

! CAUTION

- Do not expose the smart key to high temperatures.
- Do not hit or slam the key with hard objects.
- Keep the key away from magnetic fields.
- After locking the vehicle and arming its anti-theft alarm system, keep the key away from the vehicle if you do not use the vehicle; otherwise the automatic card finding of the vehicle will consume the low-voltage battery.

1. Use the mechanical key to unlock the vehicle.
2. Press the brake pedal and the START/STOP button. The smart key warning

light comes on and the speaker in the vehicle gives a beep.

3. Keep the smart key close to the no-power mode sign on the auxiliary dashboard within 30 seconds after the speaker beeps. The speaker beeps again, the smart key warning light turns out, and the vehicle can be started.

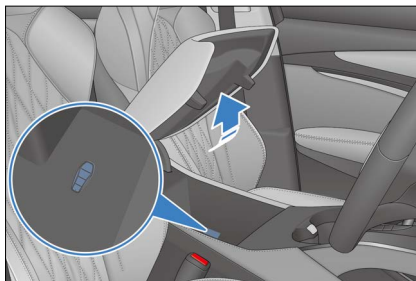

- The no-power mode sign is located in the cubby box.
4. Start the vehicle within five seconds after the speaker beeps again.

Emergency Shutdown System

- The emergency shutdown system is activated and the high-voltage system is automatically shut down when the following conditions are met:
 - The airbags do not deploy after a frontal collision.
 - There is a rear collision.
 - The vehicle system is faulty.
- If any of the above collisions and vehicle system failures occur, the OK indicator will go off.
- Activating the emergency shutdown system in the noted types of collision minimises the risk of injuries or accidents.

- The vehicle system cannot be switched into the OK status once the emergency shutdown system is activated. In that case, it is recommended to contact a BYD authorised dealer or service provider for help. Even if the ignition switch is set to the OK position, the system will be turned off immediately. Contact a BYD authorised dealer or service provider as soon as possible.

Vehicle Fire Rescue

In case of fire, continue to operate the vehicle as follows according to the actual situation:

1. Switch the ignition off, and leave the vehicle.
2. On the precondition that personal safety is ensured, if the fire is small and slow, use a dry powder fire extinguisher to put out the fire, and call for help immediately.
3. If the fire is large and growing quickly, stay away from the vehicle and wait for rescue.

CAUTION

- Wear insulated gloves during vehicle disassembly. Use fire extinguishers of designated type. Water or incorrect fire extinguishers may cause electric shock.
- In the event of other special conditions that cause flying projectiles (such as interior trims and glass), stay away from the vehicle and promptly ask a BYD authorised dealer or service provider to come to the site for handling.

Battery Leakage Rescue

After a collision, if there is battery leakage, an acrid smell inside the vehicle, visible acid flow outside the vehicle, or any smoke with the battery pack:

1. Switch the ignition off and disconnect the low-voltage battery under the left rear seat if conditions permit.
2. It is recommended to call immediately a BYD authorised dealer or service provider for rescue.

If a Collision Occurs

In case of collision, operate the vehicle as follows according to the actual situation:

1. Switch the ignition off, and disconnect the low-voltage battery if conditions permit.
2. Call immediately a BYD authorised dealer or service provider for rescue.
3. Carry out a simple inspection, if conditions permit: Check whether any edge of the high-voltage battery tray is cracked and whether any obvious liquid flows out.
 - If skin comes in contact with leaked fluid, wash it immediately with plenty of water for 10-15 minutes. If there is still any discomfort, apply 2.5% calcium gluconate ointment, or soak in 2% to 2.5% calcium gluconate solution. If the condition does not get better or discomfort persists, seek medical help immediately.

WARNING

- Do not touch any spilled liquid, and stay away from a leaking vehicle or high-voltage battery.

WARNING

- Do not dispose of the leaked fluid into the water or soil or other environment.
- The vehicle system operates with high-voltage DC power. It generates a lot of heat before and after vehicle start-up and when the vehicle is powered off. Watch out for high pressures and high temperatures.
- Do not disassemble, move, or alter high-voltage battery components and connecting cables as their connectors can cause serious burns or electric shock and may result in personal injury or death. The orange cables are part of high-voltage wiring harness. Users must not repair the vehicle's high-voltage system by themselves. If any repair is required, it is recommended to go to a BYD authorised dealer or service provider.
- The remote control key and high-voltage components of the vehicle may affect and harm people carrying medical devices.

If the Vehicle Needs Towing

If the vehicle needs towing, it is recommended to contact a BYD authorised dealer or service provider, a professional towing service, or the organisation you joined for roadside assistance.

CAUTION

- The vehicle must not be towed by other vehicles using only ropes or chains.

Common towing methods include:

- Flatbed device
 - When the vehicle is faulty and needs towing, a flatbed trailer is the best choice. This is because leaving a single front or rear wheel on the ground can cause damage to high voltage components, and leaving a single front or rear wheel of the vehicle in power-up mode on the ground can cause loss of driver assistance system sensor calibration.

REMINDER

- When moving a vehicle on a flat trailer, make sure that the vehicle being moved is properly secured to prevent it from sliding back.

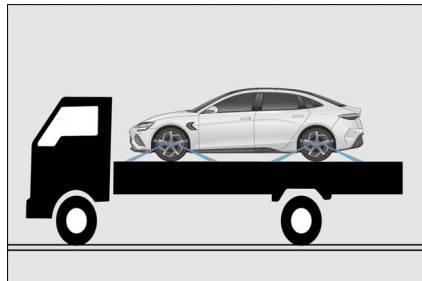

Tow Hook

The installation point of vehicle tow eye is shown in the illustration.

1. Press to start.
2. Install the tow eye in the tow eye opening.



! CAUTION

- Towing the vehicle with a tow eye is not recommended. Please see Tow Hook method.
- Only the in-vehicle tow eye can be used. Otherwise, your vehicle will be damaged.
- Do not tow the vehicle from the rear with four wheels staying on the ground, otherwise it may damage the vehicle.

If a Tyre Goes Flat

- Keep straight and move off the road to a safe place. Drive the vehicle off the busy road to a safe place. Park on solid, flat ground and avoid motorway forks. Park on solid, flat ground.
- Please refer to the followings to operate when parking:
 1. Depress the brake pedal to stop the vehicle smoothly, and then press the P button to switch to P mode. In such case, the P gear indicator on the instrument cluster goes on.
 2. Press START/STOP button.
- Power off the vehicle and turn on the hazard warning light.
- Be sure to have all passengers get off the vehicle and ask them to go to a safe place away from crowded traffic.

- To prevent slipping, secure the vehicle by wedging the tyre diagonally against the flat tyre.

! CAUTION

- Do not continue driving with a flat tyre. Even a short distance of driving with flat tyre can cause irreparable damage.

In-Vehicle Tools

- These tools are stored in a tool box under the boot cover flap.
- ① Warning triangle
 - ② Reflective vest
 - ③ Lug nut cover removal clamp
 - ④ Using tyre repair device
 - ⑤ Tow hook

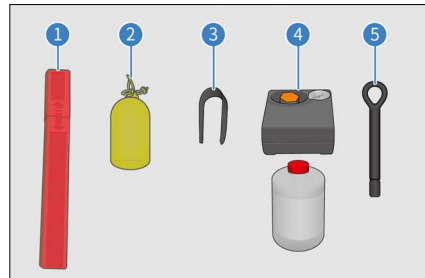

- In an emergency where you need to service the vehicle yourself, you must know how to use these in-vehicle tools and their locations.

Placing the warning triangle

! REMINDER

- When parking for repair, remember to place the red triangle side facing oncoming vehicles, 328 - 656 ft (100-200 meters) away from the vehicle.

! REMINDER

After the repair, recover the warning triangle for future use.

The warning triangle is used to warn drivers of vehicles coming from behind and to avoid risk of collision with the vehicle ahead being parked or repaired due to high speed or late braking.

How to use the warning triangle:

1. Take the warning triangle out of its box.
2. Open the warning triangle to form a closed triangle.
3. Release its supports to create a pattern as shown.

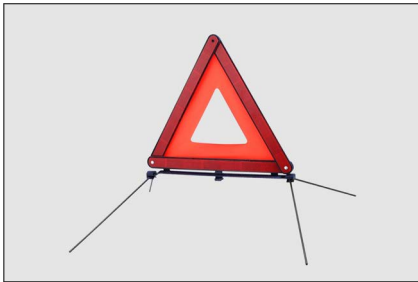

Using Tyre Repair Kit

- The tyre repair kit is used to seal small cuts, especially cuts in tread pattern. It is just an emergency solution for you to drive to the nearest service centre, and only for short emergency stretches, even if the tyre is not deflated.

! WARNING

- The tyre repair kit is only suitable for minor damages of tyres. If a wheel is damaged, tyre puncture sealant kit is prohibited.

! WARNING

- Tyre sealant is highly flammable and harmful to health. Take necessary precautions to prevent fire and avoid contact with skin, eyes, and clothing; keep it away from children; and do not inhale its vapour.

In case of contact with tyre sealant:

- If tyre sealant comes into contact with the skin or gets into the eyes, thoroughly flush the affected body part immediately with plenty of clean water.
- Change contaminated clothing immediately.
- In case of an allergic reaction, seek medical attention immediately.
- If tyre sealant is ingested by accident, rinse mouth thoroughly and drink plenty of water immediately. Do not induce vomiting, but seek medical attention immediately.

Using the tyre repair kit

- Refer to labels on the inflator and tyre sealant for usage of the kit.
- If the inflator needs to be connected to a power source, plug the inflator into the vehicle's 12V socket, start the vehicle, and switch on the inflator. The tyre sealant is then filled through the inflator hose into the tyre along with air.

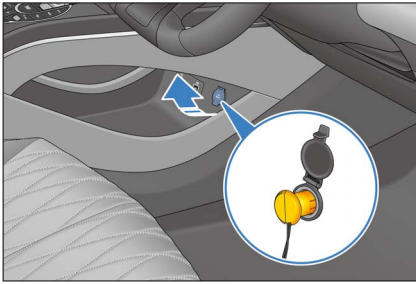

! REMINDER

- Make sure the inflator switch is off when plugging the power supply into the 12V socket in the vehicle.
- The inflator can only be turned on for up to 10 minutes.
- Observe the tyre pressure reading on the inflator.
 - If the tyre pressure does not reach 1.8 bar (180 kPa) within 10 minutes (red area shown in the figure), turn off the inflator. You are recommended to contact a BYD authorised dealer or service provider.

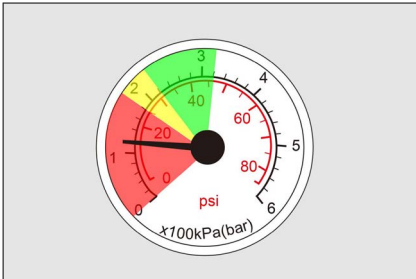

- If the tyre pressure reaches between 1.8 and 3.2 bar (180 and 320 kPa) (green and yellow areas shown in the figure), remove the kit as soon as possible and drive at a speed below 50 mph (80 km/h) within one minute, with the furthest driving distance not exceeding 6 miles (10 km), so that

the tyre sealant is evenly distributed within the tyre.

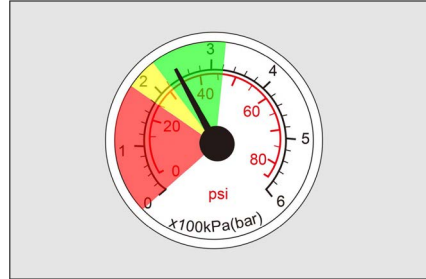

- Stop to check the repaired tyre and the tyre pressure reading on the inflator.
 - If the tyre pressure is greater than 2.2 bar (220 kPa), drive to the nearest service centre at a speed below 50 mph (80 km/h).
 - If the tyre pressure is 1.3-2.2 bar (130-220 kPa), repeat the process to fill the tyre sealant into the tyre and observe the tyre pressure gauge reading on the inflator.
 - If the tyre pressure does not reach 1.3 bar (130 kPa), it is recommended to contact a BYD authorised dealer or service provider.

! REMINDER

- Using tyre repair kit on damaged tyres is only an emergency solution. Please change the tyres at a professional repair centre as soon as possible. It is recommended that you contact a BYD authorised dealer or service provider and inform the maintenance technician that the tyre sealant has been used.
- After using the tyre repair device, it is recommended to purchase new tyre sealant at a BYD authorised dealer or service provider.

REMINDER

- Avoid hard acceleration and high-speed turns.
- Do not exceed the 50 mph (80 km/h) maximum speed limit and replace flat tyres as soon as possible. Do not drive further if the vehicle experiences strong vibration, unstable performance, or noise.
- When the tyre sealant is about to expire (see the label on the canister for exact date), replace it with a new one.

If the Low-Voltage Battery Is Exhausted

When the vehicle cannot start due to under voltage of low voltage distribution box, try to start it as per the following steps:

1. Open the bonnet.
2. Remove the left trim panel of the engine compartment.
3. Connect one end of the red positive (+) cable to the positive (+) terminal of the undercharged low voltage distribution box of the vehicle under rescue.

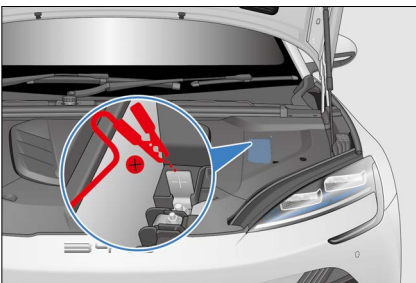

4. Connect the other end of the red positive (+) cable to the positive (+)

terminal of the charged low voltage distribution box of the rescue vehicle.

5. Connect one end of the black negative (-) cable to the negative (-) terminal of the charged low voltage distribution box of the rescue vehicle.

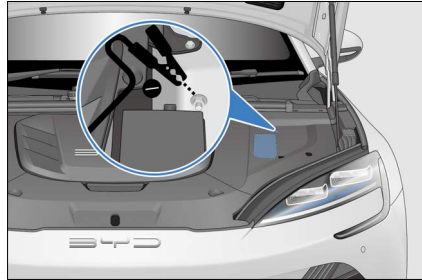

6. Connect the other end of the black negative (-) cable to an applicable tie point (clean, unpainted, solid and grounded metal part) of the vehicle under rescue.

7. Start the rescue vehicle and keep it running for a while. Then try to start the vehicle under rescue.

8. After the vehicle under rescue starts normally, turn off the power of the rescue vehicle, remove the jumper cables orderly reverse to connection, and put them away.

9. Install the bonnet trim panel, and close the bonnet.

WARNING

- Connecting or disconnecting jumper cables in the wrong order may lead to an electrical short circuit, resulting in vehicle damage or personal injury.
- To prevent a short circuit in the jump start, jumper cable clamps shall not contact each other or any conductive material other than the jumper points.

⚠ CAUTION

- If the vehicle being rescued cannot be started after several attempts, contact a BYD authorised dealer or service provider.
- The battery rated voltage of the rescue vehicle for jump start shall be 12V.

⚠ WARNING

- Make sure that the lifting or jacking is stable and secure to prevent vehicle damage and personal injury.
- When jacking up the vehicle, do not have any part of your body under the vehicle.

If the Vehicle Needs Support

If the vehicle needs to be lifted or jacked, the lifting arm or jack can only be placed at the lifting points as shown in the figure.

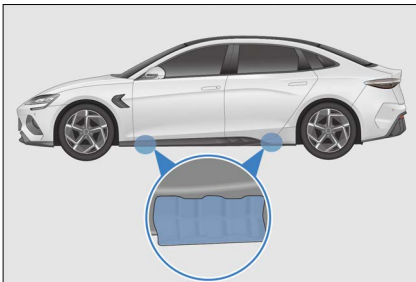

- Pay attention to the followings when lifting or jacking the vehicle to ensure safety:
 - Park on solid and flat ground.
 - Switch the ignition off, and all the occupants must get off the vehicle.
 - In case of vehicle slipping, a block should be placed in front of the front wheel or behind the rear wheel when it is jacking up.

⚠ WARNING

- Do not place the lifting arm or jack on the high-voltage battery.

08

SPECIFICATIONS

Data.....	202
Tips.....	205
Declarations of Conformity.....	208

Data

Vehicle Parameter

Basic parameter

Item	Parameter
Number of occupants	5 persons
Length	189 in
	4800 mm
Width (excluding side mirrors)	74 in
	1875 mm
Height	57 in
	1460 mm
Wheelbase	115 in
	2920 mm
Front track	64 in
	1620 mm
Rear track	64 in
	1625 mm
Front overhang	35 in
	885 mm
Rear overhang	39 in
	995 mm
Approach angle	13°
Departure angle	14°

Drive motor

Item	Parameter
Model	Rear drive extended range AWD
Drive motor model	Rear control module: TZ200XYC Front control module: YS210XYA

Item	Parameter	
		Rear control module: TZ200XYC
Drive motor type	Permanent magnet synchronous motor	Front: AC asynchronous motor Rear: Permanent magnet synchronous motor
Drive type	Rear control module	AWD

Vehicle power performance and economic efficiency

Item	Parameter	
Model	Rear drive extended range	AWD
Max. design speed	112 mph	112 mph
	180 km/h	180 km/h
Max. gradeability (%)	≥30	≥50

High-voltage battery

Item	Parameter
Type	Lithium iron phosphate battery
Rated capacity (Ah)	150

Wheels and tyres

Item	Parameter
Tyre specification	225/50R18; 235/45R19
Tyre pressure	Front/Rear: 2.5/2.9 bar
	Front/Rear: 250/290 kPa
Wheel dynamic balance requirement	< 0.022 lb
	< 10 g

Wheel alignment values (at curb weight)

Item	Parameter
Front camber (°)	-0.5±0.75
Front toe-in (°)	0.05±0.08(side)
Total front wheel toe-in (°)	0.1±0.16
Kingpin inclination angle (°)	8.63±0.75
Kingpin caster angle (°)	6.33±0.75
Rear camber (°)	-1±0.75
Rear wheel toe-in (°)	0.20±0.08(side)
Total rear wheel toe-in (°)	0.40±0.16

Seats:

Item	Parameter
Forward and backward moving spaces for front seats (seat cushion depth measured)	10 in (260 mm) forward from the end of slide rail travel
Seatback angle of front seats (cushion depth measured)	25°
Normal service conditions of front seatbacks	20° forward and 40° backward from the designated position; 7.9 in (200 mm) forward and 2.4 in (60 mm) backward from the slide rail; slide rail inclination: 4.5°
Forward and backward moving spaces for rear seats (seat cushion depth measured)	Not adjustable
Backrest angles of rear seats (seat cushion depth measured)	30°(sides)/27°(middle)
Normal service conditions of seatbacks	Design position (not adjustable)

Fluid

Item	Parameter	
Model	Rear drive extended range	AWD
Front drive gear transmission oil type	-	Castrol BOT-383
Front drive gear transmission oil amount	-	0.44±0.011 ukgal 2±0.05 L

Item	Parameter	
Rear drive gear transmission oil type	Castrol BOT-383	Castrol BOT-383
Rear drive gear oil amount	0.374±0.011 ukgal	0.374±0.011 ukgal
	1.5 L	1.5 L
Brake fluid type	HZY6/DOT4	HZY6/DOT4
Brake fluid amount	0.253±0.011 ukgal	0.253±0.011 ukgal
	1.15±0.05 L	1.15±0.05 L
Motor controller coolant type	Glycol organic acid long-acting anti-rust antifreeze (-40)	Glycol organic acid long-acting anti-rust antifreeze (-40)
Motor controller coolant amount	1.06±0.044 ukgal	1.17±0.044 ukgal
	4.8±0.2 L	5.3±0.2 L

Tips

Vehicle Identification

Vehicle Identification Number (VIN)

- ① VIN attached on the right of front bumper beam
- ② VIN attached under clamping ring of the bonnet inner panel
- ③ VIN attached on the front windscreen cross sill
- ④ VIN attached on the front side of the rear motor

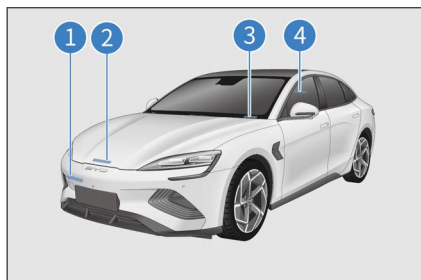

- ⑤ VIN attached on the lower corner of front left door
- ⑥ VIN attached on the left rear door sill
- ⑦ VIN attached on the left rear wheel hubcap metal

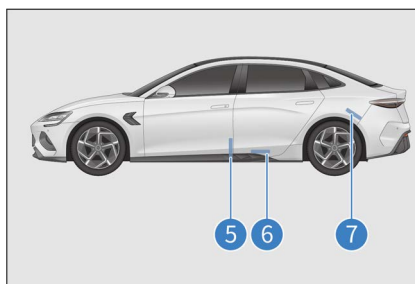

- ⑧ VIN attached inside the right of the boot



VIN is engraved on the lower beam of the front right seat.

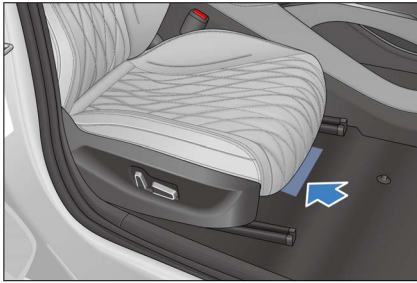

Note: After connecting the VDS, the VIN can be found in the upper right corner of the screen for the corresponding model. For details, please refer to the VDS operation manual.

Vehicle Nameplate

The vehicle nameplate is located at the lower sheet metal sink of the right B-pillar.

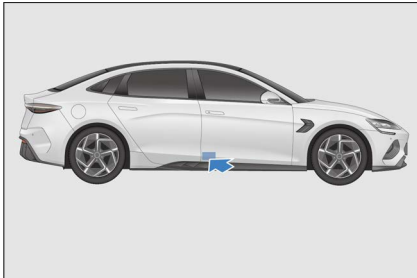

Model and Serial Number of Drive Motor

- ① The model and serial number of front drive motor are engraved on the front drive motor housing*.
- ② The model and serial number of rear drive motor are engraved on the rear drive motor housing.

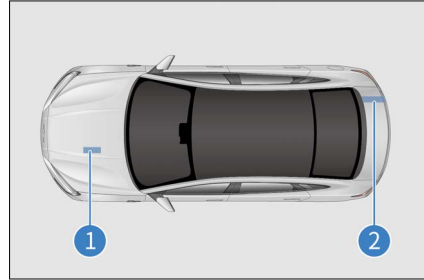

Warning Labels

- ① A/C system and cooling fan label
- ② Battery position label

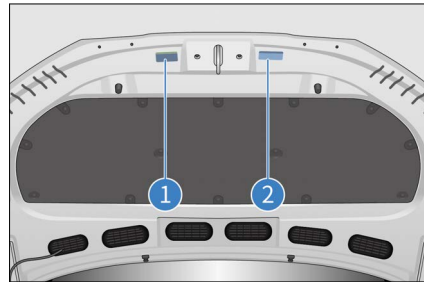

The side airbag warning labels are attached below the left and right B-pillar and C-pillar.



The airbag warning label is printed on the passenger's sun visor.

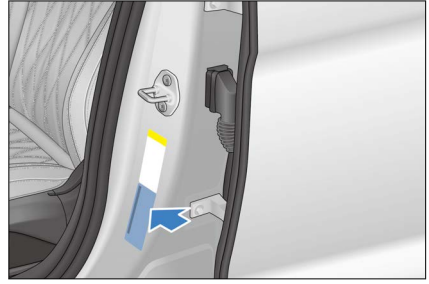

The DC charging warning label is attached on the inner side of the charge port door.

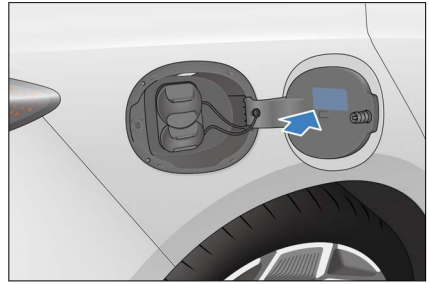
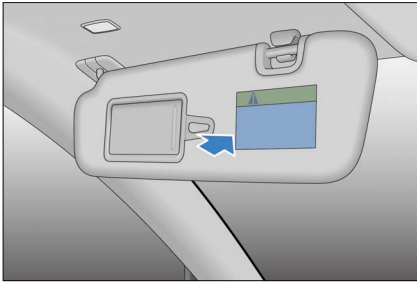

WARNING

- Do not use rear-facing children restraint device in front of the seats with active airbags protection.
- It may cause children death or severe injury.

The tyre pressure label is attached below the left B-pillar.

Transponder Mounting

The transponder mounting position is located in the upper right of the front windscreen.



 CAUTION

- Do not overlap with the glass frame or other objects when attaching the electronic logo.

Declarations of Conformity

Smart Key



Uzbekistan

Model: D1-92

This equipment is not entitled to protection against harmful interference and may not cause interference to duly authorised systems.



EU countries

Model: D1-92

This equipment is not entitled to protection against harmful interference and may not cause interference to duly authorised systems.



Brazil

Model: D1-92

This equipment is not entitled to protection against harmful interference and may not cause interference to duly authorised systems.



Japan

Model: D1-315

This equipment is not entitled to protection against harmful interference and may not cause interference to duly authorised systems.

MmWave Radars



EU countries

Certificate ID: T.2021.08.0001

This equipment is not entitled to protection against harmful interference and may not cause interference to duly authorised systems.



Japan

Certificate ID: 219-210015

This equipment is not entitled to protection against harmful interference and may not cause interference to duly authorised systems.



Brazil

Certificate ID: 15210-21-03745

This equipment is not entitled to protection against harmful interference and may not cause interference to duly authorised systems.

Radio Frequency



Your vehicle has different types of radio equipment. The manufacturers of the radio equipment declare the RF Modules listed above have been evaluated against the essential requirements and other relevant provisions of Directive 2014/53/EU. The full text of the EU declaration of conformity is available at the following Internet address: <https://cn-prod.byd.com/eu/eu-doc>.

Numerics

12V Auxiliary Power..... 162

A

A/C Buttons..... 151
A/C Operation Interface..... 151
A/C Settings..... 158
A/C System Maintenance..... 181
Acoustic Vehicle Alerting System (AVAS)..... 132
Adaptive Cruise Control (ACC)..... 111
Air Purification System..... 156
Airbags..... 15
Anti-lock Braking System (ABS)... 140
Anti-theft Alarm system..... 30
Automatic Anti-glare Interior Rearview Mirror*..... 144
Automatic Vehicle Hold (AVH)..... 108

B

Battery Leakage Rescue..... 193
Bill Box..... 161
Blind Spot Assist..... 127
Brake fluid..... 180
Break-in Period..... 96

C

Carrying Luggage..... 99
Charge Port Anti-theft Lock..... 90
Charging Safety Warnings..... 78
Check Before Charging..... 82
Child Presence Detection (CPD)... 143
Child Protection Lock..... 59
Coolant..... 179
Cubby Box..... 160

D

Data Collection and Processing..... 31

Discharging Device..... 89
Driver Attention Warning (DAW)... 142
Driver's Door Switches..... 71
Driving Precautions..... 109
Driving Safety Precautions..... 97
Driving Safety Systems..... 138

E

Electronic Parking Brake (EPB).... 106
Electronic Smart Key..... 48
Emergency Call (E-Call)..... 75
Emergency Lane Keeping Assist (ELKA)..... 126
Emergency Shutdown System.... 192
Emergency Vehicle Locking with Mechanical Key..... 57

F

Fire Prevention..... 101
Front Cross Traffic Alert (FCTA) & Front Cross Traffic Braking (FCTB).... 120
Front Seat Cup Holder..... 160
Function Definition..... 153
Fuses..... 184

G

Gear Shift Controls..... 105
Glove Box..... 159
Grab Handles..... 162

H

Hazard Warning Light Switch..... 75
Head-up Display (HUD)* 130
High Beam Assist..... 123
High-Voltage Battery..... 93

I

If a Tyre Goes Flat.....	195
If Smart Key Battery Is Exhausted	192
If the Vehicle Needs Towing.....	194
Indicators/Warning Lights.....	38
Installing Child Restraint Systems.	25
Intelligent Cruise Control.....	115
Intelligent Speed Limit Control....	122
Interior Cleaning.....	175
Interior Light Switch.....	76

L

LCD Instrument Cluster.....	36
Light Switches.....	67
Locking/Unlocking with Mechanical Key.....	50
Low-Voltage Battery.....	95

M

Maintenance Plan.....	168
Maintenance Schedule Requirements	168

O

Odometer Switch.....	73
Opening the Bonnet.....	179

P

Paint Maintenance Tips.....	173
Panoramic View System.....	133
Power Side Mirrors.....	145
Power-Assisted Steering Mode Settings.....	67
Predictive Emergency Braking (PEB) System.....	117

R

Regular Maintenance.....	172
Reservation Charging (Only AC).....	87

S

Saving Energy and Extending Vehicle Service Life.....	99
Seatback Pockets.....	161
Seats.....	60
Self-Maintenance.....	176
Smart Access and Start System.....	57
Snow Chain.....	103
Starting the Vehicle.....	104
Steering Wheel Switches.....	64
Storage Box on Interior Panel.....	161
Sun Visor.....	162

T

Traffic Sign Recognition (TSR).....	121
Trailer Towing.....	97
Transponder Mounting.....	207
Tyre Pressure Monitoring.....	131
Tyres.....	182

U

USB Charge Port.....	163
Using Seat Belts.....	12

V

Vehicle Cleaning.....	173
Vehicle Corrosion Prevention.....	172
Vehicle Fire Rescue.....	193
Vehicle Identification Number (VIN)	205
Vehicle Storage Precautions.....	178
Vehicle Use Suggestions.....	98
Vents.....	155

W

Wading into Water.....	100
Warning Labels.....	206
Washer.....	180
Winter Driving Precautions.....	110
Wiper Blades.....	181
Wiper Switch.....	70
Wipers.....	146
Wireless Phone Charger.....	163

Abbreviation List

Abbreviations

Terminology	Name	Terminology	Name
ECU	Electronic Control Unit	EPB	Electronic Parking Brake
ESC	Electronic Stability Controller	SOC	State of Charge
ACC	Adaptive Cruise Control	AEB	Automatic Emergency Braking
FCTB	Front Cross Traffic Braking	FCTA	Front Cross Traffic Alert
BSD	Blind Spot Detection	RCTA	Rear Cross Traffic Alert
RCTB	Rear Cross Traffic Braking	RCW	Rear Collision Warning
DOW	Door Open Warning	AVAS	Acoustic Vehicle Alert System
TCS	Traction Control System	VDC	Vehicle Dynamics Control
HHC	Hill Descent Control	HBA	Hydraulic Brake Assist
MAX	Maximum	MIN	Minimum

BUILD YOUR DREAMS

Edition date: 12.2023 EN_V1 (Right-hand Drive)